

Torque sensor Model 86403, -13, -23

©2010 burster
präzisionsmesstechnik gmbh & co kg
All rights reserved

Valid from: 2010-08-17

Manufacturer:
burster praezisionsmesstechnik gmbh & co kg
Talstrasse 1 – 5 P.O. Box 1432
76593 Gernsbach, 76587 Gernsbach,
Germany Germany

Tel.: (+49) 07224 / 6450
Fax.: (+49) 07224 / 64588
E-Mail: info@burster.com
www.burster.com

Note:

Exclusion of warranty liability for operating manuals

All information in the present documentation was prepared and compiled with great care and reproduced subject to effective control measures. No warranty is provided for freedom from errors. We reserve the right to make technical changes. The present information as well as the corresponding technical data can change without notice. Reproduction of any part of this documentation or its processing or revision using electronic systems is prohibited without the manufacturer's prior written approval.

Components, devices and measured value sensors made by burster praezisionsmesstechnik (hereinafter referred to as "product") are the results of targeted development and meticulous research. As of the date of delivery, burster provides a warranty for the proper condition and functioning of these products covering material and production defects for the period specified in the warranty document accompanying the product. However, burster excludes guarantee or warranty obligations as well as any liability beyond that for consequential damages caused by improper use of the product, in particular the implied warranty of success in the market as well as the suitability of the product for a particular purpose. Furthermore, burster assumes no liability for direct, indirect or incidental damages as well as consequential or other damages arising from the provision and use of the present documentation.

Präzisionsmessgeräte, Sensoren und Messsysteme
für elektrische, thermische und mechanische Größen



EG-Herstellererklärung

EC- Certificate of manufacture Conformity according to EN ISO/IEC 17050-1:2004

Name des Herstellers: burster präzisionsmesstechnik gmbh & co kg
Manufacturer's Name:

Adresse des Herstellers: Talstr. 1-5
Manufacturer's Address: 76593 Gernsbach, Germany

erklärt unter alleiniger Verantwortung, dass das gelieferte Produkt
declares under sole responsibility that the product as originally delivered

Produktname: Drehmoment-Sensor, rotierend
Product Name: Torque – sensor, rotating

Modellnummer(n) (Typ): 864xx
Models Number / Type:

Produktoptionen: Diese Erklärung beinhaltet obengenannte Produkte mit allen Optionen
Options *This declaration covers all options of the above product(s)*

mit den folgenden europäischen Richtlinien übereinstimmt und entsprechend das CE-Zeichen trägt:
complies with the requirements of the following applicable European Directives, and carries the CE marking accordingly:

| | |
|----------------------------------|---|
| 2006/95/EC <i>Low Voltage</i> | Elektrische Betriebsmittel zur Verwendung innerhalb bestimmter Spannungsgrenzen <i>Electrical Equipment designed for use within certain voltage limits</i> |
| 2004/108/EC <i>EMC</i> | Elektromagnetische Verträglichkeit <i>Electromagnetic Compatibility</i> |

Die oben beschriebenen Produkte sind konform mit den Anforderungen der folgenden Dokumente:
The objects of the declaration described above are in conformity with the requirements of the following documents:

EMV Anforderungen: EN 61326: 2006
EMC Requirements:

Diese Konformitätserklärung betrifft alle nach Ausstellungsdatum ausgelieferten Produkte:
This declaration of conformity applies to above-listed products placed on the EU market after:

| | | |
|-----------|---------------------|------------------------|
| Gernsbach | 24.06.2010 | i.V. Christian Karius |
| | <i>Datum / date</i> | <i>Quality Manager</i> |

Dieses Dokument ist entsprechend EN ISO/IEC 17050-1:2004 Abs. 6.1g ohne Unterschrift gültig / According EN ISO/IEC 17050 this document is valid without a signature.

Model 86403, -13, -23

Torque sensor





Model 86403



Model 86413



Model 86423



Warning!

The following instructions must be observed to prevent injuries:

- Observe all safety notices, instructions and regulations!
- Use the sensor with suitable safety devices only. These safety devices have to satisfy these requirements:
 - Protection from detaching parts
 - Protection from contusion and shear
 - Prevention from reaching rotating parts
 - Prevention from being tangled up and/or getting caught by parts
- During operation these safety devices have to stand still that means that they neither have to grind nor to rotate.
- Avoid any vibration. Vibrations, together with hand hold devices, cause injuries. On all devices they will cause damages.



Caution!

The following points must be observed to prevent injuries and damage to property:

- Avoid excessive torques, bending moments or axial forces.
- Make electrical connections to sensor during fitting. Check the measurement signal. It must stay within the permitted range.
- Support the sensor while it is being fitted.
- Avoid dropping the sensor.
- Pay attention to the permutation of drive side and measuring side. The friction of the slip rings will influence the measuring signal. At dynamic measurements, a restricted measurement accuracy has to be expected by the higher inert mass and the damping effect of the slip rings.
- Before installation, clean shafts and collars using a solvent such as acetone.
- There must be no foreign matter on shafts and collars when fitted.
- The hub must fit corresponding to the connection.
- Protect the sensor only at the threaded holes against rotation. Never use the cable for rotary protection.
- Do not use any pulse or impact wrenches. Both of them would destroy the sensor.
- When measuring dynamic torques, operating the sensor close to natural resonance will result in permanent damage.
- While cleaning, pay attention to the sensor's brushes. Avoid any bending.
- The warm-up period of the sensor takes 5 minutes.



Table of Content

| | |
|---|-----------|
| 1. Introduction | 11 |
| 1.1 Intended use..... | 11 |
| 1.2 Personnel | 11 |
| 1.3 Conversions and modifications..... | 11 |
| 1.4 Definition of terms..... | 11 |
| 2. Preparations for use | 13 |
| 2.1 Transport and unpacking..... | 13 |
| 2.2 Storage..... | 13 |
| 3. Principle of operation | 15 |
| 3.1 Mechanical structure..... | 15 |
| 3.2 Electrical Setup..... | 15 |
| 4. Installation | 17 |
| 4.1 Preparing the installation | 17 |
| 4.2 Mechanical installation..... | 18 |
| 4.2.1 Alignment..... | 18 |
| 4.2.2 Shaft connection | 18 |
| 4.2.3 Rotary Protection | 20 |
| 4.2.4 Installing safety devices | 20 |
| 4.2.5 Installation of cables | 21 |
| 4.3 Electrical Connections | 21 |
| 4.3.1 Shield..... | 21 |
| 4.3.2 Pin assignment | 21 |
| 4.3.3 Angle measurement excitation..... | 22 |
| 5. Calibration | 23 |
| 5.1 Manufacturer calibration | 23 |
| 5.2 DKD calibration..... | 23 |
| 5.3 Recalibration..... | 23 |



| | |
|---|-----------|
| 6. Measurement | 25 |
| 6.1 Switching on..... | 25 |
| 6.2 Optional: Calibration Control | 25 |
| 6.3 Static / Quasi-Static Torques..... | 26 |
| 6.4 Dynamic Torques | 26 |
| 6.5 Speed Limits..... | 27 |
| 6.6 Angle measurement (optional) | 27 |
| 6.7 Interferences | 27 |
| 7. Maintenance | 28 |
| 7.1 Maintenance Schedule | 28 |
| 7.2 Durability of the brushes..... | 28 |
| 7.3 Cleaning the Sensor | 29 |
| 7.4 Trouble Shooting | 31 |
| 8. Taking out of use | 32 |

1. Introduction

1.1 Intended use

The torque sensors are not safety components in the sense of the intended use.

- Only use the torque sensor for the measurement of torques.
This measured quantity is suitable for open-loop and closed-loop control functions.
- Always follow the applicable regulations and safety instructions.
- Transport and store the sensors correctly.
- The device must be fitted, commissioned, operated and removed properly.

1.2 Personnel

The installation, assembly, commissioning, operation and the disassembly must be carried out by qualified personnel only.

The personnel must have the knowledge and make use of the legal regulations and safety instructions.

1.3 Conversions and modifications

We will not accept liability for any change to the sensor without our written agreement.

1.4 Definition of terms

Measurement end:

The measurement end is the mechanical connection of the torque sensor in which the torque to be measured is induced.

This end normally has the smaller moment of inertia.

A pictogram identifies the measurement end of the sensor.



or



Drive end

The drive end is at the opposite end from the measurement end and is used as a mechanical connection of the torque sensor.

This end normally has the larger moment of inertia.

Unfixed end

The "unfixed end" refers to the shaft of the arrangement (drive, load). You must be able to move this shaft with a torque that is far lower than the rated torque of the sensor.

i.e.

$$M \ll M_{nenn}$$

The torque direction

A torque is designated a clockwise torque if the torque acts in a clockwise direction when looking towards the shaft end. In this case you obtain a positive electrical signal at the sensor output.

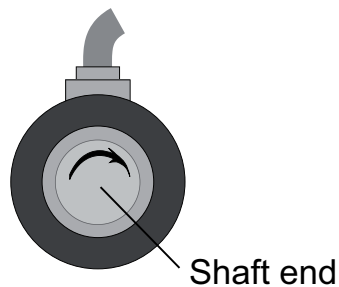

Figure 1: Torque, clockwise (looking towards the drive end)

You can use model 86403, 86413 and 86423 torque sensors to measure both clockwise and counterclockwise torques.

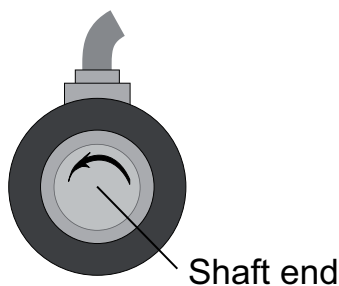

Figure 2: Torque, counterclockwise (looking towards the drive end)

2. Preparations for use

2.1 Transport and unpacking

- Only transport the sensors in their original packaging or in packaging of equivalent quality.
The sensor must not be able to move within the packaging.
- Protect the sensor from dampness.
- Inspect the sensor carefully for damage.

If you suspect that the unit has been damaged during shipping, notify the delivery company within 72 hours. Keep all packaging materials for inspection by the representative of the manufacturer or delivery company.

2.2 Storage

- Oil shafts and flanges lightly before storage.
- Pack the sensor in a clean piece of film.
- The sensor must only be stored in the following conditions:
 - dry
 - no condensation
 - temperature between 0 °C and 60 °C



3. Principle of operation

3.1 Mechanical structure

Basically the sensors of the models 86403, 86413 or 86423 consist of a torsional shaft applied with strain gauges as a full bridge. Therefore, this shaft is used as the measurement element of the sensor, which is supported by ball bearings.

For the signal transmission or for the supply of the strain gauge full bridge, a slip ring rotating transformer is arranged in the sensor. It consists of four slip rings on the shaft and fastened brushes at the stator. A connector or a cable connection is fixed at the housing.

Depending on the design the sensors have different connection possibilities, e.g. shafts, square, hexagonal etc.

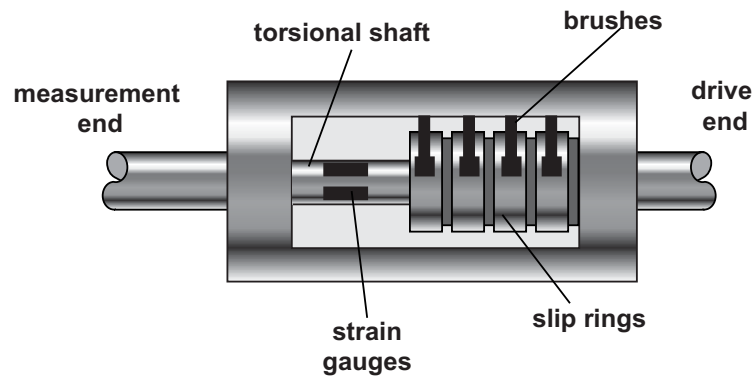

Figure 3: Mechanical structure of the sensor

3.2 Electrical Setup

The slip rings connect the strain gauge full bridge directly to the cable or to the plug

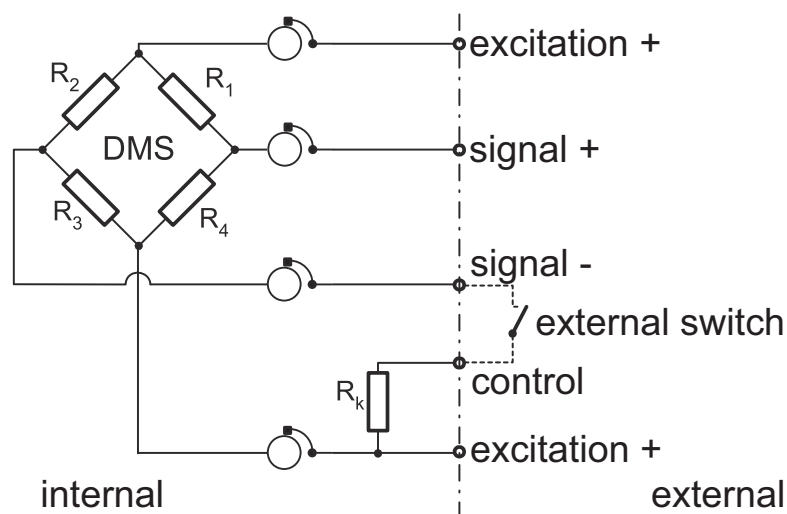

Figure 4: Principle sketch of a sensor with the optional calibration control



4. Installation

4.1 Preparing the installation

- Always use shielded cable with as low a capacitance as possible.

burster can supply cables that have been tested with our sensors and satisfy instrumentation requirements.

Relationship between sensitivity and cable length

Note:

With extension cables, the sensor sensitivity is affected by the cable length as a function of the bridge resistance and the conductor cross-section. Because of this, always order extension cables at the same time as the sensor. Get the sensor calibrated with the extension cables.

You must take into account both excitation conductors for the sensor when calculating the cable resistance.

i.e.

$$\text{cable resistance} = 2 \times \text{resistance of cable length}$$

burster präzisionsmesstechnik calibrates sensors in combination with the cable length ordered. In this case you do not need to take the cable length into account.

Difference per meter of cable length

| Conductor cross section | Cable resistance per m | for bridge resistance 350 Ω | for bridge resistance 700 Ω | for bridge resistance 1000 Ω |
|-------------------------|------------------------|-----------------------------|-----------------------------|------------------------------|
| 0.14 mm ² | 0.28 Ω | 0.08 % | 0.04 % | 0.028 % |
| 0.25 mm ² | 0.16 Ω | 0.046 % | 0.023 % | 0.016 % |
| 0.34 mm ² | 0.12 Ω | 0.034 % | 0.017 % | 0.012 % |

4.2 Mechanical installation



Caution!

Damage from excessive torques, bending moments or axial forces.
Support the sensor while it is being fitted!

Avoid dropping the sensor!

Make electrical connections to sensor during fitting. Check the measurement signal. It must stay within the permitted range.

4.2.1 Alignment

- Always consider drive end and measuring end!

One of these pictograms identifies the **measurement end** of the sensor:

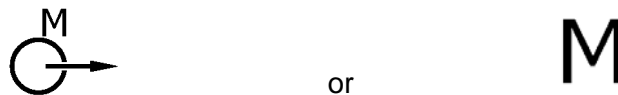

If you get the ends mixed up you must expect the following effects:

- The friction of the slip rings will influence the measurement signal.
- At dynamic measurements, a restricted measurement accuracy has to be expected by the higher inert mass and the damping effect of the slip rings.
- Before installation, align the shafts of the measurement arrangement.

This avoids any unnecessarily high reaction forces, while also reducing the load on the coupling and any spurious forces acting on the sensor.

It is often adequate to use a straight edge to align the arrangement in two mutually perpendicular planes.

- Adjust the cable connection upwards.

Doing this you will avoid abrasive dust from reaching into the brush connections.

4.2.2 Shaft connection

- Before installation, clean shafts and collars using a solvent such as acetone.

There must be no foreign matter on shafts and collars when fitted.

- The hub must fit corresponding to the connection.

Connections with a clamping piece

If you use a clamping piece, this clamping piece must be able to transfer the emerging torques safely.

Connection with a parallel key

- Secure the hub against slipping out.

Do this by safety screws on the feather key or by axial screws.

In general

Despite an accurate alignment, there will always be a small misalignment between the sensor's shaft and the environmental shafts.

- Therefore, always install the sensor between two half couplings (refer to Figure 5:).

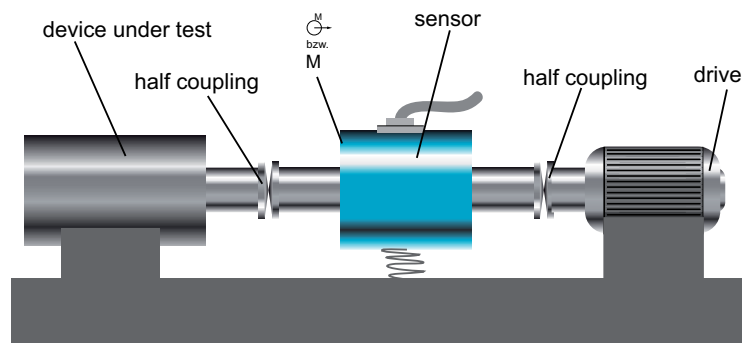

Figure 5: This is the only way to correct a radial misalignment using half couplings.

In this arrangement, the torque sensor and the two half couplings form a full coupling. This will give you the ability to correct this misalignment:

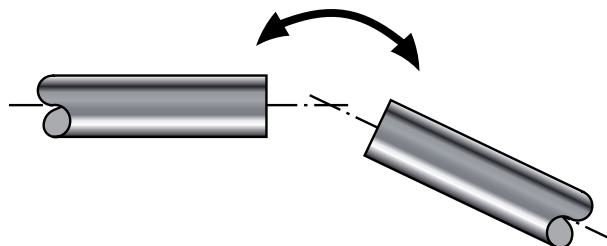

Figure 6: angular misalignment

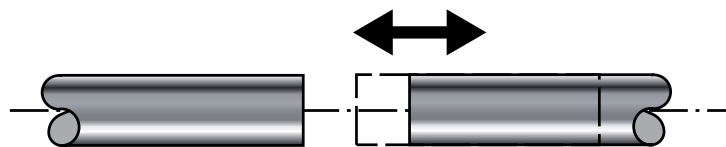

Figure 7: axial misalignment

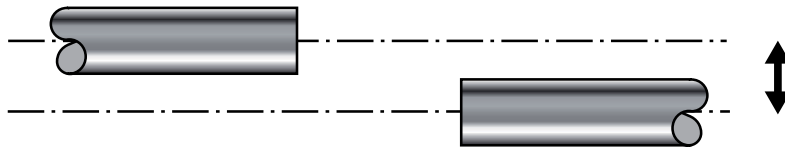

Figure 8: radial misalignment, this misalignment can only be corrected by the shown arrangement.

If not using couplings, very large lateral forces can affect the sensor. In addition, large forces occur on bearings, drive and devices under test, which limit their life span very strongly.

4.2.3 Rotary Protection



Caution!

Damages by wrong rotary protection!

Protect the sensor only at the threaded holes against rotation!

Never use the cable for rotary protection!

- Protect the sensor's housing against rotation.

Therefore, the sensor models 86403 und 86413 have threaded holes on their front or lateral surface.

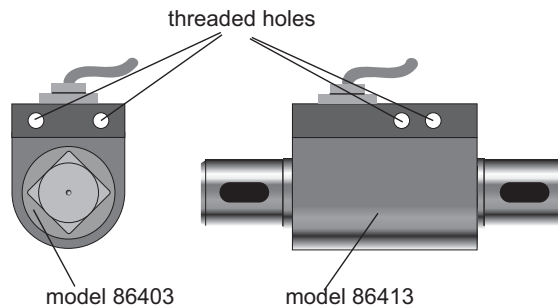

Figure 9: These threaded holes give you the ability to protect the sensor from rotation.

4.2.4 Installing safety devices

- Install suitable safety devices.

These safety devices have to satisfy the requirements below:

- Protection from detaching parts
- Protection from contusion and shear
- Prevention from reaching rotating parts
- Prevention from being tangled up and/or getting caught by parts

During operation these safety devices have to stand still that means that they neither have to grind nor to rotate.

4.2.5 Installation of cables

- Install the cable loosely and in shape of a gooseneck.

In this case the cable can follow the movement of the sensor and it can compensate this movements.

- Locate the sensor, the cable and the measuring instrument outside the fields of high-energy equipment.

This includes transformers, motors, contactors, frequency converters and so forth. Otherwise the electromagnetic fields from such equipment will act with their full effect on the measuring chain, causing incorrect measurements.

- Lay the measuring lines separately from high-power cables.

If the measuring lines are laid parallel to such cables, interference will be coupled in inductively and capacitatively.

In some cases it will be helpful to place an extra shield as additional protection over the measuring cable, or to lay it in a metal tube or pipe.

4.3 Electrical Connections

4.3.1 Shield

In combination with the sensor and the external electronics, the shield forms a Faraday Cage. By this, electro-magnetic disturbances do not have any influence on the measurement signal. At potential difference problems we recommend to ground the sensor.

4.3.2 Pin assignment

6 Pin Connector

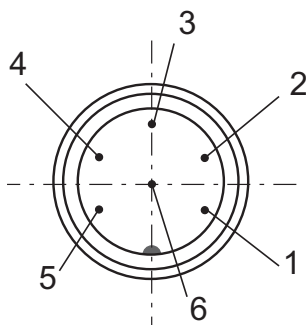

| 6 Pin Connector | Function |
|-----------------|------------------------------|
| 1 | Sensor excitation (-) |
| 2 | Sensor extation (+) |
| 3 | Shield |
| 4 | Sensor signal (+) |
| 5 | Sensor signal (-) |
| 6 | Calibration Control (option) |

Figure 10: View from soldering side

12 pin Connector (option angle measurement)

Note:

Only with optional angle measurement!

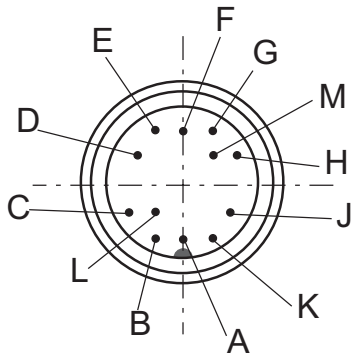

Figure 11: View from soldering side

| 12 pin Connector | Function |
|------------------|----------------------------------|
| A | Strain Gauge excitation (-) |
| B | Strain Gauge excitation (+) |
| C | Strain Gauge signal (+) |
| D | Strain Gauge signal (-) |
| E | Angle measurement excitation (-) |
| F | Angle measurement excitation (+) |
| G | Angle A (TTL) |
| H | Angle B (TTL) |
| J | Angle - |
| K | Calibration Control (option) |
| L | - |
| M | Shield |

4.3.3 Angle measurement excitation

Note:

Only with optional angle measurement!

| | |
|-------------------------------|-----------------|
| Stabilized excitation voltage | 5 V \pm 25 mV |
| maximum current | 20 mA |

5. Calibration

The torque sensors from burster präzisionmesstechnik are already traceably adjusted and tested in the factory. As an option we offer manufacturer calibration of the sensor.

5.1 Manufacturer calibration

The manufacturer calibration involves checking sensor data against traceably calibrated measuring instruments. A range of measurement points are taken in this calibration.

Manufacturer calibration produces a calibration report

5.2 DKD calibration

DKD calibration involves calibrating the sensor in accordance with DKD directives in a calibration laboratory monitored by the DKD. With this calibration we define the measurement uncertainty of the sensor.

Please contact us for further information.

5.3 Recalibration

- Recalibrate the sensor after 26 months at the latest.

Shorter intervals are recommended in the following cases:

- sensor overload
- after repair
- after improper use of the sensor
- when required by quality standards
- where there is a specific traceability requirement



6. Measurement



Warning!

Risk of injury!

Use the sensor with suitable safety devices only

These safety devices have to satisfy these requirements:

Protection from detaching parts

Protection from contusion and shear

Prevention from reaching rotating parts

Prevention from being tangled up and/or getting caught by parts

During operation these safety devices have to stand still that means that they neither have to grind nor to rotate.

6.1 Switching on

- Let the sensor warm up for about 5 minutes.

6.2 Optional: Calibration Control

If your sensor has this option, you are able to check your sensor by pushing a button.

Note:

Use calibration control at unloaded torque sensor, only!

To check the sensor:

- Release any load from the sensor.

During calibration, any load to the sensor control causes a wrong result.

- Close the control switch.

After the switch is closed, the sensor generates a signal equal to its rated value.

Advantage:

You may check the zero point and the nominal value before each measurement.

Function:

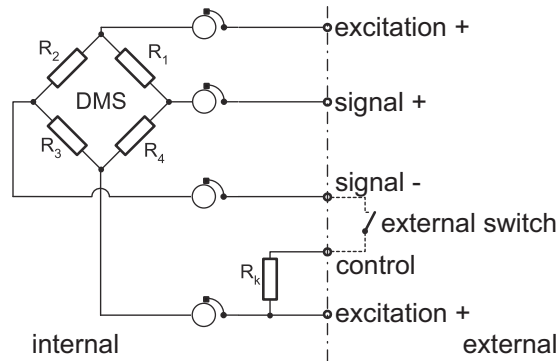

By applying negative Strain Gauge excitation, the measuring bridge is electrically detuned, so that at the output a measuring signal of 100% of the nominal value is available.

Optionally 50 % and 80 % are possible.

6.3 Static / Quasi-Static Torques

Static and/or quasi-static torque is a slowly changing torque. The applied torque may accept any value up to the nominal torque.

6.4 Dynamic Torques



Caution!

Operating the setup close to the natural resonance results in permanent damage.

The frequency of torques must lie below the natural frequency of the mechanical test setup.

Limit the peak-to-peak torque variation to 70 % of the rated torque.

Estimate of the mechanical natural frequencies:

$$f_0 = \frac{1}{2 \cdot \pi} \cdot \sqrt{c \left(\frac{1}{J_1} + \frac{1}{J_2} \right)}$$

| | |
|---------|--|
| f_0 : | Natural Frequency in Hz |
| J_1 : | Moment of Inertia 1 in kg*m ² |
| J_2 : | Moment of Inertia 2 in kg*m ² |
| c : | Torsional Rigidity in Nm/rad |

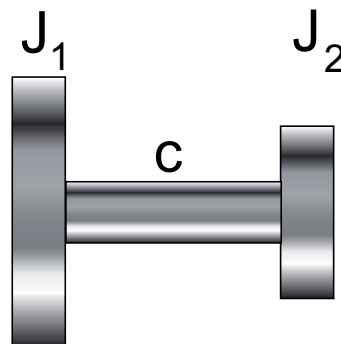

Further methods for the calculation of natural resonances are corresponding purchasable programs or books, e.g. Holzer-Procedure.

6.5 Speed Limits



Caution!

Damages caused by high rotation speed!

Only use the sensor for speeds below of the stated speed limit. Refer to data sheet

6.6 Angle measurement (optional)

Note:

Only with optional angle measurement!

At angle or speed measurement, the pulses per revolutions are acquired. By a second transmitter trace, displaced by 90° and flank evaluation, the pulses per revolutions can be quadrupled. The trace, displaced by 90°, can also be used for the rotational direction detection.

See corresponding data sheet for the output levels.

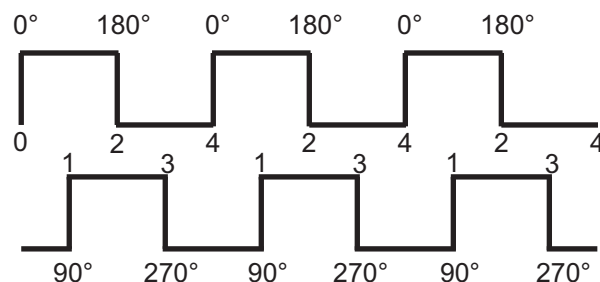

Figure 12: Impulse evaluation with a second impulse track

6.7 Interferences

By disturbances, measured value falsifications can occur by

- Vibrations
 - Temperature gradients
 - Temperature changes
 - Arising disturbance variables during operation, e.g. imbalance
 - Electrical disturbances
 - Magnetic disturbances
 - EMC (electromagnetic disturbances)
- Therefore avoid these disturbance variables by decoupling of vibrations, covers, etc.

7. Maintenance

7.1 Maintenance Schedule

| Action | Frequency | Date | Date | Date |
|---------------------------------------|-------------|------|------|------|
| Control of cables and connectors | 1x p.a. | | | |
| Calibration | < 26 months | | | |
| Control of fixation (flanges, shafts) | 1x p.a. | | | |

7.2 Durability of the brushes

The durability of the brushes is limited; it is depending on speed, number of revolutions and construction size.

In the table below, you will find the calculated durability of your sensor brushes in revolutions:

| Speed (1/min) | Small Size <35 mm width (revolutions) | Medium Size <45 mm width (revolutions) | Large Size <60 mm width (revolutions) | Extra Large Size <120 mm width (revolutions) |
|---------------|---------------------------------------|--|---------------------------------------|--|
| 10 | 5×10^7 | 4×10^7 | 3×10^7 | $1,5 \times 10^7$ |
| 100 | 2×10^7 | 9×10^6 | 8×10^6 | 4×10^6 |
| 500 | 7×10^6 | 5×10^6 | 3×10^6 | $1,5 \times 10^6$ |
| 1000 | 5×10^6 | 3×10^6 | 2×10^6 | - |
| 1500 | 4×10^6 | $2,4 \times 10^6$ | - | - |
| 2000 | 3×10^6 | - | - | - |

Our recommendation:

We recommend renewing the brushes at burster präzisionsmesstechnik according to the table above. During this procedure the slip rings will be tested and the sensor will be re-calibrated.

7.3 Cleaning the Sensor

In order to avoid measuring signal fluctuations, remove the carbon dust from the sensor housing (depending on speed). Clean the sensor as described below, five times during the durability of the brushes and allow us to check the slip rings.



Caution!

Brushes will be bended!

The brushes are extremely sensitive to bending.

Take suitable care, while cleaning.

Cleaning procedure:

- Remove the sensor.
- Release the four screws at the top of the sensor.

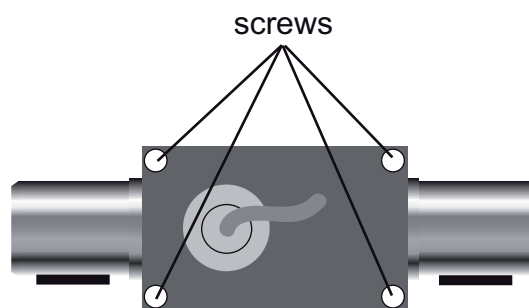

Figure 13: Four screws are located at the sensor's cap

- **Carefully** open the sensor cap with the brushes.

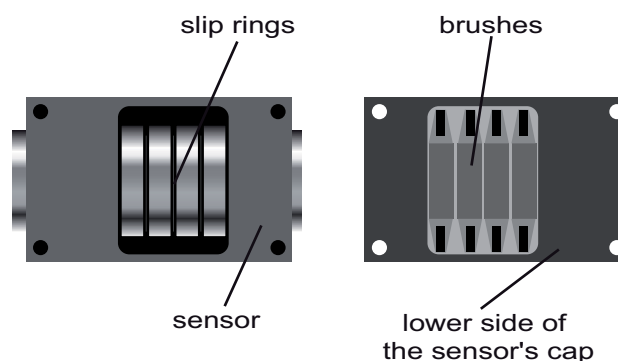

Figure 14: The opened sensor

- **Carefully** remove the carbon dust from the sensor.

Do this by using a fine and long hair brush and dry and oil-free air.

- Afterwards clean the slip rings

Do this by using a fine cloth or a Q-tip, slightly moistened with spirit.

- Now, carefully clean brush-unit.

Use a brush as well and if necessary blow off dust by using dry and oil-free air.

- Re-assemble the sensor.

- Tighten the four screws at the sensor cap.

- Check the functionality of the sensor, after the reassembly.

Doing this, you have finished the sensor cleaning.

7.4 Trouble Shooting

In this table you may find the most frequent errors and their elimination.

| Error | Possible cause | Elimination |
|---------------------------------|--|-----------------------------------|
| no signal | no sensor excitation | connect excitation |
| | Outside of permissible range | check excitation |
| | no mains excitation | connect excitation |
| | cable defect | repair cable |
| | wrong connected signal output | connect output correctly |
| | evaluation electronics defect | repair / change |
| sensor does not react to torque | shaft is not clamped | clamp correctly |
| | no sensor excitation | connect excitation |
| | no mains excitation | connect excitation |
| | outside of permissible range | check excitation |
| | cable defect | repair cable |
| | wrong connected connector | connect output correctly |
| Signal has dropouts | Carbon dust in the sensor | clean sensor |
| | Axial position of rotor to stator outside of tolerance | send to manufacturer |
| | cable defect | repair cable |
| Zero point outside of tolerance | strong lateral forces | reduce lateral forces |
| | shaft mounted distorted | Mount correctly |
| | distorted shaft string | Release from desertion |
| | cable defect | repair cable |
| | distorted flanges | check evenness of flange surfaces |
| | shaft overloaded | send sensor to manufacturer |
| Wrong torque indication | calibration is not correct | re-calibrate |
| | sensor is defect | send to manufacturer |
| | torque shunt | eliminate shunt |
| Shaft drags | shaft drags in stator | align shaft |
| | strong lateral forces | reduce lateral forces |
| Vibrations | alignment of shaft is not correct | Align correctly |
| | unbalance | balance the corresponding parts |

8. Taking out of use



Caution!

**Damage from excessive torques, bending moments or axial forces.
Support the sensor while it is being unfitted!**

Avoid dropping the sensor!

Make electrical connections to sensor during fitting. Check the measurement signal. It must stay within the permitted range.

- Remove the sensor professionally.
- Pay attention to coupling's function.
- Protect the sensor from strikes to the sensor housing.
- Protect the sensor from bending moments e.g. from levers.
- Support the sensor.
- Protect the sensor from falling down.