

# Accessories for Precision Torque Sensor

## Model 8661



- Mounting block

### Installation note

If the sensor is removed and refitted quite often it is recommendable to mount it permanently.

The mounting block has a central hole and special design allowing a range of options for reliable cable attachment. Two clips ensure the sensor is fixed securely. For measuring ranges < 100 Nm (because of the load from its own weight) and at higher speeds of 10,000 rpm and above (because of resistance effects), the sensor housing should be mounted on the existing mechanical structure.

A mounting block is provided for this purpose.

### Mounting block Model 8661-Z00X

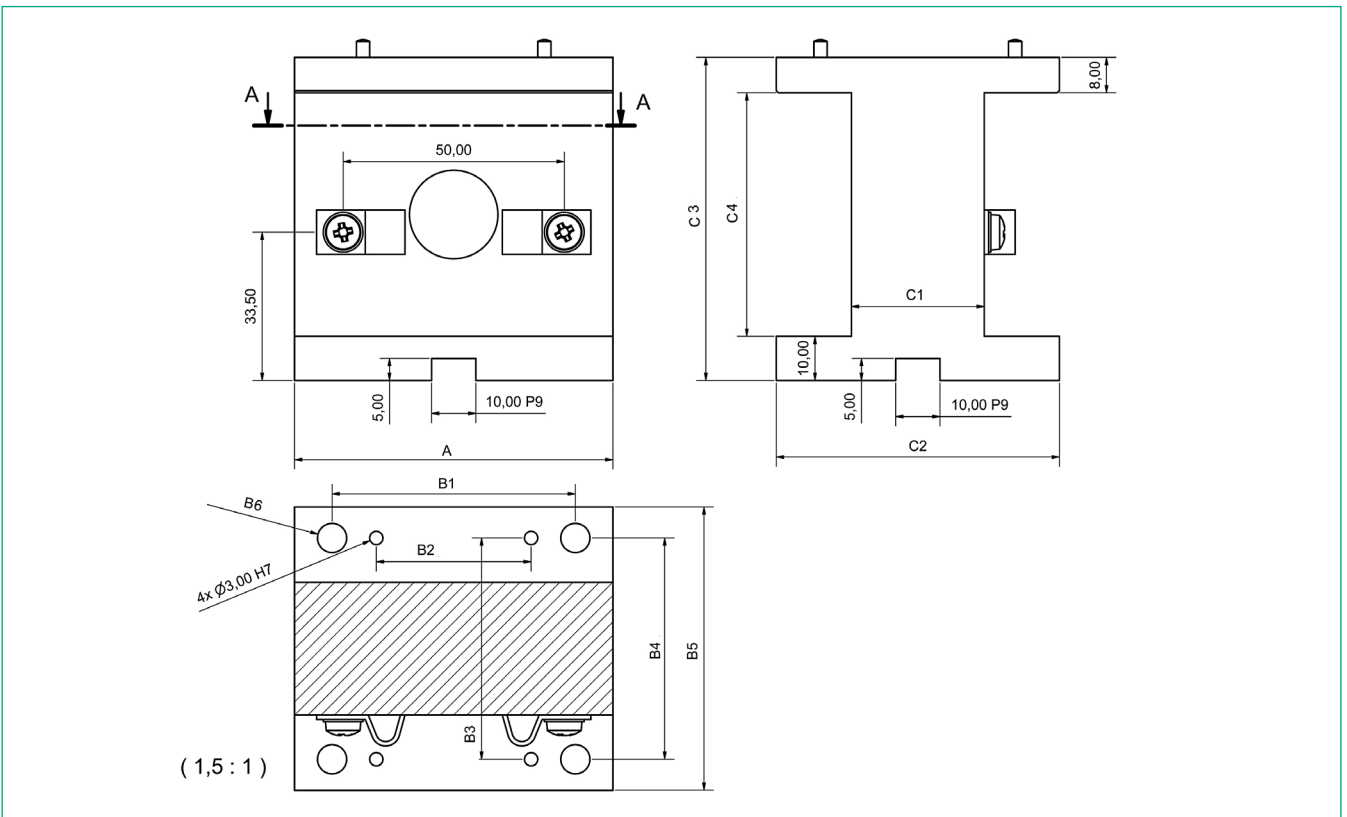

Model	Measuring Range [Nm]	A	B1	B2	B3	B4	B5	B6	C1	C2	C3	C4
8661-Z001	0.05; 0.1; 0.2; 0.5; 1; 2	64.5	50	35	30	30	40	4 x 5.50	20	40	65	47