

OPERATION MANUAL

Precision torque sensor Model 8630

© 2023 burster
präzisionsmesstechnik gmbh & co kg
All rights reserved

Manufacturer:
burster
präzisionsmesstechnik gmbh & co kg
Talstrasse 1 - 5 Postfach 1432
76593 Gernsbach 76593 Gernsbach
Germany Germany

Valid from: June 13, 2023

Tel.: +49 7224 645-0
Fax: +49 7224 645-88
Email: info@burster.de
www.burster.de

4401-BA8630EN-5999-061529

Warranty disclaimer

All information in the present documentation was prepared and compiled with great care and reproduced in accordance with effective control measures. This documentation may contain errors, and the information it contains and the corresponding technical data are subject to change without notice. Reproduction of any part of this documentation or its processing or revision using electronic systems is prohibited without the manufacturer's prior written approval.

Components, devices and measurement sensors made by burster präzisionsmesstechnik (hereinafter referred to as the "product") are the result of targeted development and meticulous research. From the date of delivery, burster provides a warranty for the proper condition and functioning of these products covering material and production defects for the period specified in the warranty document accompanying the product. However, burster waives any guarantee or warranty obligations or any additional liability for consequential damages caused by improper use of the product, in particular the implied guarantee of success in the market as well as the suitability of the product for a particular purpose. Furthermore, burster assumes no liability for direct, indirect or incidental damages or for consequential or other damages arising from the provision and use of the present documentation.

Trademark information

Intel Pentium® is a registered trademark of Intel Corporation. Windows®, Excel® are registered trademarks or trademarks of Microsoft Corporation in the United States and/or other countries. All brand or product names mentioned in this document are trademarks or registered trademarks of their respective trademark owners. By mentioning these trademarks, burster präzisionsmesstechnik gmbh & co kg is not laying claim to trademarks other than its own.

EU-Konformitätserklärung (nach EN ISO/IEC 17050-1:2010) EU-Declaration of conformity (in accordance with EN ISO/IEC 17050-1:2010)

Name des Ausstellers: burster präzisionsmesstechnik gmbh & co kg
Issuer's name:

Anschrift des Ausstellers: Talstr. 1-5
Issuer's address: 76593 Gernsbach, Germany

Gegenstand der Erklärung: Präzisions-Drehmomentsensor
Object of the declaration: Precision Torque Sensor

Modellnummer(n) (Typ): 8625 / 8630 / 8631
Model number / type:

Diese Erklärung beinhaltet obengenannte Produkte mit allen Optionen
This declaration covers all options of the above product(s)

Das oben beschriebene Produkt ist konform mit den Anforderungen der folgenden Dokumente:
The object of the declaration described above is in conformity with the requirements of the following documents:

Dokument-Nr. <i>Documents No.</i>	Titel <i>Title</i>	Ausgabe <i>Edition</i>
2011/65/EU + delegD (EU) 2015/863	Richtlinie zur Beschränkung der Verwendung bestimmter gefährlicher Stoffe in Elektro- und Elektronikgeräten <i>Directive on the restriction of the use of certain hazardous substances in electrical and electronic equipment</i>	2011 + 2015
2014/30/EU	Richtlinie zur Harmonisierung der Rechtsvorschriften der Mitgliedsstaaten über die Elektromagnetische Verträglichkeit <i>Directive on the harmonization of the laws of the Member States relating to electromagnetic compatibility</i>	2014
EN 61326-1	Elektrische Mess-, Steuer-, Regel- und Laborgeräte – EMV-Anforderungen – Teil 1: Allgemeine Anforderungen <i>Electrical equipment for measurement, control and laboratory use – EMC requirements – Part 1: General requirements</i>	2013
EN 61326-2-3	Elektrische Mess-, Steuer-, Regel- und Laborgeräte – EMV-Anforderungen – Teil 2-3: Besondere Anforderungen <i>Electrical equipment for measurement, control and laboratory use – EMC requirements – Part 2-3: Particular requirements</i>	2006

Gernsbach
Ort / place

02.04.2020
Datum / date

ppa. Christian Karius
Quality Manager

Dieses Dokument ist entsprechend EN ISO/IEC 17050-1:2010 Abs. 6.1g ohne Unterschrift gültig /
According EN ISO/IEC 17050 this document is valid without a signature.

Contents

1. For your safety	6
1.1 Symbols used in the operation manual	6
1.1.1 Signal words.....	6
1.1.2 Pictograms	6
1.2 General safety instructions	7
2. Introduction	8
2.1 Intended use	8
2.2 Customer service	8
2.2.1 Customer service department.....	8
2.2.2 Contact person.....	8
2.3 Ambient conditions	9
2.3.1 Storage.....	9
2.3.2 Cleaning	9
2.4 Personnel.....	9
2.5 Contents of pack.....	10
2.6 Unpacking.....	10
2.7 Warranty	10
2.8 Modifications and maintenance	11
3. Device design and general information	12
3.1 Definitions	12
3.2 Mechanical design	13
3.3 Electrical design.....	13
3.3.1 8630 torque sensor with bridge output	14
3.3.2 8630 torque sensor with amplifier	15
3.4 Static and quasi-static torques.....	16
3.5 Dynamic torques	17
3.6 Interference.....	17
3.7 Troubleshooting table	18
4. Installation	19
4.1 Mechanical installation.....	19
4.1.1 Preparing for alignment and fitting	20
4.1.2 Installation options	21
4.2 Electrical connection	24
4.2.1 Power supply.....	24
4.2.2 Pin-out of the electrical socket.....	25
4.2.3 Pin-out of the USB connector	25
4.2.4 Power supply for the 8630 torque sensor fitted with USB	26
4.2.5 Power supply for the 8630 torque sensor with built-in electronics via the circular connector	26
4.2.6 Power supply for the 8630 torque sensor without built-in electronics.....	27
4.2.7 Cable.....	27
4.2.8 Connecting the shield	27

Torque Sensor 8630

4.2.9	Running cables	28
4.3	Measurement operation.....	29
4.3.1	Switching on.....	29
4.3.2	The torque direction	29
4.3.3	Check function (for 8630 with instrumentation amplifier)	30
4.3.4	Dual-range sensor	30
5.	Calibration and adjustment.....	31
5.1	Factory calibration	31
5.2	Calibration certificate with accreditation symbol.....	31
5.3	Recalibration.....	31
6.	Taking out of use.....	32
7.	Technical data	33
7.1	Electromagnetic compatibility	33
8.	Accessories available	33
9.	Disposal.....	34



1. For your safety

The following symbols are used in this operation manual to warn of hazards.

1.1 Symbols used in the operation manual

1.1.1 Signal words



The following signal words are used in the operation manual according to the specified hazard classification.

 <b style="font-size: 1.5em;">DANGER
<p>High degree of risk: indicates a hazardous situation which, if not avoided, will result in death or serious injury.</p>
 <b style="font-size: 1.5em;">WARNING
<p>Moderate degree of risk: indicates a hazardous situation which, if not avoided, may result in death or serious injury.</p>
 <b style="font-size: 1.5em;">CAUTION
<p>Low degree of risk: indicates a hazardous situation which, if not avoided, could result in minor or moderate injury.</p>
<b style="font-size: 1.5em;">NOTICE
<p>Property damage to the equipment or the surroundings will result if the hazard is not avoided.</p>

Note: It is important to heed these safety notices in order to ensure you handle the model 8630 torque sensor correctly.

IMPORTANT: Follow the information given in the operating manual.



1.1.2 Pictograms

	<p>Electric shock hazard.</p>
	<p>Observe the advice for protecting the model 8630 torque sensor.</p>

Torque Sensor 8630

1.2 General safety instructions

The model 8630 torque sensor is state of the art, and is safe to operate. However, if the 8630 torque sensor is not used or operated as intended, it may present a hazard.

	 DANGER
	<p>Electric shock hazard! The following instructions must be followed to prevent electric shock and injuries:</p> <ul style="list-style-type: none"> • In order to achieve high measuring sensitivity, the model 8630 torque sensor was not designed with the usual safety factors (2 ... 20) for machine designs. For applicable overload factors, see the data sheet. • Observe accident prevention regulations, including for accessories used. • Use the model 8630 torque sensor only in non-safety-critical applications. • The 8630 torque sensor must not be used for medical purposes. • Only use the model 8630 torque sensor outside of potentially explosive areas (Ex protected areas).

	NOTICE
	<p>The following points must be observed to prevent injuries and damage to property:</p> <ul style="list-style-type: none"> • The limits for permissible mechanical, thermal and electrical loads are shown in the data sheet. These limits must not be exceeded. Take these limits into account when planning the measuring arrangement, and during installation (preferably with the display for the torque connected) and operation. • Impacts and shocks may damage the model 8630 torque sensor (e.g. if it is dropped). Exercise due care when handling and fitting the 8630 torque sensor. • Torque peaks in excess of the permissible overload may destroy the torsion shaft. Make sure that such peaks do not occur, or ensure that they are absorbed. • Avoid excessive torques, bending moments or axial loads. • Support the model 8630 torque sensor while it is being fitted. • When measuring dynamic torques, operating the 8630 torque sensor close to its natural resonance will result in permanent damage. The frequency of dynamic torques must lie below the resonant frequency of the mechanical structure. • Limit the peak-to-peak variation of dynamic torques to 70 % of the rated torque.

2. Introduction

IMPORTANT: Read the operation manual carefully before using the equipment, and keep it for future reference.

2.1 Intended use

The model 8630 torque sensor measures static and dynamic torques. This measured quantity is suitable for open-loop and closed-loop control functions. The respective upper range value is shown on the type plate.

Both the low mass of the model 8630 torque sensor and its high torsional rigidity are an advantage when measuring dynamic torques. However, you need to pay attention to the spring constant and the cut-off frequency of the model 8630 torque sensor with such measurements. You can find both of these in the data sheet. For more information on estimating the resonant frequency and measuring dynamic torques, see section 3.5 Dynamic torques on page 17.

The model 8630 torque sensor is maintenance-free. The electrical measurement signals can be transmitted to a remote higher-level electronic system, where they can be displayed, recorded, processed and used for control and regulation tasks.

Use the model 8630 torque sensor only for measuring torque.

Do not use the 8630 torque sensor in safety-critical applications or for medical purposes.

The model 8630 torque sensor is **not intended for use as a safety device**.

2.2 Customer service

2.2.1 Customer service department

For repair inquiries, please call our customer service department on +49 7224 645-53.

Please have the serial number to hand. The serial number is the only way to clearly identify the technical version of the instrument so that we can provide help quickly. You will find the serial number on the type plate of the model 8630 torque sensor.

2.2.2 Contact person

If you have any questions relating to the model 8630 torque sensor, please contact your representative or go directly to burster präzisionsmesstechnik gmbh & co. kg.

Head office

burster präzisionsmesstechnik
gmbh & co kg
Talstrasse 1 - 5
76593 Gernsbach
Germany

Phone: +49 7224 645-0
Fax: +49 7224 645-88
Email: info@burster.de

Torque Sensor 8630

2.3 Ambient conditions

- Avoid radiant heat or cooling from one side.
- Protect the 8630 torque sensor from moisture.
- The 8630 torque sensor is **not** resistant to chemical agents. **Do not** use the sensor in a corrosive environment.
- Keep the bearings and connectors free of dust, dirt and other foreign matter.

2.3.1 Storage

Use clean packaging to package the model 8630 torque sensor. The 8630 torque sensor must be stored under the following conditions:

- Dry atmosphere
- No condensation
- No dust
- Temperature between 0 °C and 60 °C.

2.3.2 Cleaning

	NOTICE
	<p>Do not immerse the 8630 torque sensor in water or hold it under running water. Do not use strong cleaning agents as these may damage the 8630 torque sensor. Clean the model 8630 torque sensor using a dry cloth.</p> <p>Ensure that the shaft and mating parts are completely clean and have no traces of lubricants at the time of fitting. Use a solvent such as acetone to clean the shafts before fitting. Make sure there is no foreign matter on the shafts at fitting.</p>

2.4 Personnel

Personnel must be familiar with the relevant regulations. They must follow these regulations. Only trained personnel who are familiar with the applicable safety regulations are permitted to operate the model 8630 torque sensor.

2.5 Contents of pack

- Torque sensor model 8630
- Mating connector
- Digital operation manual on our website (www.burster.com)
- Digital data sheet on our website (www.burster.com)
- Optional: USB cable
- Optional: Fitted flange or supplied with bracket

2.6 Unpacking

	<h3>NOTICE</h3>
<p>Never connect up the 8630 torque sensor if the sensor shows signs of damage incurred in transit. Only ever use the 8630 torque sensor under the conditions specified in this operation manual.</p>	

Inspect the model 8630 torque sensor for damage. If you suspect that the unit has been damaged during shipping, notify the delivery company within 72 hours.

The packaging should be retained by a representative of the manufacturer and/or the delivery company.

The model 8630 torque sensor should be shipped only in its original packaging or in packaging capable of providing an equivalent degree of protection. The model 8630 torque sensor must be held securely (immovable) in its packaging.

2.7 Warranty

burster präzisionsmesstechnik gmbh & co kg provides a manufacturer's warranty for a period of 24 months after delivery.

Any repairs required during this time will be made without charge. This does not include damage arising from improper use.

Please note the following when sending the model 8630 torque sensor in for repair:

- If there is a problem with the sensor, please describe the fault in as much detail as possible.
- Technical specifications subject to change at any time without notice. We also state explicitly that we do not accept liability for consequential damage.
- The instrument must always be dispatched in suitable packaging.

Torque Sensor 8630

2.8 Modifications and maintenance

Note: The warranty shall be deemed void **immediately** if you open or dismantle the model 8630 torque sensor during the warranty period.

The model 8630 torque sensor does not contain any parts that are intended to be serviced by the user. Only the manufacturer's own qualified personnel are permitted to open the model 8630 torque sensor.

It is not permitted to make any changes to the model 8630 torque sensor without the written agreement of burster präzisionsmesstechnik gmbh & co kg. burster präzisionsmesstechnik gmbh & co kg does not accept liability for damages or injury if this condition is disregarded.

Our recommendations

- Check cables and connectors annually.
- It is up to you as the user to determine the recalibration interval. We recommend that you check the 8630 torque sensor after no longer than 12 months. You can find further information in section 5 Calibration and adjustment on page 31.

Maintenance schedule

Action	Frequency	Date	Date	Date
Check cable and connector	1x annually			
Calibration	< 26 months			
Check the attachment (flanges and shafts)	1x annually			
Check the sensor	< 12 months			

3. Device design and general information

The figures given for the full dimensions, mass and power depend on the version of the 8630 torque sensor. Please refer to the data sheet for specific figures.

3.1 Definitions

Test side

The test side is the mechanical connection of the model 8630 torque sensor in which the torque to be measured is induced.

This side normally has the smaller moment of inertia.

On the model 8630 torque sensor, the test side is marked "TEST SIDE" on the shaft hub.

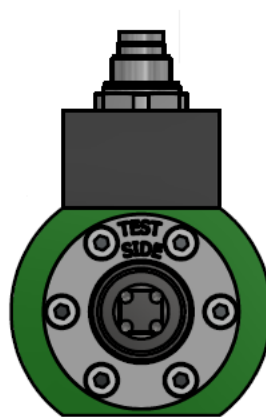

Figure 1: Test side, model 8630 torque sensor

Drive side

The drive side is the opposite side to the test side. The model 8630 torque sensor is also mechanically connected on this side.

Torque Sensor 8630

3.2 Mechanical design

The 8630 torque sensor does not contain any rotating parts. The shaft is joined directly to the housing on the drive side. Strain gages are mounted on the shaft, which acts as the torsion bar in the 8630 torque sensor. The torque is applied to the shaft end labeled “TEST SIDE”. The housing provides protection for the sensitive electronic instrumentation and contains the cable/plug connection. The housing is also used as the means of attaching the 8630 torque sensor.

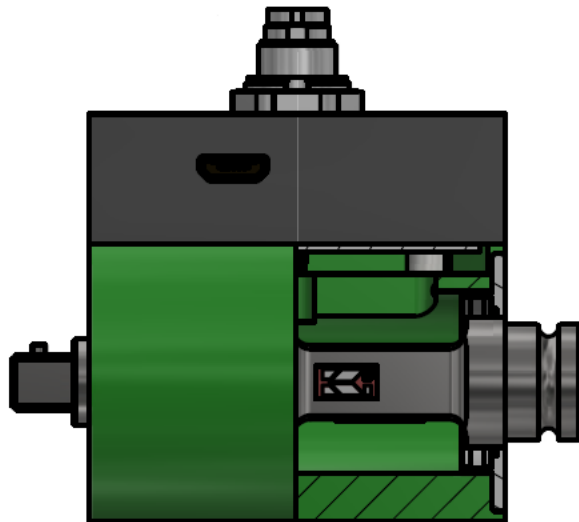



Figure 2: Basic design of the 8630 torque sensor

3.3 Electrical design

	<div style="background-color: red; color: white; padding: 5px; text-align: center;">  DANGER </div> <p>Electric shock hazard! Because of size constraints, the supply voltage, output voltage and USB socket are not galvanically isolated. This means that the device has common digital and analog grounds, which are connected to the housing.</p>
---	---

Thanks to its modular design, the 8630 strain-gage torque sensor can be configured exactly to suit the application required:

- mV/V with standardized output signal
- mV/V with non-standardized output signal and burster TEDS
- ± 10 V output signal, configuration via USB
- ± 10 V output signal, configuration and measurement via USB

With the built-in amplifier option, the 8630 torque sensor outputs directly a torque-proportional voltage of 0 ... ± 10 V. The Micro USB port can be used to configure the 8630 torque sensor. For instance it is possible to set a filter frequency, configure averaging and set a tare function. With the USB option, in addition to the voltage output, the measurement function is available via USB as well. The sensor comes with the DigiVision PC software for performing measurements and data archiving, and drivers for DASYPAL and LabVIEW are available. Integration into custom software is possible via DLL. The burster

TEDS option (Transducer Electronic Data Sheet; a memory chip containing sensor-specific data and characteristics) allows rapid configuration of compatible evaluation units (instrumentation amplifiers, indicators/meters, process controllers etc.)

3.3.1 8630 torque sensor with bridge output

The 8630 torque sensor with bridge output has a 7-pin circular connector. This connector is used to supply the sensor with its required rated excitation voltage and to output the measurement signal in mV/V. The supply voltage must be kept absolutely constant. Conventional power supplies cannot guarantee this consistency to an adequate degree. Use an instrumentation amplifier, indicator or process controller that can provide a stabilized supply voltage and processes the mV/V signal.

Torque sensor model 8630-XXXX-VXX3X0

The model 8630-XXXX-VXX3X0 torque sensor provides a standardized output signal, i.e. all model 8630-XXXX-VXX3X0 torque sensors provide the same rated output for each measuring range. Each measuring range has a different rated output, however.

Torque sensor model 8630-XXXX-VXX4X0

The 8630-XXXX-VXX4X0 torque sensor provides all the functions of the 8630-XXXX-VXX3X0 torque sensor plus an internal burster TEDS chip. The burster TEDS chip stores all the characteristic data for the 8630-XXXX-VXX4X0 torque sensor, the model name and serial number. This ensures Plug&Play capability of the 8630-XXXX-VXX4X0 torque sensor with suitable indicating instruments such as the TRANS CAL 7281 and DIGIFORCE® 9311 or DIGIFORCE® 9307, dispensing with the time-consuming task of configuration.

Schematic diagram

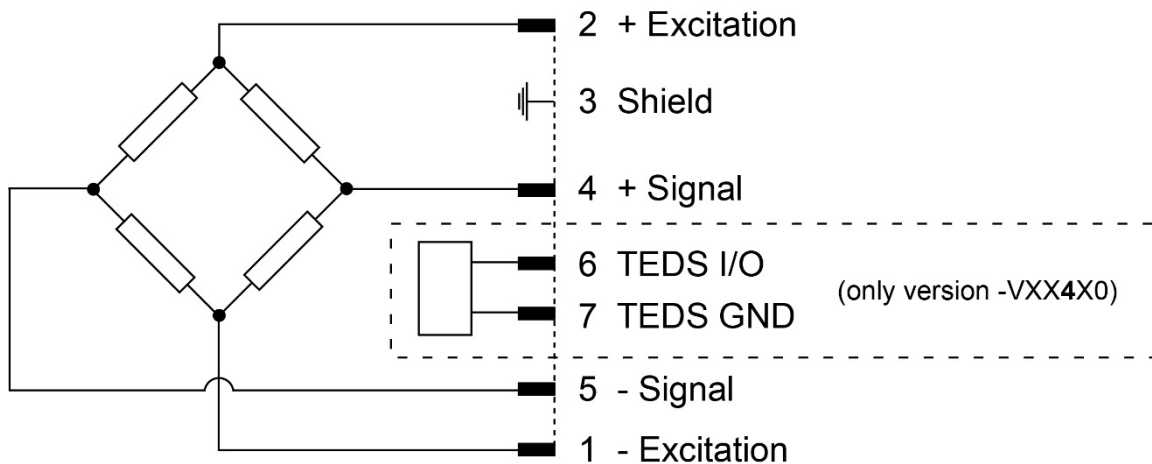

Figure 3: Model 8630-XXXX-VXX3X0 output mV/V
Model 8630-XXXX-VXX4X0 output mV/V and TEDS

IMPORTANT: The housing of the 8630 torque sensor must be grounded.

Torque Sensor 8630

3.3.2 8630 torque sensor with amplifier

The 8630 torque sensor with built-in amplifier has two connectors, offering alternative options for operation:

1. 7-pin circular connector, and
2. Micro USB socket

Schematic diagram

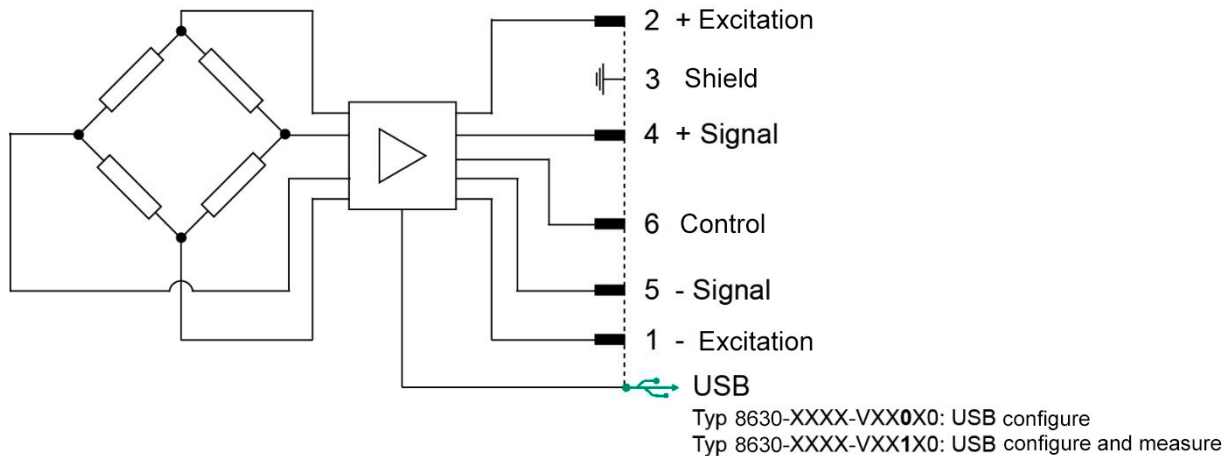

Figure 4: Model 8630-XXXX-VXX0X0 output 0 ... ± 10 V incl. configure via USB
Model 8630-XXXX-VXX1X0 output 0 ... ± 10 V incl. configure/measure via USB

Note: Shield, - Excitation, - Signal and USB GND are connected to the housing.

IMPORTANT: The housing of the 8630 torque sensor must be grounded.

Torque sensor model 8630-XXXX-VXX0X0

The Micro USB socket on the 8630-XXXX-VXX0X0 torque sensor is used for configuring the 8630-XXXX-VXX0X0 torque sensor, or specifically its analog output. Disconnect the plug from the circular connector while configuration is in progress to prevent ground loops. The 8630-XXXX-VXX0X0 torque sensor is supplied with power via the USB cable in this operating mode.

The following options can be configured:

a) The averaging function

You can set here the number of individual measured values to be used to form an arithmetic mean. The value can be set in the range $N = 1$ to $N = 50\,000$. When $N = 1$, averaging is not performed. In this case, the voltage value at the output is refreshed every $10\ \mu\text{s}$. This corresponds to $10\,000$ digitizations per second.

So if you select $N = 50\,000$, for example, then a measuring time of 5 seconds is needed for a new voltage value at the output ($50\,000 \times 10\ \mu\text{s} = 5\ \text{s}$). Disable the low-pass filter if you set a value $N \neq 1$.

b) The low-pass filter

The low-pass filter is a digital filter designed as a first-order low-pass filter.

Apart from the "OFF" setting, you can select various cut-off frequencies:

- OFF
- 5 Hz
- 10 Hz
- 25 Hz

- 50 Hz
- 100 Hz
- 200 Hz
- 400 Hz
- 1 kHz

Set the averaging value to $N = 1$ if you select a cut-off frequency \neq OFF.

The cut-off frequency is the frequency at which the output signal is attenuated by -3 dB, corresponding to about 70.7 % of the signal at very low frequencies.

Factory settings

- Averaging: $N = 100$
- Low-pass filter: OFF

Programming instructions

The dedicated interface manual available at www.burster.com contains precise details of the programming instructions. When using the DigiVision PC software, you can configure the sensor via the user interface.

Version 8630-XXXX-VXX1X0

The model 8630-XXXX-VXX1X0 torque sensor provides all the functions of the 8630-XXXX-VXX0X0 plus the option to read the measured values via the USB port. When using the DigiVision PC software, you can configure the sensor and display and record the measured values via the user interface. You can use the DigiVision Light version free of charge and download it via the download area on our website www.burster.dcom. You can find more information about the DigiVision software and its use in the accompanying operation manual (<https://bit.ly/3Ls86wO>).

	NOTICE
	<ul style="list-style-type: none"> • Choose to use either the circular socket or the USB socket, but not both, to avoid ground loops. • Choose between the voltage output or USB for measurement readings. Doing both at once is not possible.

3.4 Static and quasi-static torques

Static and quasi-static torques change their value only slowly or not at all. As long as they are below the rated torque, these torques can take any value.

Torque Sensor 8630

3.5 Dynamic torques

A dynamic torque changes very rapidly and can even oscillate. In this case the frequency of the torque must remain well below the resonant frequency of the mechanical structure as a whole.

	NOTICE
	<p>Resonance hazard Operating the 8630 torque sensor or the entire test setup close to its resonant frequency will result in permanent damage. Keep the torque frequency well below the resonant frequency of the mechanical test setup. Limit the peak-to-peak torque variation to 70 % of the rated torque.</p>

We recommend that you measure dynamic torques only if they do not exceed 70 % of the rated torque. The characteristics of your signal analysis and control systems must be taken into account during dynamic testing.

Estimating the mechanical resonant frequency

As a first approximation, the resonant frequency of the entire test setup depends on the spring constant “c” of the model 8630 torque sensor and the moment of inertia “J” of the attached components.

$$f_0 = \frac{1}{2 \cdot \pi} \cdot \sqrt{\frac{c}{J}}$$

- f₀: Resonant frequency in Hz
- J: Moment of inertia in kg · m²
- c: Spring constant in Nm / rad

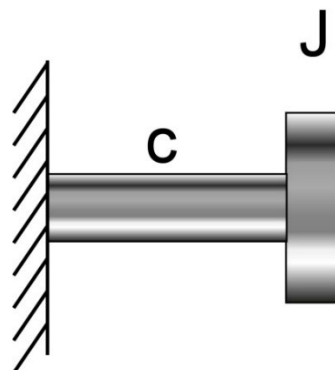

Figure 5: Resonant frequency model

Another method you can use to calculate resonant frequencies is the Holzer-Tolle method.

3.6 Interference

Possible sources of interference:

- Temperature change
- Temperature gradient
- Vibration
- Spurious forces
- EMC
- Electrical interference
- Magnetic interference
- Angular, axial or radial shaft misalignment

IMPORTANT: Take suitable measures to counter these sources of interference because otherwise they may cause an incorrect measurement result, e.g. provide covers or take measures to isolate from vibration.

3.7 Troubleshooting table

This table contains the most common faults and errors with relevant corrective actions.

Fault	Possible cause	Remedial action
No signal	No power supply	Connect supply
	Outside permitted range	Check supply
	No mains supply	Connect supply
	Cable faulty	Repair cable
	Signal output not connected correctly	Connect output correctly
	Electronic evaluation circuit faulty	Repair or replace
Sensor does not respond to torque	Shaft not clamped	Clamp correctly
	No power supply	Connect supply
	No mains supply	Connect supply
	Outside permitted range	Check supply
	Cable faulty	Repair cable
	Plug not connected correctly	Connect plug correctly
Signal drops out	Cable faulty	Repair cable
Zero point out of tolerance	Cable faulty	Repair cable
	Shaft under tension when fitted	Fit correctly
	Tension on shaft	Release tension
	Strong off-axis loads	Reduce off-axis loads
	Shaft overloaded	Return the 8630 torque sensor to the manufacturer
Torque reading incorrect	Calibration not correct	Recalibrate
	8630 torque sensor is faulty	Return to manufacturer for repair
	Torque bypass	Remove bypass
Torque fluctuations	Vibrations	Isolate from vibrations
	Air movements	Fit cover

Torque Sensor 8630

4. Installation

4.1 Mechanical installation

	NOTICE
	<p>Avoid excessive torques, bending moments or axial loads. Excessive torques, bending moments or axial loads may damage the 8630 torque sensor.</p> <ul style="list-style-type: none"> Connect the electrical cable to the 8630 torque sensor during fitting and monitor the measurement signal. This signal must remain within the permitted range. Support the 8630 torque sensor during fitting to make sure it does not drop, and do not resort to hammering to aid installation.

Make sure you fit the 8630 torque sensor the correct way round. The housing is fitted to the drive side of the sensor. The side of the 8630 torque sensor to be used for measurement is labeled "TEST SIDE":

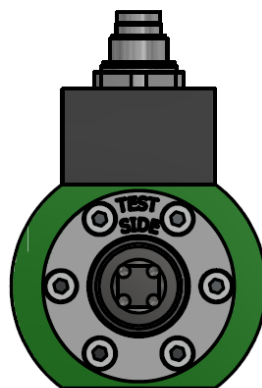



Figure 6: Test side, model 8630 torque sensor

If you get the ends mixed up you must expect the following effects:

- The cable connection will affect the measurement.
- The inertial masses of the housing will affect the measurement.

4.1.1 Preparing for alignment and fitting

	<h3>NOTICE</h3>
<p>Torque sensors with small rated torques are very sensitive to any overload. Carelessness even during fitting, for instance when tightening the couplings, can overload torque sensors.</p> <ul style="list-style-type: none"> • Connect the electrical cable to the 8630 torque sensor during fitting and monitor the measurement signal. Make sure that the torque never exceeds the maximum value (full scale) at any time. • Support the 8630 torque sensor during fitting to prevent any bending moments acting on the shaft. • Impacts and shocks may damage the model 8630 torque sensor (e.g. if it is dropped). Exercise due care when handling and fitting the 8630 torque sensor. 	

Additional instructions for correct installation of the 8630 torque sensor:

- Note:** Ensure that the shaft and mating parts are completely clean and have no traces of lubricants or foreign matter at the time of fitting. Use a solvent such as acetone to clean the shafts before fitting.
- Note:** Use only the appropriate burster accessories such as flange adapter or bracket to ensure correct installation of the 8630 torque sensor.
- Note:** Fit the 8630 torque sensor loosely at first before alignment. Do not tighten the screws on adapters at this stage.
- Note:** Make sure the whole assembly is exactly in line when aligning the 8630 torque sensor and/or the shafts. Normally a straight edge is sufficient to achieve alignment in two mutually orthogonal planes. We do recommend, however, using a dial gage or laser for alignment.
- Note:** Connect the electrical cable to the 8630 torque sensor during fitting and monitor the measurement signal. Tighten the fixing screws to the specified tightening torques using a torque wrench. Make sure that the measurement signal does not exceed the maximum torque (full scale) during tightening.

Torque Sensor 8630

4.1.2 Installation options

The 8630 static torque sensors can be fitted in a variety of ways.

Direct installation

The model 8630 torque sensors, measuring range up to 10 Nm, can be attached directly to the system structure. The 8630 torque sensor provides blind threaded holes and locating-pin holes on the underside of the housing for this purpose. The blind threaded holes are used for screw-fastening the sensor to the system. To correct for any tolerances and play in the threaded holes and screws, the model 8630 torque sensor can be fixed precisely in place using the tightly-toleranced holes for mating locating pins. This makes it easier to replace a sensor, because it dispenses with time-consuming re-alignment.

Note: The blind threaded holes must not be used as a torque support.

Note: The torque must be applied via both shaft ends, otherwise the sensor may be damaged.

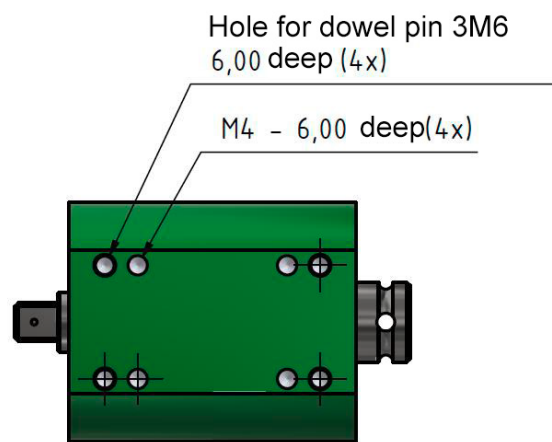

Figure 7: Blind threaded holes and locating-pin holes – underside

On its end face on the drive side, the 8630 torque sensor has six blind threaded holes for fixing the sensor to its surrounding application. Tighten the screws in a diagonal pattern to the specified tightening torque. You can also attach the 8630 torque sensor directly on the drive side by means of the shaft.

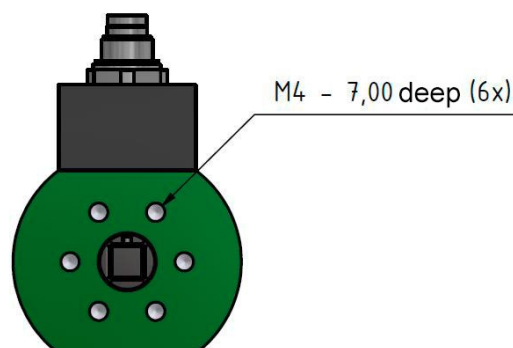

Figure 8: Blind threaded holes – drive side

Installation using a mounting flange

The 8630 torque sensor can be supplied with a mounting flange. This mounting flange is fitted in the factory and allows the 8630 torque sensor to be attached easily to the system structure. For versatile fitting options, each flange has four through-holes and four threaded holes. Always tighten the fixing screws in a star pattern. If the 8630 torque sensor is supplied fitted with a mounting flange (sensor model 8630-XXXX-VXXX40), this flange forms an integral part of the 8630 torque sensor and is calibrated with the sensor. The mounting flange must always be included in any recalibrations.

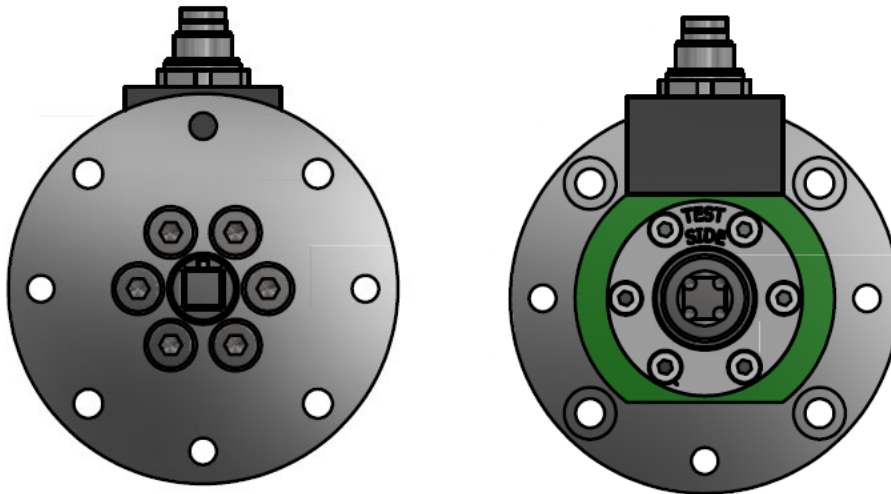

Figure 9: Mounting flange for simple attachment – view of the drive side / test side

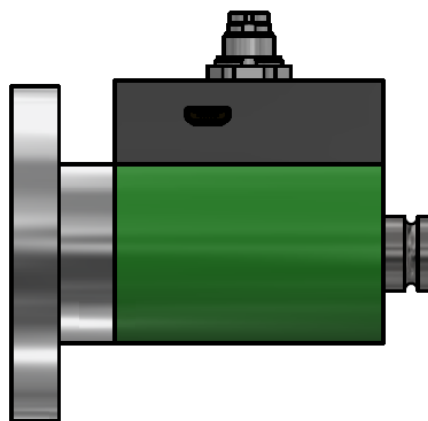

Figure 10: Mounting flange for simple attachment – side view

Torque Sensor 8630

Installation using a bracket

The 8630 torque sensor can be supplied with a bracket as an accessory. This bracket must be fitted independently by the customer and is not included in the calibration.

The bracket is screwed onto the drive side of the 8630 torque sensor using six fixing screws. The screws must always be tightened in a star pattern to the specified tightening torques. Various screw holes allow a choice of options for attaching the bracket to the system structure. In addition, the bracket includes two locating grooves in its base and a cable fixing means.

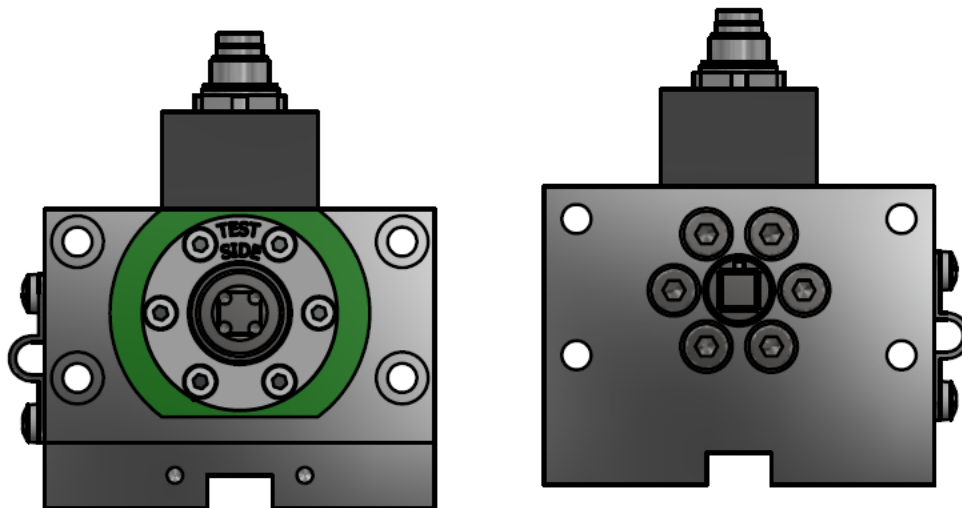

Figure 11: Bracket for simple attachment – view of the test side / drive side

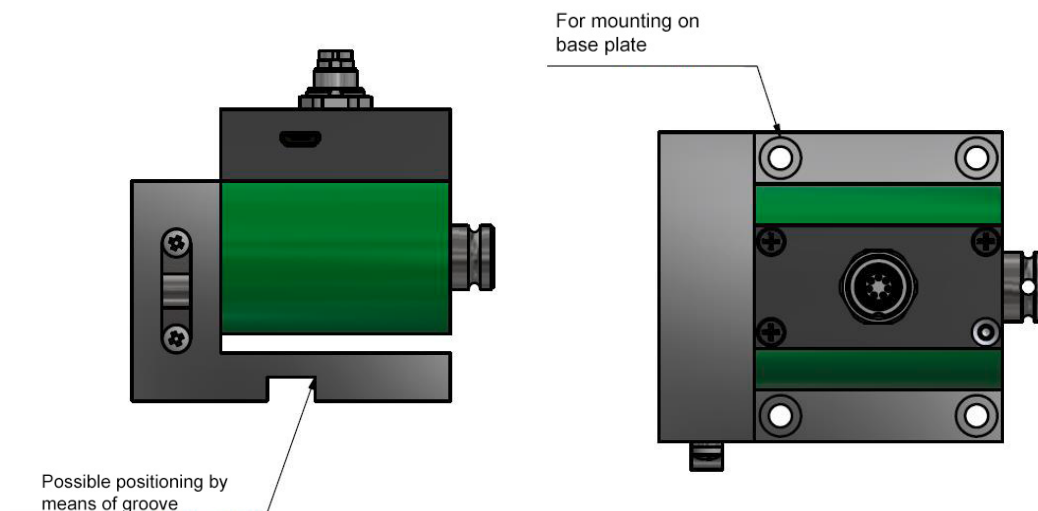

Figure 12: Bracket for simple attachment – side view

4.2 Electrical connection

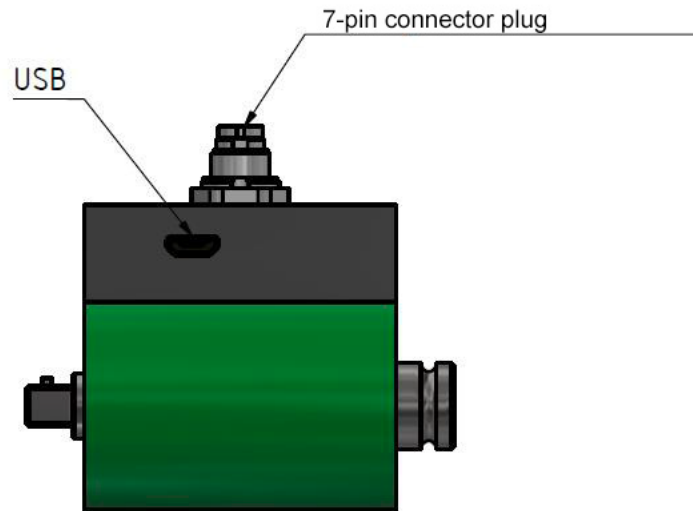





Figure 13: Electrical connection

4.2.1 Power supply

	 <h2 style="margin: 0;">DANGER</h2>
<p>Electric shock hazard! Because of size constraints, the supply voltage, output voltage and USB socket are not galvanically isolated. This means that the device has common digital and analog grounds, which are connected to the housing.</p>	

	<h2 style="margin: 0;">NOTICE</h2>
<ul style="list-style-type: none"> • Choose to use either the circular socket or the USB socket, but not both, to avoid ground loops. • Choose between the voltage output or USB for measurement readings. Doing both at once is not possible. 	

Torque Sensor 8630

4.2.2 Pin-out of the electrical socket

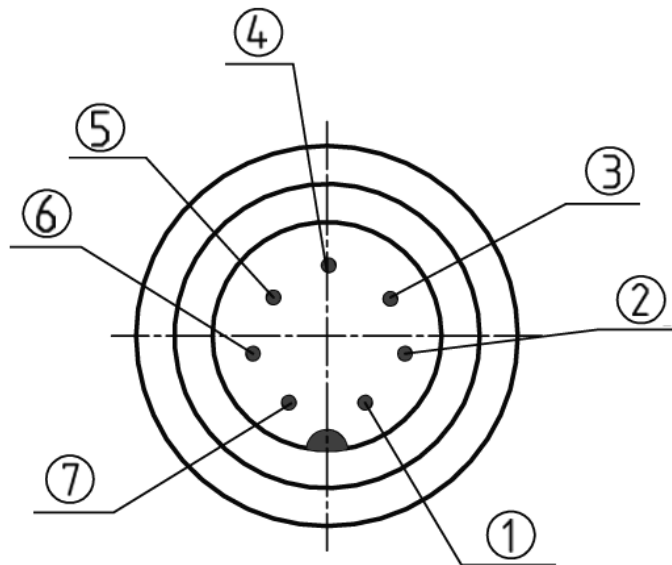

Figure 14: View from the solder side

The connector pin assignment depends on the selected options

Pin	Pin-out without built-in electronics	Pin-out with built-in electronics
1	Bridge excitation -	Excitation GND
2	Bridge excitation +	Excitation +5 ... 30 V
3	Shield	Shield
4	Signal +	Output signal ± 10 V
5	Signal -	Output signal GND
6	TEDS I/O (option) / NC	Check signal
7	TEDS GND (option) / NC	Range switching (option)

4.2.3 Pin-out of the USB connector

The USB interface complies with the USB 2.0 standard and the pin assignment is as usual. The built-in connector on the 8630 torque sensor is for a "Micro USB" plug.

Pin	Name
1	+5 V
2	Data -
3	Data +
4	ID (not used)
5	GND

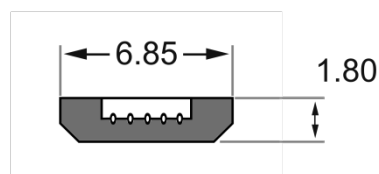

Figure 15: Micro USB [mm]

The connector fitted on the supplied cable is a “USB Type A” plug.

Pin	Name
1	+5 V
2	Data -
3	Data +
4	GND

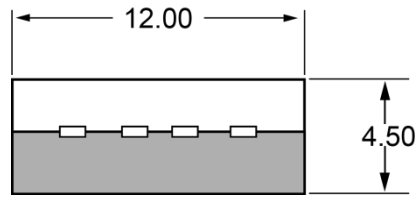

Figure 16: USB A [mm]

4.2.4 Power supply for the 8630 torque sensor fitted with USB

The device draws 200 mA from the USB port. Usually this is not a problem for desktop PCs.

For laptops, however, several USB ports may share one power supply that is additionally loaded by other connected USB devices (mouse etc.) Therefore under some circumstances the 8630 torque sensor may be supplied with too little power and cannot register its presence. In this case, you need to connect the 8630 torque sensor to the laptop via an active USB hub.

Alternatively, for configuration purposes you can provide the 8630 torque sensor with power via the circular connector. In this case we recommend an excitation voltage of at least 24 V DC. This excitation voltage is interlocked with respect to the USB port. Make sure that no ground loops can arise.

Note: The actual power consumption is: $P = 5 \text{ V} * 0.2 \text{ A} = 1 \text{ VA}$.

4.2.5 Power supply for the 8630 torque sensor with built-in electronics via the circular connector

The 8630 torque sensor works in an operating voltage range of 5 ... 30 V DC – measured at the 8630 torque sensor. When using cables of small cross-section or with an extension, you must take into account the voltage drop in the cable. In this case set the operating voltage slightly higher. The power consumption is about 1 W.

Torque Sensor 8630

4.2.6 Power supply for the 8630 torque sensor without built-in electronics

No additional supply voltage is needed because of the bridge excitation voltage.

4.2.7 Cable

- Always use shielded, low-capacitance cables.
- We recommend cables from burster präzisionsmesstechnik gmbh & co kg. These cables meet the relevant requirements.
- Make sure that the cable cross-section is sufficient.

Relationship between sensor rated output and cable length

With extension cables, the sensor rated output is affected by the cable length as a function of the bridge resistance and the conductor cross-section. Therefore always order extension cables at the same time as ordering the 8630 torque sensor. Make sure that calibration is performed on the complete assembly of the 8630 torque sensor plus extension cables.

Note: When extending cables, make sure connections are made correctly and with proper isolation.

When calculating the cable resistance you must take into account both excitation leads for the 8630 torque sensor.

i.e.

Cable resistance = 2x resistance of the cable length

burster präzisionsmesstechnik gmbh & co kg calibrates all sensors in combination with the cable length ordered. In these cases you do not need to take account of the cable length.

Difference per meter of cable length

Conductor cross-section	Cable resistance per m	For 350 Ω bridge resistance	For 700 Ω bridge resistance	For 1000 Ω bridge resistance
0.14 mm ²	0.28 Ω	0.08 %	0.04 %	0.028 %
0.25 mm ²	0.16 Ω	0.046 %	0.023 %	0.016 %
0.34 mm ²	0.12 Ω	0.034 %	0.017 %	0.012 %

4.2.8 Connecting the shield

The shield together with the 8630 torque sensor and the external electronics form a Faraday cage. Thanks to this cage, electromagnetic interference usually does not affect the measurement signal.

IMPORTANT: The 8630 torque sensor must always be grounded reliably by means of its fixing screws. In some cases it may be necessary not to attach the cable shield to the indicating equipment.

4.2.9 Running cables

Electrical and magnetic fields can often be picked up by the test leads, causing interference. Such interference mainly stems from power cables running parallel to the test leads, but can also be caused by contactors, thyristor controllers, variable frequency drives and electric motors in the vicinity. Ensure these are a sufficient distance away and route test leads through a grounded steel pipe if necessary.

Galvanic interference can also occur, particularly if the measurement chain is grounded at multiple points creating differences in electrical potential. These ground loop currents can be avoided by either disconnecting the double grounding or bypassing it by running a particularly low-resistance ground cable (6-10 mm²) parallel to the test lead.

In general the following applies:

- The 8630 torque sensor must be grounded via its mounting screws.
- Run the cable loosely and with enough play in the cable to allow for any movement.
- Avoid any tension on the connecting plug.
- Avoid excessive lengths. If that is not possible, snake the cable. This will reduce the effective induction area.

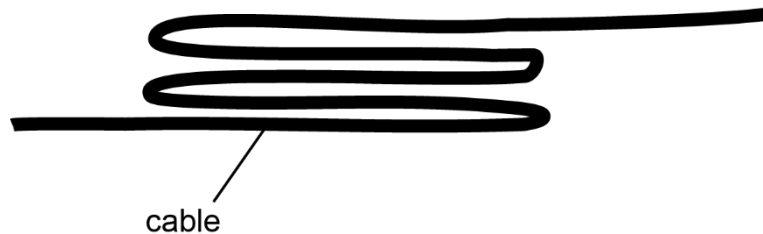

Figure 17: Running a cable with excess length

- Position the model 8630 torque sensor outside of the electromagnetic field of high-energy equipment. This includes transformers, motors, contactors, frequency converters and so forth. Otherwise the electromagnetic fields from such equipment will act with their full effect on the measuring chain, causing incorrect measurements.

IMPORTANT: Route the measuring leads separately from power cables. If the measuring leads are laid parallel to such cables, the latter will cause inductive and capacitive interference.

Note: In some cases it is helpful to pull an extra shield as additional protection over the measuring cable, or to lay the cable in a metal tube or pipe, which should additionally be grounded if necessary.

Torque Sensor 8630

4.3 Measurement operation

4.3.1 Switching on



This is how it works

1. Apply the operating voltage to the model 8630 torque sensor.

4.3.2 The torque direction

A torque is clockwise (clockwise torque) if the torque is exerted clockwise when **looking at the test side**. In this case you will get a positive electrical signal at the output from the 8630 torque sensor.

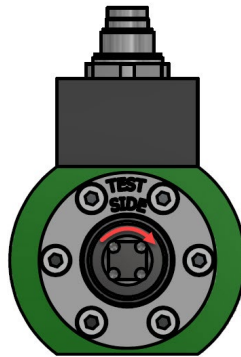

Figure 18: Clockwise torque (looking at the test side)

You can use model 8630 torque sensors to measure both clockwise and counterclockwise torques. If the torque is exerted in a counterclockwise direction (looking at the test side), you will get a negative signal at the output.

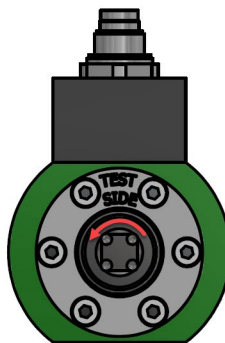

Figure 19: Counterclockwise torque (looking at the test side)

4.3.3 Check function (for 8630 with instrumentation amplifier)

The 8630 torque sensor with analog output has a check function. This check function is actuated electronically by applying the supply voltage (Excitation +) additionally to Pin 6 of the connector. As long as this voltage is applied to Pin 6, a precise voltage of 10.00 V is available at the output of the 8630 torque sensor. This can be used to calibrate indicators, input boards or other evaluation equipment connected to the output of the sensor.

Note: Use the check signal only when the 8630 torque sensor is not under load.

Example showing check signal connection

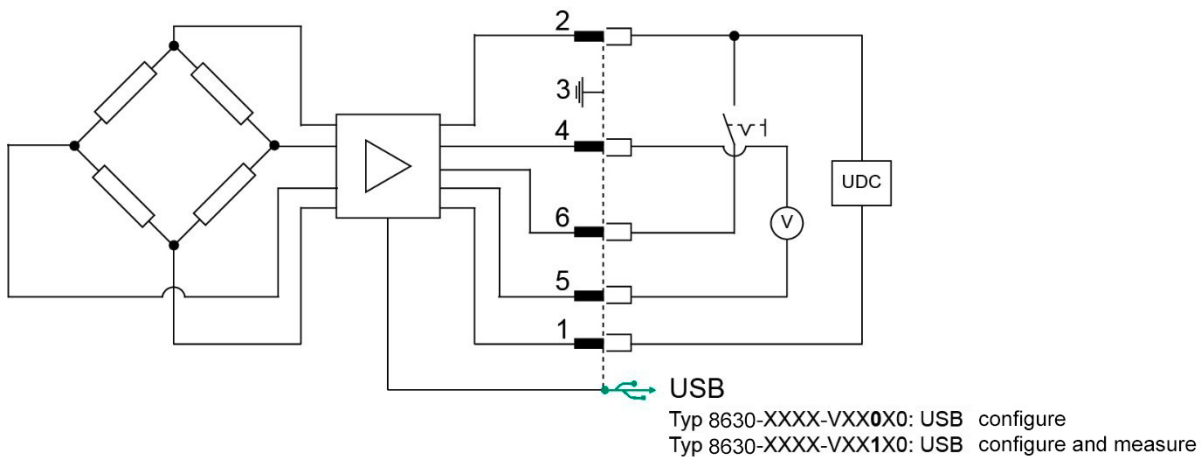

Figure 20: Example showing check signal connection

Pin	Function
1	Excitation - (= housing)
2	Excitation +
3	Shield (= housing)
4	Signal +
5	Signal - (= housing)
6	Check
7	NC

IMPORTANT: The housing of the 8630 torque sensor must be grounded.

4.3.4 Dual-range sensor

The sensor with two measuring ranges has the same dimensions as the standard version but features two separately calibrated measuring ranges. The measuring ranges are switched within <50 ms, even during measuring operation, by applying the operating voltage to pin 7 or via USB (<https://bit.ly/3Ls86wO>). The available ratios can be found in the current data sheet. The latest version of the data sheet is available at <https://bit.ly/32UV2i7>.

5. Calibration and adjustment

Model 8630 torque sensors from burster präzisionsmesstechnik gmbh & co kg are already traceably adjusted and tested in the factory. As an option, we offer DAkkS or factory calibration of the model 8630 torque sensor.

5.1 Factory calibration

As part of the traceable burster factory calibration, the 8630 torque sensor is checked for calibratability, and is then calibrated and marked with a calibration label, and a calibration certificate is issued.

The burster factory calibration certificate includes the following information as a minimum:

- Measurement values and measurement uncertainty
- Reference standards used including measurement uncertainty and traceability
- Zero offset, rated output and interpolation error
- Peak-to-peak range and hysteresis voltage

5.2 Calibration certificate with accreditation symbol

Calibration of the model 8630 torque sensor is carried out by an ISO 17025 accredited calibration laboratory (DAkkS). Calibration is carried out according to DIN 51309 with 8 torque levels.

It is essentially the user's responsibility to determine appropriate periods for recalibration. In the case of an accredited calibration, the user should note that according to current standards (DIN 51309), the validity of the calibration lasts for no longer than 26 months.

5.3 Recalibration

Quality management standards require regular calibration of any measurement and test equipment that you use in quality-related processes. The reason for this is to ensure measurements are always made correctly, thereby keeping the risk of measurement errors in check.

We recommend that all measurement and test equipment is inspected every 12 months. We advise an immediate inspection if any damage is suspected.

Shorter intervals are recommended in the following cases:

- Overload of the 8630 torque sensor
- Following a repair or overhaul
- After improper use of the model 8630 torque sensor
- When required by quality standards
- Where there is a specific traceability requirement

If you have any questions about the 8630 torque sensor or calibration, please contact our Customer Service team by phone on +49 7224 645-53 or by email at service@burster.de.

6. Taking out of use

- Remove the 8630 torque sensor properly.
- Protect the 8630 torque sensor from knocks.
- Protect the 8630 torque sensor against bending moments.
- Support the model 8630 torque sensor.
- Do not drop the model 8630 torque sensor **under any circumstances**.

Torque Sensor 8630

7. Technical data

Please refer to the enclosed data sheet for the technical specification. The latest version of the data sheet is available at <https://tinyurl.com/2x6ysd4e>.



Figure 21: Technical data QR code

7.1 Electromagnetic compatibility

Interference immunity

Interference immunity in compliance with EN 61326-2-3:2006
Industrial environment

Interference emission

Interference emission in compliance with EN 61326-2-3:2006

8. Accessories available

Please refer to the enclosed data sheet for details of the accessories available. The latest version of the data sheet is available at <https://tinyurl.com/2x6ysd4e>.



Figure 22: Accessories available

9. Disposal



Disposal

If your torque sensor is no longer usable, please comply with your legal obligations by disposing of it in accordance with applicable regulations. You will then be helping to protect the environment!