

Precision Miniature Tension and Compression Load Cell

MODEL 8431, MODEL 8432 with overload protection



8431

8432

Highlights

- Measuring ranges from 0 ... 2.5 N up to 0 ... 100 kN
- Protection class IP65
- Very robust against lateral forces due to supporting membranes
- Relative non-linearity from 0.15 % F.S.
- Model 8432 with overload protection for directions tension and compression

Options

- Compensated temperature range from -55 °C ... +120 °C
- Vacuum compatible design
- Various attachments available
- Dragchain cable

Applications

- Machinery manufacture
- Tool manufacturing
- Handling gear
- Bar works



Sensor with rod end bearings



8431 various measuring ranges



8432 various measuring ranges

Product description

These models are among our most precise and yet mechanically robust miniature load cells. High accuracy, finely graded measuring ranges, small dimensions and the simple introduction of force via opposing threaded pins open up a wide scope of laboratory and production applications. Their sophisticated engineering with integrated support membranes and overload protection reduces additional design expense in many applications, e.g. for external overload protection or guiding the parts introducing force to the cell. The result is that less space is required, less material is used and less weight is involved. Last but not least, there is hardly any friction on components that could falsify the measurement result.

The force to be measured is introduced centrally and axially to the cylindrical sensor body in the tension or compression direction by means of the two threaded pins. This requires the sensor to be mounted without any elements touching the end faces of the sensor housing. Two stabilizing support membranes inside the sensors for the smaller measurement ranges minimize the effect of lateral forces and moments, while also ensuring long-term mechanical measuring stability. Even though the precision miniature load cell is designed to isolate the measuring element from external forces, torsion and bending moments on the sensor axis should be avoided. The sensors work position independent. They have an active side which acts directly on the measuring element, whereas the passive side is fixed to the housing.

Technical Data

8431	-	5	5010	5020	5050	5100	5200	5500	
Measuring range calibrated in N and kN from 0 ...		±5 N	±10 N	±20 N	±50 N	±100 N	±200 N	±500 N	
		±1.24 lbs	±2.24 lbs	±4.49 lbs	±11.2 lbs	±22.5 lbs	±45.0 lbs	±112.4 lbs	
Accuracy									
Relative non-linearity*		≤ ±0.15 % F.S.							
Characteristic curve deviation*		≤ ±0.15 % F.S.							
Relative hysteresis		≤ 0.30 % F.S.	≤ 0.25 % F.S.						
Temperature effect on zero output		≤ ±0.05 % F.S./K	≤ ±0.03 % F.S./K						
Temperature effect on nominal sensitivity		≤ ±0.05 % F.S./K	≤ ±0.03 % F.S./K						
Electrical value									
Sensitivity nominal		15 mV/V ... 40 mV/V	0.4 mV/V	0.8 mV/V	2 mV/V				
Measurement direction		8431-5: Tension and compression direction. Calibration in the preferred direction of tension force. The full-scale output is likely to be different when used in the compression direction. from 8431-5010: Tension and compression direction. Calibration in the preferred direction of compression force. The full-scale output is likely to be different when used in the tension direction.							
Standardization		only for measuring ranges ≥ 0 ... 50 N, to 1.5 mV/V (±0.25 %), option realized on an circuit board 48 x 7 mm (L x W) at the cable after 1.7 m from sensor or 0.3 m from cable end							
Bridge resistance		ca. 500 Ω nominal	ca. 350 Ω nominal						
Excitation		recommended 5 V DC							
Insulation resistance		30 MΩ at 45 V DC							
Calibration resistance		8431-5: 200 kΩ ±0.1 %; from 8431-5010: 59 kΩ ±0.1 % The bridge output voltage caused by a shunt of this value is given in the calibration protocol.							
Environmental conditions									
Nominal temperature range**		+15 °C ... +70 °C							
Operating temperature range**		-55 °C ... +120 °C (optional cable with drag chain capability -30 °C ... +100 °C)							
Mechanical values									
Deflection full scale	[µm]	15 ... 40							
Maximum operating force bidirectional		150 % of capacity							
Overload burst		200 % of capacity							
Dynamic performance		recommended: 50 % of capacity maximum: 70 % of capacity							
Protection class (EN 60529)		IP65							
Other		5	5010	5020	5050	5100	5200	5500	
Material		stainless steel 1.4542							
Natural frequency	[kHz]	0.3		0.7	0.9	1.2	2.7	3.3	
Mass without cable	[g]	18				34			
Thread adapter ***		8431-Zx01				8431-Zx02			

* The data in the area 20 % - 100 %

** Temperature range for the optional TEDS or standardization board 0 ... 60 °C

*** Spare part orders of the thread adapter require the specification of the serial number of the sensor



Technical Data

8431	-	6001	6002	6005	6010	6020	6050	6100
Measuring range calibrated in N and kN from 0 ...		±1 kN	±2 kN	±5 kN	±10 kN	±20 kN	±50 kN	±100 kN
		±225.0 lbs	±450.0 lbs	±1.1 klbs	±2.2 klbs	±4.5 klbs	±11.2 klbs	±22.5 klbs
Accuracy								
Relative non-linearity*		≤ ±0.15 % F.S.						
Characteristic curve deviation*		≤ ±0.15 % F.S.	≤ ±0.20 % F.S.					
Relative hysteresis		≤ 0.25 % F.S.						
Temperature effect on zero output		≤ ±0.03 % F.S./K						
Temperature effect on nominal sensitivity		≤ ±0.03 % F.S./K						
Electrical value								
Sensitivity nominal		2 mV/V						
Measurement direction		Tension and compression direction. Calibration in the preferred direction of compression force. The full-scale output is likely to be different when used in the tension direction.						
Standardization		to 1.5 mV/V (±0.25 %), option realized on an circuit board 48 x 7 mm (L x W) at the cable after 1.7 m from sensor or 0.3 m from cable end						
Bridge resistance		ca. 350 Ω nominal						
Excitation		recommended 5 V DC						
Insulation resistance		30 MΩ at 45 V DC						
Calibration resistance		59 kΩ ±0.1 % The bridge output voltage caused by a shunt of this value is given in the calibration protocol.						
Environmental conditions								
Nominal temperature range**		+15 °C ... +70 °C						
Operating temperature range**		-55 °C ... +120 °C (optional cable with drag chain capability -30 °C ... +100 °C)						
Mechanical values								
Deflection full scale	[µm]	15 ... 40						
Maximum operating force bidirectional		150 % of capacity						
Overload burst		200 % of capacity						
Dynamic performance		recommended: 50 % of capacity maximum: 70 % of capacity						
Protection class (EN 60529)		IP65						
Other		6001	6002	6005	6010	6020	6050	6100
Material		stainless steel 1.4542						
Natural frequency	[kHz]	5.3	7.5	9.7	1.3	1.0		0.5
Mass without cable	[g]		40		60	124	238	1124
Thread adapter ***		-						

* The data in the area 20 % - 100 %

** Temperature range for the optional TEDS or standardization board 0 ... 60 °C

*** Spare part orders of the thread adapter require the specification of the serial number of the sensor



Technical Data

8432	-	2.5	5005	5010	5020	5050
Measuring range calibrated in N and kN from 0 ...		±2.5 N	±5 N	±10 N	±20 N	±50 N
		±0.56 lbs	±1.24 lbs	±2.24 lbs	±4.49 lbs	±11.2 lbs
Accuracy						
Relative non-linearity*		≤ ±0.20 % F.S.				
Characteristic curve deviation*		≤ ±0.20 % F.S.				
Relative hysteresis		≤ 0.25 % F.S.				
Temperature effect on zero output		≤ ±0.05 % F.S./K	≤ ±0.03 % F.S./K			
Temperature effect on nominal sensitivity		≤ ±0.05 % F.S./K	≤ ±0.03 % F.S./K			
Electrical value						
Sensitivity nominal		15 mV/V nominal	0.75 mV/V nominal	1.5 mV/V nominal	2 mV/V	
Measurement direction		8432-2.5: Tension and compression direction. Calibration in the preferred direction of tension force. The full-scale output is likely to be different when used in the compression direction. from 8432-5005: Tension and compression direction. Calibration in the preferred direction of compression force. The full-scale output is likely to be different when used in the tension direction.				
Standardization		only for measuring ranges ≥ 0 ... 20 N, auf 1.5 mV/V (±0.25 %), option realized on an circuit board 48 x 7 mm (L x W) at the cable after 1.7 m from sensor or 0.3 m from cable end				
Bridge resistance		ca. 500 Ω nominal	ca. 350 Ω nominal			
Excitation		recommended 5 V DC				
Insulation resistance		30 MΩ at 45 V DC				
Calibration resistance		8432-2.5: 200 kΩ ±0.1 %; from 8432-5005: 59 kΩ ±0.1 % The bridge output voltage caused by a shunt of this value is given in the calibration protocol.				
Environmental conditions						
Nominal temperature range**		+15 °C ... +70 °C				
Operating temperature range**		-55 °C ... +120 °C (optional cable with drag chain capability -30 °C ... +100 °C)				
Mechanical values						
Deflection full scale	[µm]	15 ... 40				
Maximum operating force bidirectional		100 % of capacity (then overload protection takes effect)				
Maximum static load to overload stop		bidirectional 500 % of capacity				
Dynamic performance		recommended: 50 % of capacity maximum: 70 % of capacity				
Protection class (EN 60529)		IP65				
Other		2.5	5005	5010	5020	5050
Material		stainless steel 1.4542				
Natural frequency	[kHz]	0.2			0.35	0.6
Mass without cable	[g]	68				
Thread adapter ***		8432-Zx01				

* The data in the area 20 % - 100 %

** Temperature range for the optional TEDS or standardization board 0 ... 60 °C

*** Spare part orders of the thread adapter require the specification of the serial number of the sensor



Technical Data

8432	-	5100	5200	5500	6001	6002
Measuring range calibrated in N and kN from 0 ...		±100 N	±200 N	±500 N	±1 kN	±2 kN
		±22.5 lbs	±45.0 lbs	±112.4 lbs	±225.0 lbs	±450.0 lbs
Accuracy						
Relative non-linearity*		≤ ±0.20 % F.S.				
Characteristic curve deviation*		≤ ±0.20 % F.S.				≤ ±0.30 % F.S.
Relative hysteresis		≤ 0.25 % F.S.				
Temperature effect on zero output		≤ ±0.03 % F.S./K				
Temperature effect on nominal sensitivity		≤ ±0.03 % F.S./K				
Electrical value						
Kennwert nominell		2 mV/V				
Messrichtung		Tension and compression direction. Calibration in the preferred direction of compression force. The full-scale output is likely to be different when used in the tension direction.				
Standardisierung		to 1.5 mV/V (±0.25 %), option realized on an circuit board 48 x 7 mm (L x W) at the cable after 1.7 m from sensor or 0.3 m from cable end				
Brückenwiderstand		ca. 350 Ω nominal				
Speisespannung		recommended 5 V DC				
Isolationswiderstand		30 MΩ at 45 V DC				
Kalibrierwiderstand		59 kΩ ±0.1 % The bridge output voltage caused by a shunt of this value is given in the calibration protocol.				
Environmental conditions						
Nominal temperature range**		+15 °C ... +70 °C				
Operating temperature range**		-55 °C ... +120 °C (optional cable with drag chain capability -30 °C ... +100 °C)				
Mechanical values						
Deflection full scale	[µm]	15 ... 40				
Maximum operating force bidirectional		100 % of capacity (then overload protection takes effect)				
Maximum static load to overload stop		bidirectional 500 % of capacity		bidirectional 250 % of capacity	bidirectional 200 % of capacity	
Dynamic performance		recommended: 50 % of capacity maximum: 70 % of capacity				
Protection class (EN 60529)		IP65				
Other						
Material		5100 5200 5500 6001 6002 stainless steel 1.4542				
Natural frequency	[kHz]	1.2	2.7	3.3	3.4	3.8
Mass without cable	[g]	68			125	210
Thread adapter ***		8432-Zx02			8432-Zx03	8432-Zx04

* The data in the area 20 % - 100 %

** Temperature range for the optional TEDS or standardization board 0 ... 60 °C

*** Spare part orders of the thread adapter require the specification of the serial number of the sensor



Dimensional drawing **Model 8431** and **Model 8432**

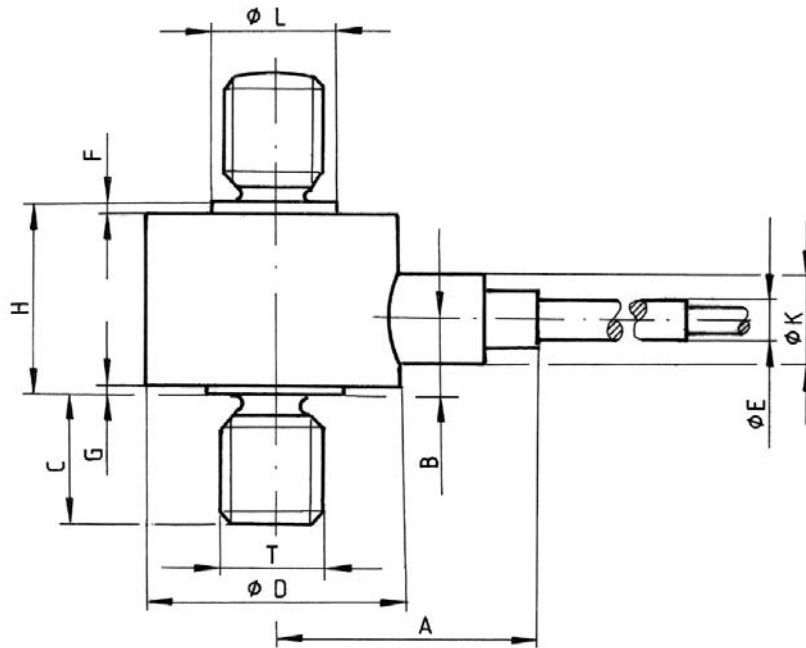

8431	-	5	5010	5020	5050	5100	5200	5500
Measuring range from 0 ...		±5 N	±10 N	±20 N	±50 N	±100 N	±200 N	±500 N
Geometry								
Ø D	[mm]	25.4	19			25.4		
H	[mm]	12.7			16.0			
Thread T		M4 x 0.7				M5 x 08		
C	[mm]	6.4						
A	[mm]	17.6				25.4		
F	[mm]	2.8	1.3			2.8		
G	[mm]	0.8	0.3			0.2		
B	[mm]	5.9			6.6			
Ø K	[mm]	4.8			6.4			
Ø L	[mm]	9.6	7.9			9.5		
Ø E	[mm]	-	2.5			3.6		
General tolerance of dimensioning		ISO 2768f						

8431	-	6001	6002	6005	6010	6020	6050	6100
Measuring range from 0 ...		±1 kN	±2 kN	±5 kN	±10 kN	±20 kN	±50 kN	±100 kN
Geometry								
Ø D	[mm]	25.4				31.8	35	60
H	[mm]	14			19.1	25.4	28.7	48
Thread T		M6 x 1.0			M10 x 1.5	M12 x 1.5	M20 x 1.5	M30 x 2.0
C	[mm]	9.7			12.7	16	22.4	42
A	[mm]	25.4			28.6		30.3	45
F	[mm]	0.8			0.3		0.5	
G	[mm]	0.5			-			
B	[mm]	7			6.5	14.2	15	23.6
Ø K	[mm]	6.4			9.5		13	
Ø L	[mm]	8.7			12.7	17.5	25	38
Ø E	[mm]	3.6			-			
General tolerance of dimensioning		ISO 2768f						

4216-008431 EN-5699-031 525



8432	-	2.5	5005	5010	5020	5050	5100	5200	5500	6001	6002
Measuring range from 0 ...		±2.5 N	±5 N	±10 N	±20 N	±50 N	±100 N	±200 N	±500 N	±1 kN	±2 kN
Geometry											
Ø D	[mm]	25.4						31.8		38.1	
H	[mm]	21.9						23.9		26.7	
Thread T		M4 x 0.7				M5 x 08				M6 x 1.0	
C	[mm]	6.4						8		9.6	
A	[mm]	25.4						28.6		31.8	
F	[mm]	2.8						2.6		0.7	
G	[mm]	0.2						0.3			
B	[mm]	9.6						10.7		14.9	
Ø K	[mm]	9.7	9.5			6.4			9.5		
Ø L	[mm]	9.5						9.0			
Ø E	[mm]	-	2.5			3.6					
General tolerance of dimensioning		ISO 2768f									

Permissible External Forces

Due to this precision miniature load cells construction with two stabilizing support membranes, it is only slightly sensitive to non-central forces applied to the sensor

The influence of these undesired external forces cannot be globally quantified with certainty. It depends on the sensor's measuring range and from which side the force is applied. As a rule of thumb, the amount of external force influence on the measurement signal is between 0.25 % and 1 % depending on the measurement range as long as it is within the range of the table.

The table shows the maximum percentage values that the external forces can have in relation to the respective measurement range of the load cell. The total of all loads on the load cell (forces and torques) should not exceed 100% of the measurement range

The torque entries refer to a gap of 25 mm from the point of force application to the sensor surface or the sensor axis.

End Value of Meas. Range up to	Shear Force (Lateral Force) [% F.S.]	Bending Torque (Bending Force) [% F.S.]	Torsion (Torque) [% F.S.]
0 ... 2 kN	50	40	25
0 ... 10 kN	30	25	25
0 ... 100 kN	20	20	10

Mounting	
Mounting instructions	<p>The force being measured has to be applied centrally and without lateral forces, via the threaded pin. There must not be any lateral clamping forces acting on the sensor as they could cause incorrect measurements or damage the unit.</p> <p>To ensure that the load cell is securely fixed in its installation position, it can be glued in place via the thread or secured with a locknut.</p> <p>During handling and installation, take care not to subject the cable outlet or sensor connection cable to excessive tensile or bending force. Effective strain relief should be installed if necessary.</p>

Electrical termination

Output signal

burster load cells are based on a strain-gage Wheatstone bridge. This measurement principle means that the output voltage mV/V is dependent on the sensor supply voltage. Our website contains details of suitable instrumentation amplifiers, indicator and display devices and process instruments.



burster TEDS

The "**burster T**ransducer **E**lectronic **D**ata **S**heet" (TEDS) is a memory in which identification data of the sensor, calibration data and other sensor parameters are saved. In conjunction with your own suitable burster device, there is the option of performing a simple adjustment in order to achieve the maximum accuracy of the measuring chain. A simple sensor exchange is thus possible in just a few steps without losing precision.

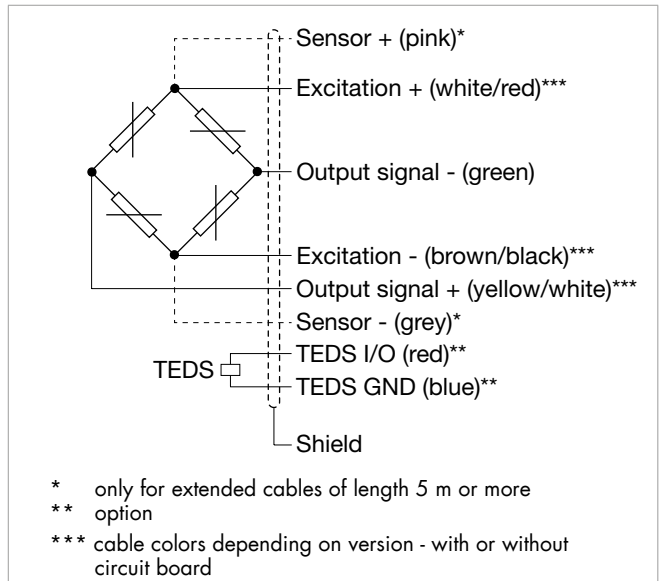

8431/8432	-	2.5	5005	5010	5020	5050	5100	5200	5500	
Measuring range from 0 ...		±2.5 N	±5 N	±10 N	±20 N	±50 N	±100 N	±200 N	±500 N	
Electrical termination										
Specifications		shielded, PTFE coated, 4 wire cable with bare ends for soldering, cable length 1.7 m, with standardization in cable 2.0 m, not drag chain suitable								
		-	Optional: shielded, TFE coated, 4 wire cable with bare ends for soldering, cable length 1.7 m, with standardization in cable 2.0 m, drag chain suitable							
Cable fastening		cable cover								
Bending protection		without					anti-kink protection			
Bending radius		≥ 6 mm rigidly laid; ≥ 20 mm moving;					≥ 8 mm rigidly laid; ≥ 30 mm moving			
Cable model		PTFE 1.9 mm, TPE 1.8-2.0 diameter								

8431/8432	-	6001	6002	6005	6010	6020	6050	6100	
Measuring range from 0 ...		±1 kN	±2 kN	±5 kN	±10 kN	±20 kN	±50 kN	±100 kN	
Electrical termination									
Specifications		shielded, PTFE coated, 4 wire cable with bare ends for soldering, cable length 1.7 m, with standardization in cable 2.0 m, not drag chain suitable							
		Optional: shielded, TFE coated, 4 wire cable with bare ends for soldering, cable length 1.7 m, with standardization in cable 2.0 m, drag chain suitable							
Cable fastening		cable cover							PG screwing mini M8
Bending protection		anti-kink protection							without
Bending radius		≥ 8 mm rigidly laid; ≥ 30 mm moving							≥ 6 mm rigidly laid; ≥ 20 mm moving
Cable model		PTFE 1.9 mm, TPE 1.8-2.0 diameter							PTFE 2.2 mm

Accessories

Adapter

If a sensor of the model 8431 or 8432 should be mounted on a plunger of a press, a centering and mounting adapter with a 10 H7 mounting hole is available.

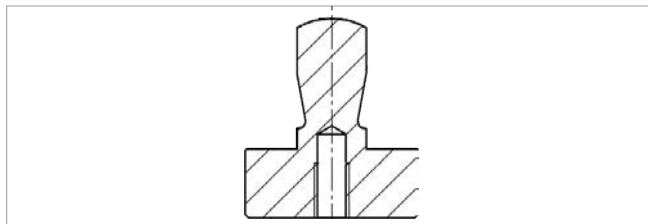

Order code

Article number	5501-Z014					5501-Z01			
Compatible for measuring range from 0 ...	±2.5 N	±5 N	±10 N	±20 N	±50 N	±100 N	±200 N	±500 N	
Centering and mounting adapter with internal thread	M4 x 0.7					M5 x 08			

Rod end bearings

- Optimal force introduction
- Compensation of misalignments
- Very high dynamic und static load capacity
- Material: stainless steel
- Temperature range: - 45 °C to + 120 °C
- PTFE insert, maintenance-free
- DIN 648 series K
- Bore holes H7, recommended connection pin: g6
- Inner ring not suitable for permanent rotary operation

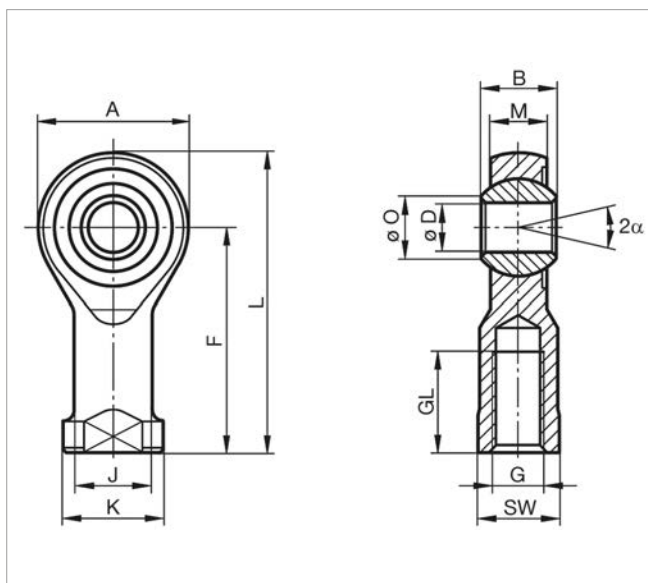

Order code

8591	-	Z04F	Z05F	Z06F	Z10F	Z12F
Compatible for measuring range from 0 ...		2.5 N ... 50 N	100 N ... 500 N	1 kN ... 5 kN	10 kN	20 kN
Geometry						
G	[mm]	M4 x 0.7	M5 x 08	M6 x 1.0	M10 x 1.5	M12 x 1.5
Ø D	[mm]	4	5	6	10	12
B	[mm]	7	8	9	14	16
M	[mm]	5.25	6	6.75	10.5	12
A	[mm]	16	18	20	29	32
F	[mm]	24	27	30	43	50
L	[mm]	31	36	40	57.5	66
K	[mm]	9.5	11	13	17	19
J	[mm]	7.8	9	10	15	17.5
Ø O	[mm]	6.5	7.7	8.9	12.9	15.4
SW	[mm]	8	9	11	19	19
GL	[mm]	10	10	12	20	22
α	[°]			13		
Other						
Stat. load factor	[kN]	4	11.8	16.7	28.3	34.5
Dyn. load factor	[kN]	2.3	7.5	9.3	23.4	32
Weight	[g]	11	18	27	76	115

Connectors and units

Order code

Connectors

9941	Connectors 12 pin, suitable to all burster desktop units
9900-V209	Connectors 9 pin, suitable to SENSORMASTER, DIGIFORCE® and TRANS CAL
9900-V229	Connectors 9 pin with TEDS
9900-V245	Connectors 8 pin, suitable to ForceMaster

Units

7281-V0001	Mobile measuring device with strain gage simulator and sensor test ($R_{i,r}$, $R_{o,r}$, Shunt, R_{ISO})
refer to section 9	Sensor electronics, amplifier and process control units like digital indicator model 9180, model 9163, modular amplifier model 9250 or DIGIFORCE®

Calibration

Test and calibration certificate

Supplied with the sensor	Amongst other data, includes figures for zero point, full-scale output and calibration offset
--------------------------	---

Standard factory calibration certificate for load cells or measurement chains (WKS)

Optionally available	Our standard factory calibration is performed in 20% steps starting from zero until the reaching the nominal force, for increasing and decreasing load with unchanged installation position. Factory calibration can be performed in compression and/or tension direction.
----------------------	--

Special factory calibration certificate for load cells or measurement chains (WKS)

On request	We are happy to calibrate sensors and measurement chains to the customer's specification.
------------	---

Calibration certificate with accreditation symbol for load cells of product group 8431/8432 for measuring ranges $\geq 0 \dots 20 \text{ N}$

Optionally available	Calibration certificate with accreditation symbol for load cells of product group 8431/8432. Calibration is performed on the basis of the accreditation of the calibration laboratory D-K-15141-01-00, for the scope of accreditation listed in the annex to the certificate. The traceability to national standards as well as a wide international recognition (DAkkS as signatory of the Multilateral Agreements of EA, ILAC and IAF) are thus guaranteed. Calibration is performed according to ISO 376 in 10 force steps (10% steps) vstarting from zero until the reaching the nominal force, for increasing and decreasing load under various installation positions.
----------------------	--



Order Code

Measuring range	Code	Measuring range
0 ... ±5 N*	5 0 0 5	0 ... ±1.24 lbs
0 ... ±10 N*/**	5 0 1 0	0 ... ±2.24 lbs
0 ... ±20 N*/**	5 0 2 0	0 ... ±4.49 lbs
0 ... ±50 N*/**	5 0 5 0	0 ... ±11.2 lbs
0 ... ±100 N*/**	5 1 0 0	0 ... ±22.5 lbs
0 ... ±200 N*/**	5 2 0 0	0 ... ±45.0 lbs
0 ... ±500 N*/**	5 5 0 0	0 ... ±112.4 lbs
0 ... ±1 kN*/**	6 0 0 1	0 ... ±225.0 lbs
0 ... ±2 kN*/**	6 0 0 2	0 ... ±450.0 lbs
0 ... ±5 kN**	6 0 0 5	0 ... ±1.1 klbs
0 ... ±10 kN**	6 0 1 0	0 ... ±2.2 klbs
0 ... ±20 kN**	6 0 2 0	0 ... ±4.5 klbs
0 ... ±50 kN**	6 0 5 0	0 ... ±11.2 klbs
0 ... ±100 kN**	6 1 0 0	0 ... ±22.5 klbs

* 8432 / ** 8431

										Delivery ex stock at short notice										
										N	0	0	0	S	0	0	0			
8	4	3	1	-																
8	4	3	2	-										S	0					
■ Nominal sensitivity/not standardized										N										
■ Standardization of sensitivity at 1.5 mV/V 8431 only for measuring ranges ≥ 0 ... 50 N 8432 only for measuring ranges ≥ 0 ... 20 N										E										
■ Connection cable 1.7 m (with standardization in the cable 2 m)										0										
■ Connection cable 3 m										F										
■ Connection cable 5 m										G										
■ Connection cable 3 m extended *										L										
■ Connection cable 5 m extended * (with sens line)										M										
* shortened delivery time compared with cable length 3 m and 5 m in one piece																				
■ Open cable ends + 6 cm single wires										0										
■ 9 pins Sub-D connector model 9900-V209										B										
■ 9 pins Sub-D connector model 9900-V209 for 9163-V3xxxx										E										
■ 12 pins round connector model 9941 for burster desktop devices										F										
■ 9 pins Sub-D connector with burster TEDS model 9900-V229										T										
■ 8 pins coupling connector model 9900-V245 for 9110										H										
■ Calibration and positive output signal for compression load										0										
■ Calibration and positive output signal for tension load										E										
■ Non-linearity according to specification										S										
■ Standard version																				0
■ Vacuum compatible (IP protection class low)																				1
■ Vibration protection																				3
■ Drag chain cable *																				4
■ Extended nominal temperature range -40 °C ... +90 °C																				A
■ Extended nominal temperature range -55 °C ... +120 °C																				B
■ Extended nominal temperature range +20 °C ... +120 °C																				C

Other special designs, such as higher temperature ranges or underwater cables on request.

* Options: Extended nominal temperature range not possible

MTS Messtechnik Schaffhausen GmbH

Mühlenstrasse 4, CH-8260 Stein am Rhein, Telefon +41 52-672 50 00, Telefax +41 52-672 50 01, www.mts.ch, e-mail: info@mts.ch

Messen Prüfen Automatisieren www.mts.ch

Order Code

Measuring range	Code	Measuring range
0 ... ±2.5 N (only 8432)*	2.5	0 ... ±1.22 lbs
0 ... ±5 N (only 8431)*	5	0 ... ±2.24 lbs

* only available with nominal sensitivity, 1.7 m connection cable length, various plugs without further options

8	4	3	1	-
8	4	3	2	-

