

# Precision Torque Sensor

rotating, contactless

## MODEL 8656



### Highlights

- Measurement ranges of 0 ... 1 N·m to 0 ... 100 N·m
- Very short design
- Output signal 0 ... ±10 V

### Options

- Speed and angle measurement with resolution of up to 400 increments
- USB port including software

### Applications

- End-of-line test benches
- Research & development
- Machinery and plant engineering
- Electric motor test
- Suitable for use in all types of test bench

**Highlight:**  
Very short design



Small measuring range

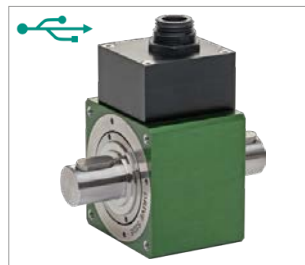

Large measuring range

### Product description

The very short torque sensor model 8656 is contactless constructed. The torque is recorded by the torsion of the shaft using the strain gauge principle. Thanks to the inductive and optical transmission of the signals, the sensor is maintenance-free, the signals are digitized directly on the shaft and made available by the evaluation electronics as a voltage signal or via USB. Thanks to the high-quality, up to 10,000 rpm is possible. The direction of rotation can be seen from the potential of the output voltage, clockwise rotation corresponds to positive output voltage, counterclockwise rotation the voltage level is negative.

The shaft is equipped with keyways in every measuring range, matching keys are included. If a key connection is not required, the key can be omitted. The torque is matched with suitable couplings, we recommend model 8690, safely transmitted.

To record the speed and angle of rotation, the sensor can optionally be equipped with an incremental disc with 400 increments. This speed / angle signal is available as a TTL output signal.

The free DigiVision software is available in connection with USB, alternatively drivers for LabVIEW and DASyLab are ready for download.

Connection cables in various lengths, metal bellows couplings and mounting brackets are available for integration in customer-specific systems.

## Technical Data

8656	-	5001	5002	5005	5010	5020	5050	5100
Measuring range calibrated in N·m from 0 ...		±1 N·m	±2 N·m	±5 N·m	±10 N·m	±20 N·m	±50 N·m	±100 N·m
<b>Accuracy</b>								
Relative non-linearity					0.2 % F.S.			
Relative hysteresis					0.15 % F.S.			
Tolerance of sensitivity					0.25 % F.S.			
<b>Electrical values</b>								
Rated supply voltage range		10 ... 30 V DC (or 5 V via USB)						
DC power consumption		approx. 2 W						
Output voltage at ± rated torque		±10 V						
Output resistance		330 Ω						
Insulation resistance		> 5 MΩ						
Update rate		400/sec.						
Ripple		< 50 mV <sub>ss</sub>						
Control signal		10.00 V DC						
<b>Environmental conditions</b>								
Range of operating and nominal temperature		0 °C ... +60 °C						
Sensitivity of temperature effects		on the zero point 0.015 % F.S./K on the sensitivity 0.015 % F.S./K						
<b>Mechanical values</b>								
Dynamic overload safe		recommended 70 % of nominal torque						
Max. operation torque		150 % of nominal torque						
Breakaway torque		300 % of nominal torque						
Alternating load		70 % of nominal torque						
Maximum limit axial load	[N]	70			150		165	
Maximum limit radial load	[N]	5	10	13	20	25	30	50
Spring constant	[N·m/rad]	330		1000		7500		18000
Mass moment of inertia measuring side	[10 <sup>-6</sup> kg·m <sup>2</sup> ]	4			8		22	
Mass moment of inertia drive side	[10 <sup>-6</sup> kg·m <sup>2</sup> ]	1			8.5		25	
Max. rotary speed	[min <sup>-1</sup> ]	10000						
<b>Other</b>								
Material		Housing: made of anodized aluminium; Shaft: steel shell 1.4542						
Protection class		acc. EN 60529, IP40						
Weight	[g]	310			485		710	
<b>Installation</b>								
Installation instructions		Do not exceed the permitted axial and radial forces during fitting and operation. Please refer to our operating instructions for detailed information <a href="http://www.burster.com">www.burster.com</a> . Suitable couplings should be used to avoid strain resulting from parallel or angular offset between the shafts.						



## Dimensional drawing

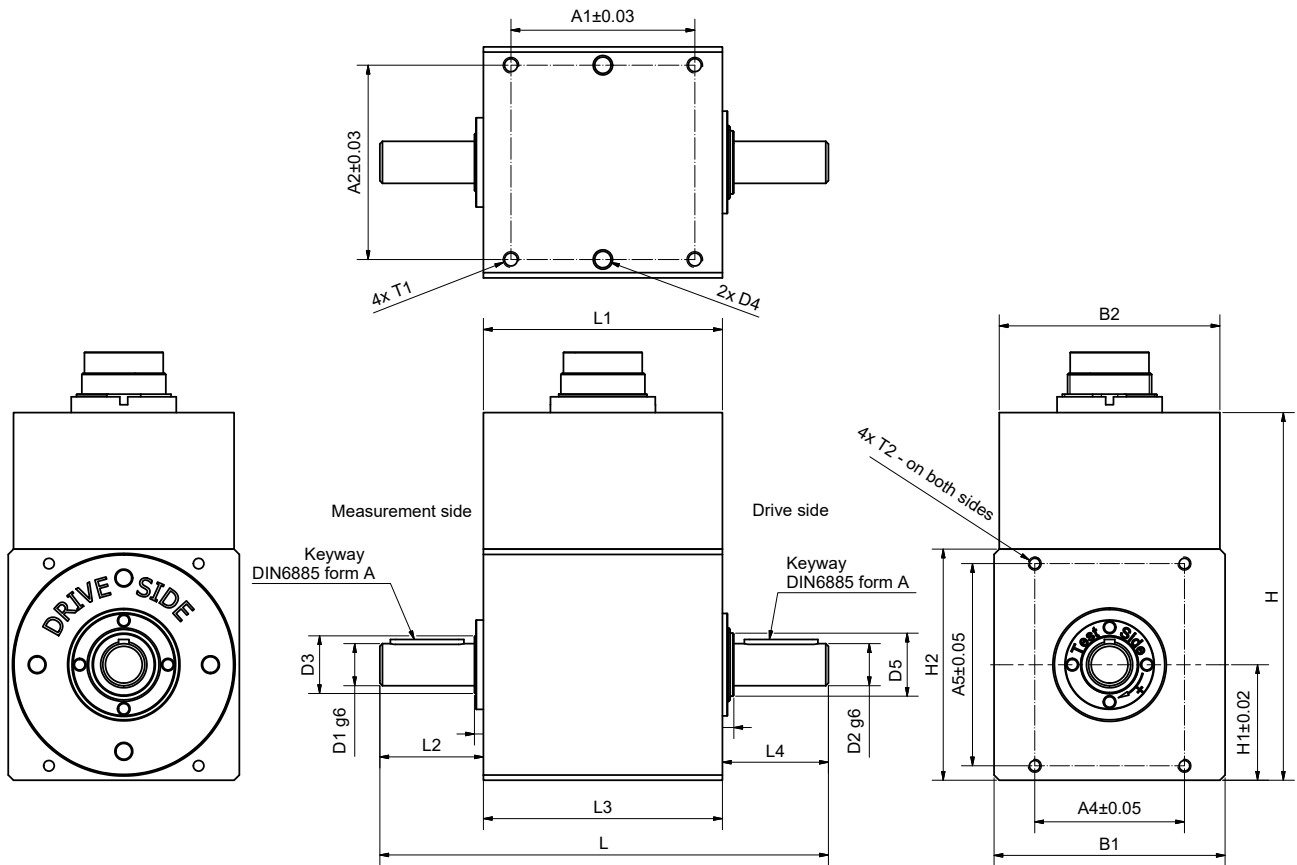

## Keyway:

Measuring range*	Form A
1 ... 10 N·m	2 x 2 x 14
20 ... 50 N·m	5 x 5 x 16
100 N·m	6 x 6 x 18

For detailed dimensions you can find sensor CAD data on our website [www.burster.com](http://www.burster.com).

8656	-	5001	5002	5005	5010	5020	5050	5100
Measuring range from 0 ...		±1 N·m	±2 N·m	±5 N·m	±10 N·m	±20 N·m	±50 N·m	±100 N·m
<b>Geometry</b>								
A1	[mm]	35						33.5
A2	[mm]		37			36		41
A4	[mm]		28.5			44		50
A5	[mm]		38.5			41		48
B1	[mm]		44			50		59
B2	[mm]		42					
D1 / D2	[mm]		8g6			15g6		18g6
D3	[mm]		11			16		24
D4 Ø / deep	[mm]		Ø 3.1 / 6					
H1	[mm]		22			25		29.5
H2	[mm]		44			50		59
L	[mm]		85.4			90.1		95.5
L2	[mm]		19.7			21.5		24
L3	[mm]		45.5			47.5		
L4	[mm]		20.2			21.1		24
T1 / deep	[mm]		M3 / 7			M4 / 7		
T2 / deep	[mm]		M2.5 / 8			M3 / 8		M4 / 8

## Electrical values

12-pin connector or mini USB with screw connection for configuration / measurement (option, USB connection cable included)

Wiring Code depends on the options selected		
Pin	Assignment	Cable colour (99540-000F-052XXXX)
A	NC	
B	Angular exit B	violet
C	Moment output +	yellow
D	Moment output -	green
E	Supply -	blue
F	Supply +	red
G	Angular exit A	pink
H	NC	
J	Ground angle output	black
K	Control signal	White
L	-	-
M	NC	

## Accessories

### Mounting block model 8600-Z02X



The mounting block has a central hole and special design allowing a range of options for reliable cable attachment. Two clips ensure the sensor is fixed securely.

For further information please see accessories data sheet 8600-Z02X

### Metal bellows couplings



Couplings are necessary for correct installation. We recommend torsionally free metal bellows couplings to achieve an optimum compensation of misalignment.

The couplings are characterized by their excellent torsional stiffness during torque load and their low restoring forces. The couplings are optionally available with feather keys.

For further information please see accessories data sheet 8690.

## Options

### Integrated amplifier with USB interface



This sensor version has an USB connection instead of the  $\pm 10$  V output. The sensor is powered via USB, no further connections required.

In addition to torque, the speed or rotation angle measured values are optionally available at the output. The mechanical performance calculated in the sensor is also displayed via the DigiVision software.

Free drivers are available for integration into LabVIEW and DASYlab, also a DLL for integration into your own programs.



## Torque sensor with integrated rotational speed / angular displacement measurement

8656 torque sensors are optionally available with integrated rotational speed and angular displacement measurement. Two pulse channels with TTL level – channel A and channel B – are always available. For clockwise rotation (looking at the test side), channel A leads channel B with a phase shift of  $90^\circ$ . Only one pulse channel is needed for speed measurement.

For angular displacement measurement (or direction detection), both channels need to be evaluated. To achieve the maximum angular resolution, four-edge decoding must be used to read both the rising and falling edges, so an angular resolution of  $0.255^\circ$  is possible.

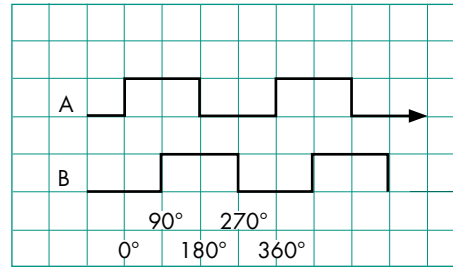

## DigiVision configuration and analysis software

### Features

- Can be used to actuate tare function
- Configuration options for averaging and filters
- Intuitive user interface
- Automatic sensor identification
- Sensor calibration data readout

DigiVision Light PC software	
freely available on our website	DigiVision configuration and analysis software max. 200 measured value/s for one sensor
DigiVision Standard PC software	
Model 8656-P100	DigiVision configuration and analysis software up to 16 channels
PC-Software DigiVision Professional	
Model 8656-P200	DigiVision configuration and analysis software with additional configurable maths channel; up to 32 channels

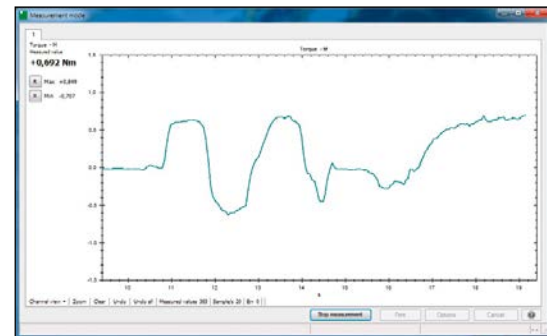

### USB measurement option

- Numerical & graphical display and measurement of the physical torque value
- Practical start and stop trigger functions
- 4 limits can be configured for each measurement channel
- MIN/MAX value acquisition
- Automatic scaling
- Measurement reports can be saved as Excel or PDF file
- Archive viewer for displaying sets of curves
- X Multichannel measurements, even with different sensors (e.g. 9206, 8631, 8625, 8661) available with standard version

## Accessories

Order code	
9940	Mating connection 12 pin (scope of delivery)
9900-V539	Mating connection 90°-angle
99540-000F-0520030	Connecting cable, length 3 m, other end free
99539-000F-0520030	Connecting cable, length 3 m, plug with 90°-angle, other end free
99209-540G-0160030	Connecting cable for model 7281 and model 9311, length 3 m, with external supply
99163-540A-0150030	Connecting cable, length 3 m, 8656 to DIGIFORCE® 9307 combined channel D (option channel)
99209-215A-0090004	Adapter cable to DIGIFORCE® 9307 standard channel A/B and C (usable only in connection with type 99163-540A-015xxxx)
	DigiVision Light configuration and analysis software, max. 200 measured value/s for one sensor (freely available on our website)
9900-K349	USB cable, length 2 m (included with the USB version)
8656-P100	DigiVision Standard configuration and analysis software; up to 16 channels
8656-P200	DigiVision Professional with additional configurable maths channel; up to 32 channels
8600-Z02X	Mounting block, see accessories data sheet 8656-Z02X

## Calibration

Manufacturer Calibration Certificate (WKS)	
	Special calibration for clockwise or/and counter clockwise direction torque, in 20 % steps of range up and down.
DAkkS Calibration Certificate	
	DAkkS calibration certificate per DIN 51309, clockwise or/and counter clockwise torque, with eight steps spaced across the measurement range, increasing and decreasing.

## Order Code

Measuring Range					Code									
0 ...	±1	N·m			5	0	0	1						
0 ...	±2	N·m			5	0	0	2						
0 ...	±5	N·m			5	0	0	5						
0 ...	±10	N·m			5	0	1	0						
0 ...	±20	N·m			5	0	2	0						
0 ...	±50	N·m			5	0	5	0						
0 ...	±100	N·m			5	1	0	0						
									Standard					
									0	0	0	2	0	
<b>8</b>	<b>6</b>	<b>5</b>	<b>6</b>	<b>-</b>					<b>-</b>	<b>V</b>	<b>0</b>		<b>2</b>	<b>0</b>
										0				
										1				
<b>Output signals</b>														
■ Output voltage 0 ... ±10 V										0				
■ USB interface										1				
■ Rounded shaft ends with keyway														2