

Low-Cost Tension and Compression Load Cell

MODEL 8427 **NEW**



Highlights

- Measuring ranges from 0 ... 20 N to 0 ... 10 kN
- Rugged welded construction
- Flange for easy assembly
- Excellent price/performance ratio

Options

- Also available with external thread
- Optional with burster TEDS or standardized sensitivity
- Range of fixing and force transmission options

Applications

- All areas of mechanical engineering
- Automated production plants
- Tensile force measuring in Bowden cables
- Measuring tractive forces of plug connections
- Test equipment for safety areas on rail vehicles



With external thread as option



Small measuring range



With rod end bearings as option



With load button as option

Product description

This low cost tension/compression load cell is an especially robust component, which can be easily integrated in a girder assembly between two cables or chains for measuring force. The standard model comes with internal thread, allowing any adapter parts, for instance eye brackets, to be fitted in the axis of symmetry. Alternatively, the optionally available adapters with external thread can be used for quick and easy screw-fitting into a threaded hole made for the purpose.

The radial connection cable is extremely flexible and designed for a wide range of motion. In order to achieve the greatest possible stability for such a small sensor, making it suitable not only for the laboratory but also for industrial use, all parts have been welded together including the cable guide bush in the sensor housing.

The measurement element is a membrane perpendicular to the axis of the sensor with a strain gage full bridge applied to the inner surface, which requires stable excitation with a rated value of approx. 1 mV/V.

burster TEDS with an electronic sensor datasheet or standardization of the output signal in the sensor connecting cable are offered as options.

Technical Data

8427	-	5020	5050	5100	5200	5500	6001	6002	6005	6010	
Measuring range calibrated in N and kN from 0 ...		±20 N	±50 N	±100 N	±200 N	±500 N	±1 kN	±2 kN	±5 kN	±10 kN	
		±4.5 lbs	±11.2 lbs	±22.5 lbs	±45.0 lbs	±112.4 lbs	±224.8 lbs	±449.6 lbs	±1.1 klbs	±2.2 klbs	
Accuracy											
Relative non-linearity*		0.5 % F.S.									
Characteristic curve deviation*		0.75 % F.S.									
Hysteresis		< 0.25 % F.S.									
Temperature effect on zero output		≤ 0.03 % F.S./K									
Temperature effect on nominal sensitivity		≤ 0.02 % F.S./K									
Electrical values											
Sensitivity		nominal: ca. 1,1 mV/V, positive output signal in compression direction									
Measurement direction		Tension and compression direction. Load calibration in compression direction. The full-scale output is likely to be different when used in the tension direction.									
Standardization		1.0 mV/V, option realized on an circuit board 48 x 7 mm (L x W) at the cable after 1.7 m from sensor or 0.3 m from cable end									
Bridge resistance		350 Ω nominal (deviations are possible)									
Excitation		5 V DC or AC									
Isolation resistor		> 30 MΩ									
Environmental conditions											
Nominal temperature range		+15 °C ... +70 °C									
Operating temperature range		-30 °C ... +80 °C									
Mechanical values											
Deflection full scale		< 60 μm									
Maximum operating force		150 % of capacity									
Overload burst		300 % of capacity									
Dynamic performance		recommended: 70 %: maximum: 100 % (of capacity)									
Material		stainless steel 1.4542									
Protection class (EN 60529)		IP65									
Geometry											
Central blind threaded hole T		M 4					M 10				
Number of clearing holes in Ø		3 * M3 - 5 deep									
Dimensional drawings		dimensional drawing 1					dimensional drawing 2				
Installation											
Torque counter nuts	[N*m]	2					20				
Tightening torque mounting screws	[N*m]	1.2									
Mounting screws		resistance 8.8 or higher									
Installation instructions		the entire bearing area of the sensor must be mounted on a base which is hardened (60 HRC). flat, polished or better lapped.									
Other											
Natural frequency	[kHz]	0.2	0.4	0.6	0.9	0.6	1	1.4	2	2.4	
Mass (without options/accessory)	[g]	95					550				

* The data in the area 20 % - 100 %



Dimensional drawing 1 – Measuring ranges from 0 ... ±20 N up to 0 ... ±200 N | from 0 ... ±4.5 lbs up to 0 ... ±45.0 lbs

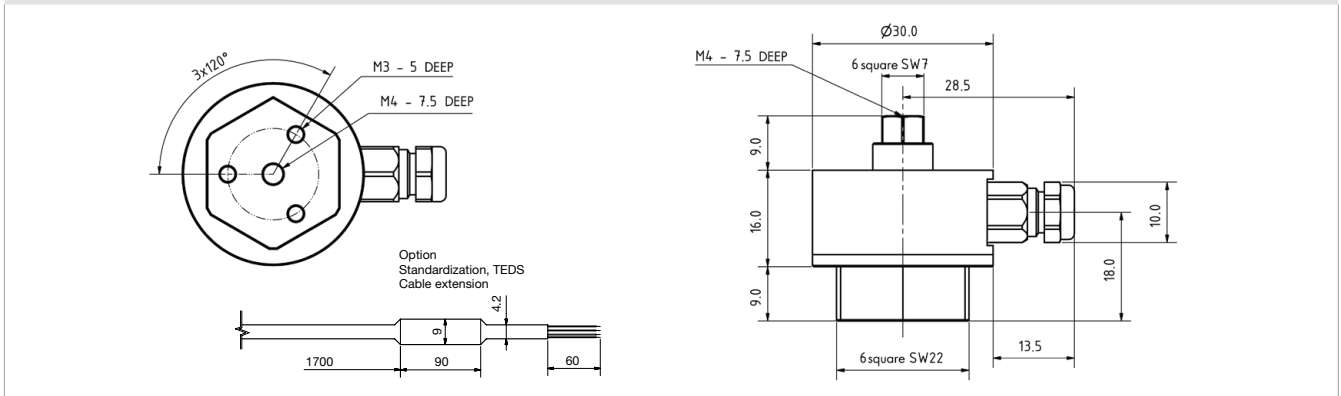

Dimensional drawing 2 – Measuring ranges from 0 ... ±500 N up to 0 ... 10 kN | from 0 ... ±112.4 lbs up to 0 ... ±2.2 klbs

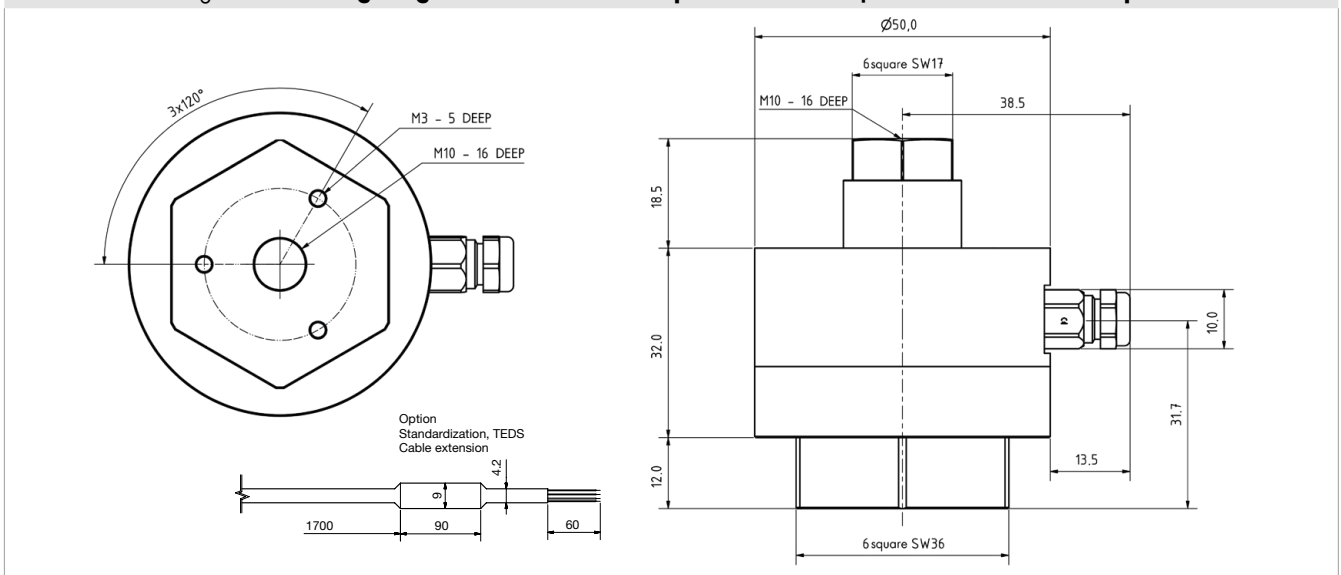

Electrical termination

Output signal

burster load cells are based on a strain-gage Wheatstone bridge. This measurement principle means that the output voltage mV/V is highly dependent on the sensor supply voltage. Our website contains details of suitable instrumentation amplifiers, indicator and display devices and process instruments.

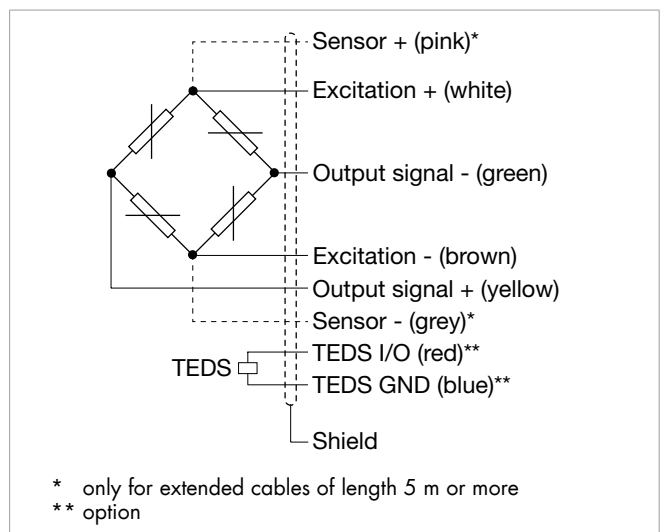

8427	-	5020	5050	5100	5200	5500	6001	6002	6005	6010
Measuring range from 0 ...		±20 N	±50 N	±100 N	±200 N	±500 N	±1 kN	±2 kN	±5 kN	±10 kN
Electrical termination										
Cabel specifications		Highly flexible, shielded, drag chains suitable. Bending radius three times the diameter for fixed cable, ten times the diameter for cable permanently moving, length 1,7 m, open ends with end ferrules, cable output Mini PG M6 x 1								
Cable model		4 wire TPE isolated shielded control lines, ø d = 3 mm								

Accessories

Load application adapters

Numerous load application adapters are optionally available, giving the user a wide choice of mechanical designs for load application. The threaded adapters have a domed top surface.

Note: Whether using an internal or external thread (sensor or additional adapters), the associated thread is designed to be long enough for a rod end bearing to DIN 680-K (with internal or external thread) and a locknut to DIN 934.

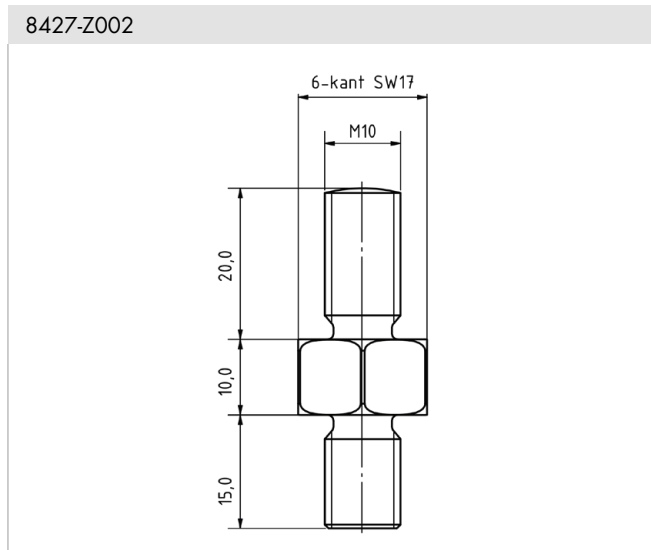
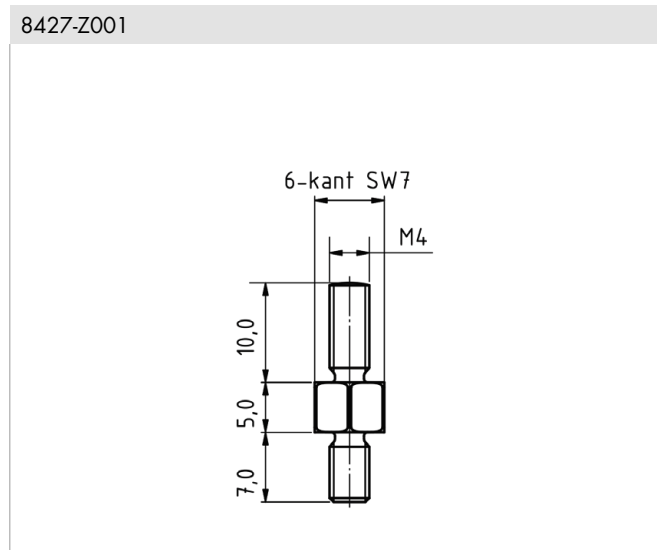

Order Code

8427	-	Z001				Z002				
Compatible for measuring range from 0 ...		±20 N	±50 N	±100 N	±200 N	±500 N	±1 kN	±2 kN	±5 kN	±10 kN
Installation										
Tightening torque thread adapter	[N*m]	2				20				
Other										
Mass	[g]	50				400				

Rod end bearings

The 8427 load cell can be optionally supplied with one or two rod end bearings. Rod end bearings ensure optimum load application when the sensor is used in the tension direction. In addition, they can compensate for slight misalignment in the compression direction.

- Optimal force introduction
- Compensation of misalignments
- Very high dynamic and static load capacity
- Material: stainless steel
- Temperature range: - 45 °C to + 120 °C
- PTFE insert, maintenance-free
- DIN 648 series K
- Bore holes H7, recommended connection pin: g6
- Inner ring not suitable for permanent rotary operation

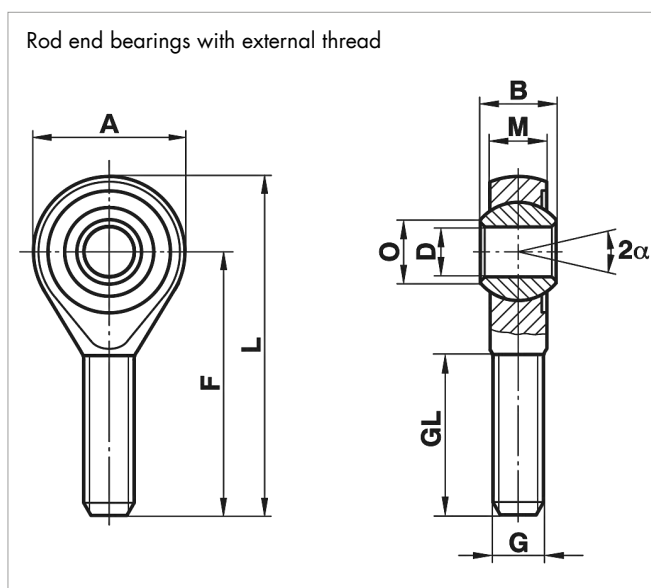

Order Code

8591	-	Z10M								
Compatible for measuring range from 0 ...		±20 N	±50 N	±100 N	±200 N	±500 N	±1 kN	±2 kN	±5 kN	±10 kN
Geometry										
B	[mm]	14								
M	[mm]	10.5								
A	[mm]	29								
F	[mm]	48								
L	[mm]	62.5								
O	[mm]	12.9								
D	[mm]	10								
G		M10 x 1.5								
GL	[mm]	29								
α	[°]	13								
Other										
Stat. load factor	[kN]	25.5								
Dyn. load factor	[kN]	23.4								
Weight	[g]	56								

Load buttons

Load buttons are used when purely compressive forces are meant to be applied to the load cell and when direct coupling to the surrounding mechanical structure via the central threaded hole in the sensor is not required/possible. The domed surface of the load button minimizes angle errors for loads applied at an angle of up to 3°. The compressive force must be applied to the button via a flat and hardened contact surface. The optimum hardness is 60 HRC or more.

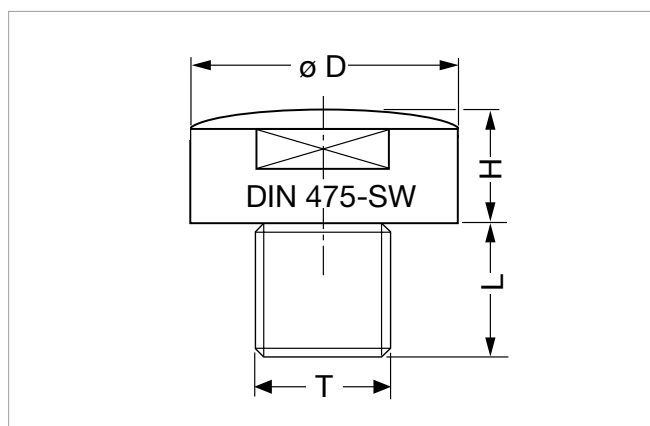
**Order Code**

8580	-	V004				V110				
Compatible for measuring range from 0 ...		±20 N	±50 N	±100 N	±200 N	±500 N	±1 kN	±2 kN	±5 kN	±10 kN
Geometry										
Ø D	[mm]	6.0				18.0				
H	[mm]	2.8				10.38				
L	[mm]	3.5				10.0				
T		M4				M10				
Installation										
Tightening torques thread adapter	[N*m]	2				20				
Other										
Mass	[g]	5				15				

Connectors and units

Order Code

Connectors		
9941		Connectors 12 pin, suitable to all burster desktop units
9900-V209		Connectors 9 pin, suitable to SENSORMASTER, DIGIFORCE® and TRANS CAL
9900-V229		Connectors 9 pin with TEDS
9900-V245		Connectors 8 pin, suitable to ForceMaster
Units		
7281-V0001		Mobile measuring device with strain gage simulator and sensor test (R_{it} , R_{at} , Shunt, R_{ISO})
refer to section 9		Sensor electronics, amplifier and process control units like digital indicator model 9180, model 9163, modular amplifier model 9250 or DIGIFORCE® model 9307

Calibration

Test and calibration certificate		
Supplied with the sensor		Amongst other data, includes figures for zero point, full-scale output and calibration offset
Standard factory calibration certificate for load cells or measurement chains (WKS)		
Optionally available		Our standard factory calibration certificate includes 11 measurement points, starting at zero, spread evenly in 20% steps over the full measuring range, for increasing and decreasing load under the same installation conditions. Factory calibrations can be performed in the compression and/or tension direction depending on the sensor type.
Special factory calibration certificate for load cells or measurement chains (WKS)		
On request		We are happy to calibrate sensors and measurement chains to the customer's specification.
German-accredited DAkkS calibration certificate for sensors and measurement chains (DKD)		
Optionally available		Our DAkkS-certified calibration laboratory provides calibration certificates to DIN EN ISO 376. The calibration certificate includes 21 measurement points, starting at zero, spread evenly in 10% steps over the measuring range, for increasing and decreasing load under various installation conditions. DAkkS calibrations can be performed in the compression and/or tension direction depending on the sensor type.



Order Code

Measuring range	Code				Measuring range
0 ... ±20 N	5	0	2	0	0 ... ±4.5 lbs
0 ... ±50 N	5	0	5	0	0 ... ±11.2 lbs
0 ... ±100 N	5	1	0	0	0 ... ±22.5 lbs
0 ... ±200 N	5	2	0	0	0 ... ±45.0 lbs
0 ... ±500 N	5	5	0	0	0 ... ±112.4 lbs
0 ... ±1 kN	6	0	0	1	0 ... ±224.8 lbs
0 ... ±2 kN	6	0	0	2	0 ... ±449.6 lbs
0 ... ±5 kN	6	0	0	5	0 ... ±1.1 klbs
0 ... ±10 kN	6	0	1	0	0 ... ±2.2 klbs

										Delivery ex stock at short notice								
										N	0	0	0	S	0	0	0	
8	4	2	7	-					-				0	S	0	0	0	
■ Nominal sensitivity/not standardized										N								
■ Standardization at 1,0 mV/V										C								
■ Connection cable 1.7 m (Standardization 2 m)										0								
■ Connection cable 3 m										F								
■ Connection cable 5 m										G								
■ Connection cable 3 m, extended by a circuit board at 1,7 m *										L								
■ Connection cable 5 m, extended by a circuit board at 1,7 m * (with sens line)										M								
* shortened delivery time compared with cable length 3 m and 5 m in one piece																		
■ Open cable ends + 6 cm single wires										0								
■ 9 pins Sub-D connector model 9900-V209										B								
■ 9 pins Sub-D connector model 9900-V209 for 9163-V3xxxx										E								
■ 12 pins round connector model 9941 for burster desktop devices										F								
■ 9 pins Sub-D connector with burster TEDS model 9900-V229										T								
■ 8 pins coupling connector model 9900-V245 for 9110										H								
■ Non-linearity according to data sheet														S				
■ Nominal temperature range +15 °C ... +70 °C																		0

