

Operator's Manual



optris[®] CT

LT/ LTF/ LTH/ 1M/ 2M/ 3M/ G5/ P3/ P7

Infrared-thermometer



MTS Messtechnik Schaffhausen GmbH

Mühlenstrasse 4, CH-8260 Stein am Rhein Telefon
+41 52-672 50 00
Telefax +41 52-672 50 01
www.mts.ch, e-mail: info@mts.ch

Messen Prüfen Automatisieren www.mts.ch



Table of Contents

Table of Contents	3
1 General Information	7
1.1 Description	7
1.2 Warranty	8
1.3 Scope of Supply	8
1.4 Maintenance	9
1.5 Model Overview.....	10
1.6 Factory Default Settings	12
2 Technical Data.....	14
2.1 General Specifications	14
2.2 Electrical Specifications.....	15
2.3 Measurement Specifications [LT models]	16
2.4 Measurement Specifications [CTfast/ CThot].....	17

2.5	Measurement Specifications [1M/ 2M/ 3M models]	19
2.6	Measurement Specifications [G5/ P7 models]	22
2.7	Optical Charts	23
2.8	CF Lens and Protective Window	34
3	Mechanical Installation	38
3.1	Mounting Accessories	41
3.2	Air Purge Collars	43
3.3	Further Accessories	45
4	Electrical Installation	52
4.1	Cable Connections	52
4.2	Ground Connection	55
4.2.1	1M, 2M, 3M models	55
4.2.2	LT, LTF, LTH, G5, P3, P7 models	56
4.3	Exchange of the Sensing Head	57

5	Outputs and Inputs	59
5.1	Analog Outputs.....	59
5.2	Digital Interfaces.....	60
5.3	Relay Outputs.....	60
5.4	Functional Inputs	61
5.5	Alarms	62
6	Operating	64
6.1	Sensor Setup.....	64
6.2	Error messages	70
7	IRmobile app.....	71
8	Software CompactConnect	73
8.1	Installation	73
8.2	Communication Settings	74
9	Basics of Infrared Thermometry.....	77

10 Emissivity	78
10.1 Definition.....	78
10.2 Determination of unknown Emissivity	78
10.3 Characteristic Emissivity	79
Appendix A – Table of Emissivity for metals.....	80
Appendix B – Table of Emissivity for non-metals.....	82
Appendix C – Smart Averaging.....	83
Appendix D – Declaration of Conformity	84

1 General Information

1.1 Description

Thank you for choosing the **optris® CT** infrared thermometer.

The sensors of the optris CT series are noncontact infrared temperature sensors.

They calculate the surface temperature based on the emitted infrared energy of objects [**► 9 Basics of Infrared Thermometry**]. The sensor housing of the CT head is made of stainless steel (IP65/ NEMA-4 rating) – the sensor electronics is placed in a separate box made of die casting zinc.



The CT sensing head is a sensitive optical system. Please use only the thread for mechanical installation.



- Avoid abrupt changes of the ambient temperature.
- Avoid mechanical violence on the head – this may destroy the system (expiry of warranty).
- If you have any problems or questions, please contact our service department.



Read the manual carefully before the initial start-up. The producer reserves the right to change the herein described specifications in case of technical advance of the product.



► All accessories can be ordered according to the referred part numbers in brackets [].

1.2 Warranty

Each single product passes through a quality process. Nevertheless, if failures occur please contact the customer service at once. The warranty period covers 24 months starting on the delivery date. After the warranty is expired the manufacturer guarantees additional 6 months warranty for all repaired or substituted product components. Warranty does not apply to damages, which result from misuse or neglect. The warranty also expires if you open the product. The manufacturer is not liable for consequential damage or in case of a non-intended use of the product.

If a failure occurs during the warranty period the product will be replaced, calibrated or repaired without further charges. The freight costs will be paid by the sender. The manufacturer reserves the right to exchange components of the product instead of repairing it. If the failure results from misuse or neglect the user has to pay for the repair. In that case you may ask for a cost estimate beforehand.

1.3 Scope of Supply

- CT sensing head with connection cable and electronic box
- Mounting nut
- Operators manual

1.4 Maintenance

Lens cleaning: Blow off loose particles using clean compressed air. The lens surface can be cleaned with a soft, humid tissue (moistened with water) or a lens cleaner (e.g. Purosol or B+W Lens Cleaner).



Never use cleaning compounds which contain solvents (neither for the lens nor for the housing).

1.5 Model Overview

The sensors of the CT series are available in the following basic versions:

Model	Model codes	Measurement range	Spectral response	Typical applications
CT LT	LT02	-50 to 600 °C	8-14 µm	non-metallic surfaces
	LT15			
	LT22	-50 to 975 °C		
CT fast	LT15F	-50 to 975 °C	8-14 µm	fast processes
	LT25F			
CT hot	LT02H	-40 to 975 °C	8-14 µm	high ambient temperatures (up to 250 °C)
	LT10H			
CT1M	1ML	485 to 1050 °C	1,0 µm	metals and ceramic surfaces
	1MH	650 to 1800 °C		
	1MH1	800 to 2200 °C		
CT 2M	2ML	250 to 800 °C	1,6 µm	metals and ceramic surfaces
	2MH	385 to 1600 °C		
	2MH1	490 to 2000 °C		

CT 3M	3ML	50 to 400 °C	2,3 µm	metals at low object temperatures (from 50 °C)
	3MH	100 to 600 °C		
	3MH1	150 to 1000 °C		
	3MH2	200 to 1500 °C		
	3MH3	250 to 1800 °C		
CT G5	G5L	100 to 1200 °C	5,0 µm	measurement of glass
	G5H	250 to 1650 °C		
CT P3	P3	50 to 400 °C	3,43 µm	temperatures of thin film plastics
CT P7	P7	0 to 710 °C	7,9 µm	

In the following chapters of this manual you will find only the short model codes.

On the 1M, 2M, 3M and G5 models the whole measurement range is split into several sub ranges (L, H, H1 etc.).

1.6 Factory Default Settings

The unit has the following presetting at time of delivery:

Signal output object temperature	0-5 V								
Emissivity	0,970 [LT/ G5/ P3/ P7] 1,000 [1M/ 2M/ 3M]								
Transmissivity	1,000								
Averaging (AVG)	0,2 s LT15F/ LT25F: 0,1 s 1M/ 2M/ 3M: 0,001 s								
Smart Averaging	inactive LT15F, LT25F, 1M, 2M, 3M: active								
Peak hold	inactive								
Valley hold	inactive								
	LT	1ML	1MH	1MH1	2ML	2MH	2MH1	3ML	3MH
Lower limit temperature range [°C]	0	485	650	800	250	385	490	50	100
Upper limit temperature range [°C]	500	1050	1800	2200	800	1600	2000	400	600
Lower alarm limit [°C] (normally closed)	30	600	800	1200	350	500	800	100	250
Upper alarm limit [°C] (normally open)	100	900	1400	1600	600	1200	1400	300	500

	3MH1	3MH2	3MH3	G5L	G5H	P3	P7		
Lower limit temperature range [°C]	150	200	250	100	250	50	0		
Upper limit temperature range [°C]	1000	1500	1800	1200	1650	400	710		
Lower alarm limit [°C] (normally closed)	350	550	750	200	350	70	30		
Upper alarm limit [°C] (normally open)	600	1000	1200	500	900	200	100		
Lower limit signal output	0 V								
Upper limit signal output	5 V								
Temperature unit	°C								
Ambient temperature compensation (Output at OUT-AMB as 0-5 V signal on LT, G5 and P7)	internal head temperature probe								
Baud rate [kBaud]	115								



Smart Averaging means a dynamic average adaptation at high signal edges.
[Activation via software only]. ► **Appendix C – Smart Averaging**

2 Technical Data

2.1 General Specifications

	Sensing head	Electronic box
Environmental rating	IP65 (NEMA-4)	IP65 (NEMA-4)
Operating Temperature	see: Measurement Specifications	-20...85 °C ¹⁾
Storage temperature	see: Measurement Specifications	-40...85 °C
Relative humidity	10...95 %, non-condensing	
Material	stainless steel	die casting zinc
Dimensions	28 mm x 14 mm or 32 mm x 14 mm, M12x1	89 mm x 70 mm x 30 mm
Dimensions CThot/ CT P3/ P7	55 mm x 29,5 mm, M18x1 (with massive housing)	
Weight	40 g	420 g
Weight CThot/ CT P3/ P7	205 g (with massive housing)	
Cable length	1 m (only LT02, LT15, LT22, CTfast) 3 m (Standard at CThot, 1M, 2M, 3M, G5, P3 and P7) ²⁾ 8 m 15 m	
Cable diameter	2,8 mm	
Ambient temperature cable	max. 180 °C [High temperature cable for CThot: 250 °C]	
Vibration	IEC 68-2-6: 3G, 11 – 200 Hz, any axis	
Shock	IEC 68-2-27: 50G, 11 ms, any axis	

Pressure resistance (head)	8 bar
Software (optional)	CompactConnect

¹⁾ The functionality of the LCD display can be limited at ambient temperatures below 0 °C

²⁾ The 3M models are only available with 3 m cable length

2.2 Electrical Specifications

Power Supply	8–36 VDC
Current draw	max. 100 mA
Outputs/ analog	
Channel 1	selectable: 0/ 4–20 mA, 0–5/ 10 V, thermocouple (J or K) or alarm output (Signal source: object temperature)
Channel 2 [LT/ G5/ P3/ P7 only]	Head temperature [-20...180 °C/ -20...250 °C on LT02H and LT10H] as 0–5 V or 0–10 V output or alarm output (Signal source switchable to object temperature or electronic box temperature if used as alarm output)
Alarm output	Open collector output (NPN type) at Pin AL2 [24 V/ 50 mA]
Output impedances	
mA	max. loop resistance 500 Ω (at 8-36 VDC)
mV	min. 100 KΩ load impedance
Thermocouple	20 Ω
Digital interfaces	USB, RS232, RS485, CAN, Profibus DP, Ethernet (optional plug-in modules)
Relay outputs	2 x 60 VDC/ 42 VAC _{RMS} , 0,4 A; optically isolated (optional plug-in module)

Functional inputs	<p>F1-F3; software programmable for the following functions:</p> <ul style="list-style-type: none"> • external emissivity adjustment • ambient temperature compensation • trigger (reset of hold functions) <p>Input impedance F2 and F3: 43 kΩ</p>
-------------------	--

2.3 Measurement Specifications [LT models]

	LT02	LT15	LT22
Temperature range (scalable)	-50...600 °C		-50...975 °C
Ambient temperature (head)	-20...130 °C	-20...180 °C	
Storage temperature (head)	-40...130 °C	-40...180 °C	
Spectral range	8...14 μm		
Optical resolution	2:1	15:1	22:1
System accuracy ^{1), 2)}	$\pm 1,0$ °C or $\pm 1,0$ % ³⁾		
Repeatability ¹⁾	$\pm 0,5$ °C or $\pm 0,5$ % ³⁾		
Temperature coefficient ⁵⁾	$\pm 0,05$ K/ K or $\pm 0,05$ %/ K (whichever is greater)		
Temperature resolution (NETD) ^{3), 4)}	0,1 K	0,05 K	
Response time (95 % signal)	150 ms		
Warm-up time	10 min		
Emissivity/ Gain	0,100...1,100 (adjustable via programming keys or software)		

Transmissivity	0,100...1,100 (adjustable via programming keys or software)
Interface (optional)	USB (programmable adapter)
Signal processing	Average, peak hold, valley hold (adjustable via programming keys or software)

- ¹⁾ at ambient temperature 23±5 °C; whichever is greater
- ²⁾ Accuracy for thermocouple output: ±2,5°C or ±1%
- ³⁾ at object temperatures >0 °C, ε = 1
- ⁴⁾ at time constant 200 ms and an object temperature of 25 °C
- ⁵⁾ for ambient temperatures (head) <18 °C and >28 °C



On the LT02 models the head cable must not be moved during the measurement.

2.4 Measurement Specifications [CTfast/ CThot]

	LT15F	LT25F	LT02H	LT10H
Temperature range (scalable)	-50...975 °C		-40...975 °C	
Ambient temperature (head)	-20...120 °C		-20...250 °C	
Storage temperature (head)	-40...120 °C		-40...250 °C	
Spectral range	8...14 μm			
Optical resolution	15:1	25:1	2:1	10:1
System accuracy ^{1), 2)}	±2°C or ±1% ³⁾		±1,5°C or ±1% ³⁾	
Repeatability ¹⁾	±0,75 °C or ±0,75 % ³⁾		±0,5 °C or ±0,5 % ³⁾	

	LT15F	LT25F	LT02H	LT10H
Temperature coefficient ⁵⁾	$\pm 0,05 \text{ K/ K}$ or $\pm 0,05 \text{ %/ K}$ (whichever is greater)			
Temperature resolution (NETD) ^{3), 4)}	0,2 K	0,4 K	0,25 K	
Response time (90 % signal)	9 ms	6 ms	100 ms	
Warm-up time	10 min			
Emissivity/ Gain	0,100...1,100 (adjustable via programming keys or software)			
Transmissivity	0,100...1,100 (adjustable via programming keys or software)			
Signal processing	Average, peak hold, valley hold (adjustable via programming keys or software)			

¹⁾ at ambient temperature $23 \pm 5 \text{ }^\circ\text{C}$; whichever is greater

²⁾ Accuracy for thermocouple output: $\pm 2,5^\circ\text{C}$ or $\pm 1\%$

³⁾ at object temperatures $\geq 20 \text{ }^\circ\text{C}$

⁴⁾ at time constant 100 ms with smart averaging and an object temperature of $25 \text{ }^\circ\text{C}$

⁵⁾ for ambient temperatures (head) $< 18 \text{ }^\circ\text{C}$ and $> 28 \text{ }^\circ\text{C}$



On the CHot models [LT02H/ LT10H] the head cable must not be moved during the measurement.

2.5 Measurement Specifications [1M/ 2M/ 3M models]

	1ML	1MH	1MH1	2ML
Temperature range (scalable)	485...1050 °C	650...1800 °C	800...2200 °C	250...800 °C
Ambient temperature (head)	-20...100 °C			-20...125 °C
Storage temperature (head)	-40...100 °C			-40...125 °C
Spectral range	1,0 µm			1,6 µm
Optical resolution	40:1	75:1		40:1
System accuracy ¹⁾²⁾	±(0,3 % of reading +2°C) ³⁾			
Repeatability ¹⁾	±(0,1 % of reading +1 °C) ³⁾			
Temperature coefficient ⁵⁾	±0,05 K/ K or ±0,05 %/ K (whichever is greater)			
Temperature resolution (NETD)	0,1 K ³⁾			
Exposure time (90 % signal)	1 ms ⁴⁾			
Emissivity/ Gain	0,100...1,100 (adjustable via programming keys or software)			
Transmissivity	0,100...1,000 (adjustable via programming keys or software)			
Signal processing	Average, peak hold, valley hold (adjustable via programming keys or software)			

¹⁾ at ambient temperature 23±5 °C

²⁾ Accuracy for thermocouple output: ±3,5°C or ±1%

³⁾ ε = 1/ Response time 1s

⁴⁾ with dynamic adaptation at low signal levels

⁵⁾ for ambient temperatures (head) <18 °C and >28 °C

	2MH	2MH1	3ML	3MH
Temperature range (scalable)	385...1600 °C	490...2000 °C	50...400 °C ^{1), 2)}	100...600 °C ^{1), 2)}
Ambient temperature (head)	-20...125 °C		-20...85 °C	
Storage temperature (head)	-40...125 °C		-40...125 °C	
Spectral range	1,6 µm		2,3 µm	
Optical resolution	75:1		22:1	33:1
System accuracy ^{3) 4)}	±(0,3 % of reading +2°C) ⁵⁾			
Repeatability ³⁾	±(0,1 % of reading +1 °C) ⁵⁾			
Temperature coefficient ⁷⁾	±0,05 K/ K or ±0,05 %/ K (whichever is greater)			
Temperature resolution (NETD)	0,1 K ⁵⁾			
Exposure time (90 % signal)	1 ms ⁶⁾			
Emissivity/ Gain	0,100...1,100 (adjustable via programming keys or software)			
Transmissivity	0,100...1,000 (adjustable via programming keys or software)			
Signal processing	Average, peak hold, valley hold (adjustable via programming keys or software)			

¹⁾ $T_{\text{Object}} > T_{\text{Head}} + 25 \text{ °C}$

²⁾ Specification valid at $T_{\text{Object}} \geq \text{start of measurement range} + 50 \text{ °C}$

³⁾ at ambient temperature $23 \pm 5 \text{ °C}$

⁴⁾ Accuracy for thermocouple output: $\pm 2,5 \text{ °C}$ or $\pm 1\%$

⁵⁾ $\varepsilon = 1$ / Response time 1s

⁶⁾ with dynamic adaptation at low signal levels

⁷⁾ for ambient temperatures (head) $< 18 \text{ °C}$ and $> 28 \text{ °C}$

	3MH1	3MH2	3MH3
Temperature range (scalable) ²⁾	150...1000 °C	200...1500 °C	250...1800 °C
Ambient temperature (head)	-20...85 °C		
Storage temperature (head)	-40...125 °C		
Spectral range	2,3 µm		
Optical resolution	75:1		
System accuracy ¹⁾³⁾	±(0,3 % of reading +2°C) ⁴⁾		
Repeatability ¹⁾	±(0,1 % of reading +1 °C) ⁴⁾		
Temperature coefficient ⁶⁾	±0,05 K/ K or ±0,05 %/ K (whichever is greater)		
Temperature resolution (NETD)	0,1 K ⁴⁾		
Response time (90 % signal)	1 ms ⁵⁾		
Emissivity/ Gain	0,100...1,100 (adjustable via programming keys or software)		
Transmissivity	0,100...1,000 (adjustable via programming keys or software)		
Signal processing	Average, peak hold, valley hold (adjustable via programming keys or software)		

¹⁾ at ambient temperature 23±5 °C

²⁾ Specification valid at T_{Object} ≥ start of measurement range + 50°C

³⁾ Accuracy for thermocouple output: ±2,5°C or ±1%

⁴⁾ ε = 1/ Response time 1s

⁵⁾ with dynamic adaptation at low signal levels

⁶⁾ for ambient temperatures (head) <18 °C and >28 °C

2.6 Measurement Specifications [G5/ P7 models]

	G5L	G5H	P3	P7
Temperature range (scalable)	100...1200 °C	250...1650 °C	50...400 °C	0...710 °C
Ambient temperature (head)	-20...85 °C		0...75 °C	-20...85 °C
Storage temperature (head)	-40...85 °C			
Spectral range	5,0 μm		3,43 μm	7,9 μm
Optical resolution	10:1	20:1	15:1	10:1
System accuracy ¹⁾²⁾	±2 °C or ±1 % ³⁾		±3 °C or ±1 %	±1,5 °C or ±1 % ³⁾⁵⁾
Repeatability ¹⁾	±0,5 °C or ±0,5 % ³⁾		±1,5 °C	±0,5 °C or ±0,5 % ³⁾⁵⁾
Temperature coefficient ⁴⁾	±0,05 K/ K or ±0,05 %/ K (whichever is greater)			
Temperature resolution (NETD)	0,1 K ³⁾	0,2 K ³⁾	0,1 K ³⁾	0,5 K ³⁾
Response time (90 % signal)	120 ms	80 ms	100 ms	150 ms
Emissivity/ Gain	0,100...1,100 (adjustable via programming keys or software)			
Transmissivity	0,100...1,000 (adjustable via programming keys or software)			
Signal processing	Average, peak hold, valley hold (adjustable via programming keys or software)			

¹⁾ at ambient temperature 23±5 °C; whichever is greater

²⁾ Accuracy for thermocouple output: ±2,5°C or ±1%

³⁾ ε = 1/ Response time 1s

⁴⁾ for ambient temperatures (head) <18 °C and >28 °C

⁵⁾ at object temperatures ≥ 25 °C

2.7 Optical Charts

The following optical charts show the diameter of the measuring spot in dependence on the distance between measuring object and sensing head. The spot size refers to **90 % of the radiation energy**. The distance is always measured from the front edge of the sensing head.

As an alternative to the optical diagrams, the spot size calculator can also be used on the optris website <http://www.optris.com/spot-size-calculator>.



The size of the measuring object and the optical resolution of the infrared thermometer determine the maximum distance between sensing head and measuring object.

In order to prevent measuring errors the object should fill out the field of view of the optics completely.

Consequently, the spot should at all times have at least **the same size** like the object or should be **smaller than** that.

D = Distance from front of the sensing head to the object

S = Spot size

The D:S ratio is valid for the focus point.

LT25F

Optics: SF
D:S: 25:1

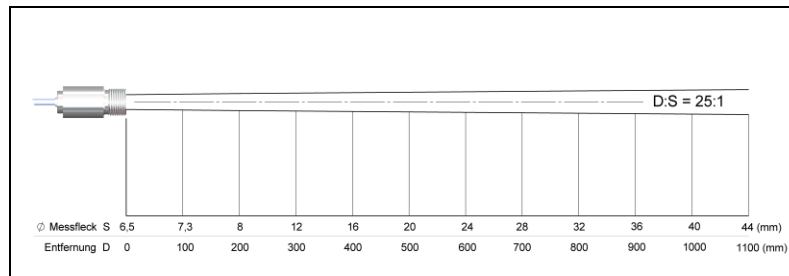
**LT22**

Optics: SF
D:S: 22:1

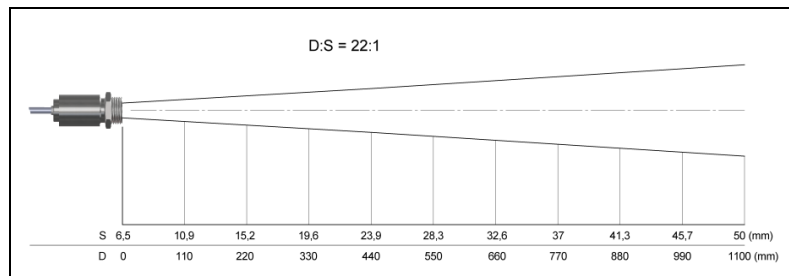
**LT22**

Optics: CF
D:S: 22:1
2,3mm@ 50mm
D:S (far field) = 6:1

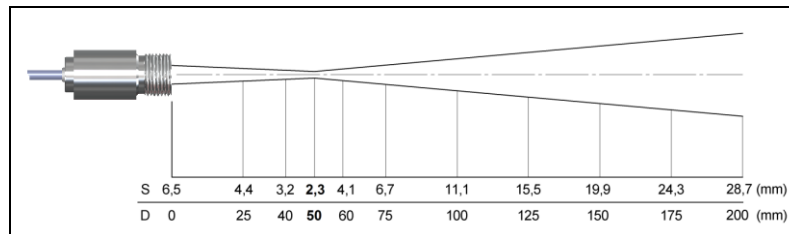

LT15 **LT15F**

Optics: SF
D:S: 15:1

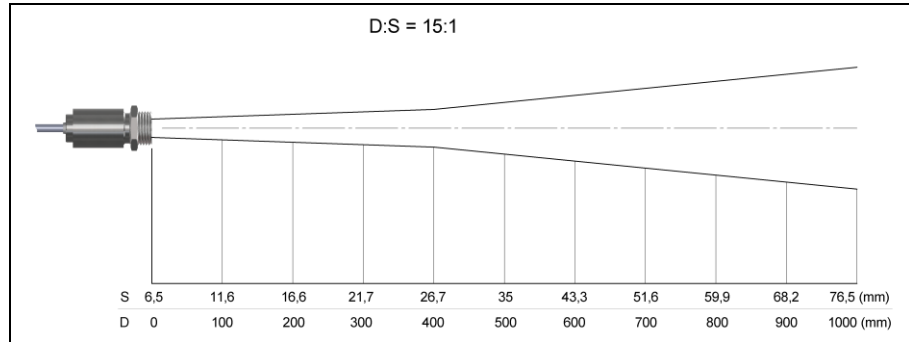

LT15 **LT15F**

Optics: CF
D:S: 15:1
3,0mm @ 50mm
D:S (far field) = 5:1

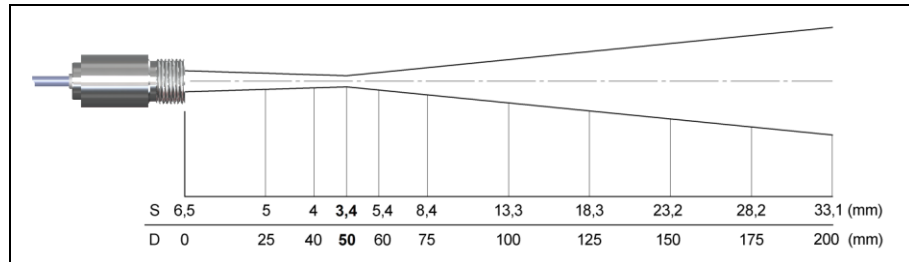

LT10H **G5L** **P7**

Optics: SF
D:S: 10:1

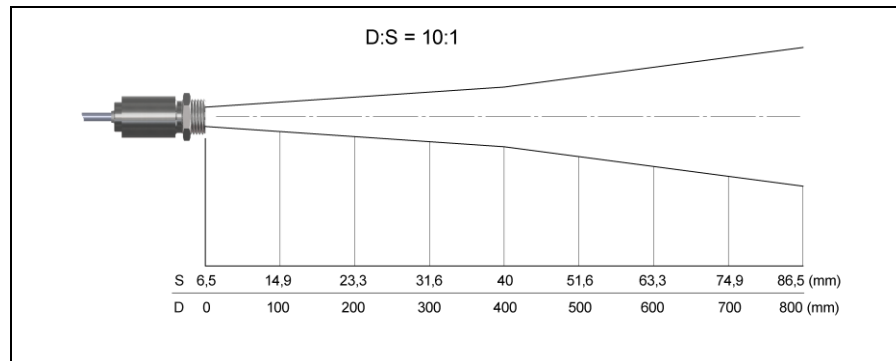

LT10H

Optics: CF1
D:S: 10:1
3,0mm @ 30mm
D:S (far field) = 3:1

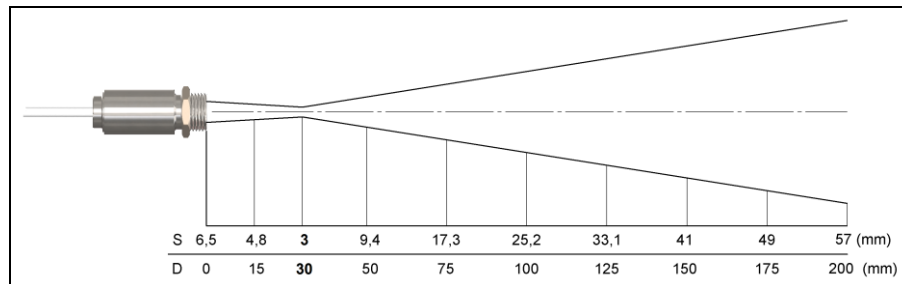

LT02 **LT02H**
Optics: SF
D:S: 2:1

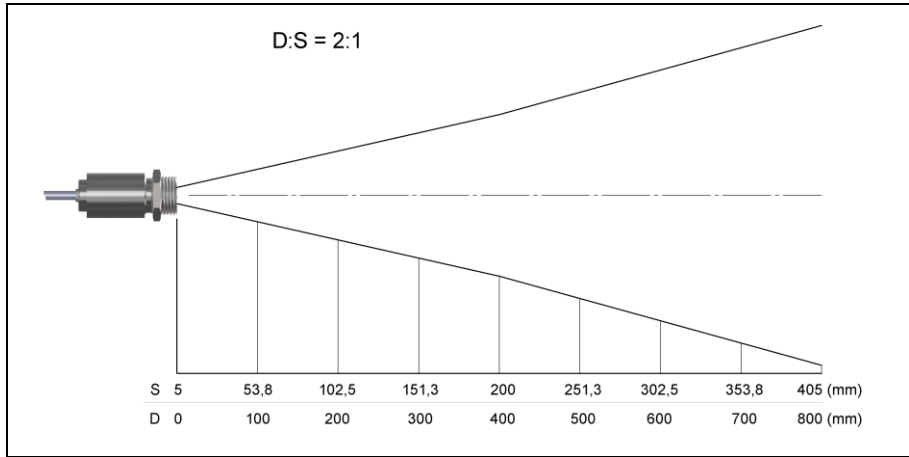

G5H
Optics: SF
D:S: 20:1

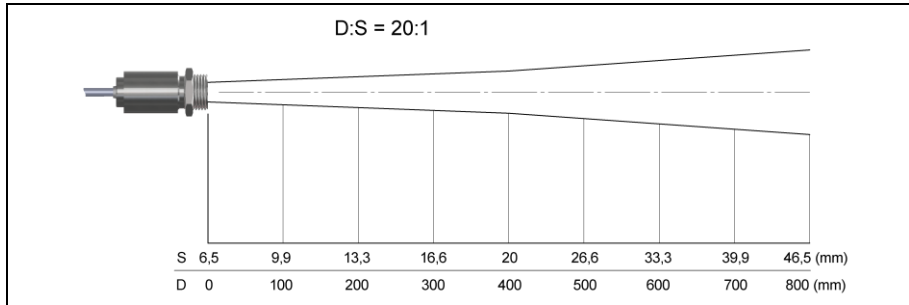

1ML **2ML**

Optics: CF
 D:S: 40:1
 2,7mm @ 110mm
 D:S (far field) = 12:1

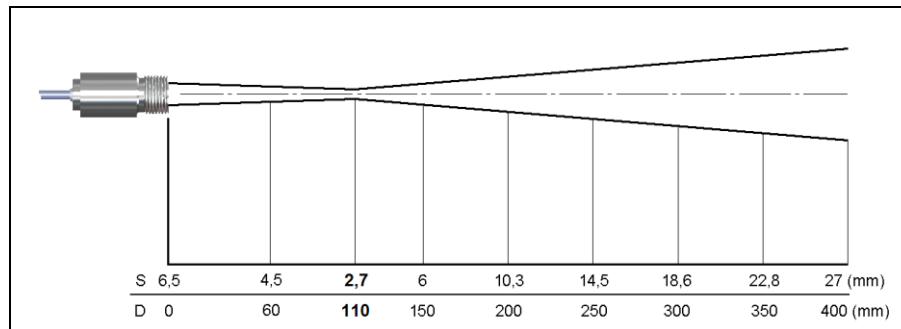

1ML **2ML**

Optics: SF
 D:S: 40:1

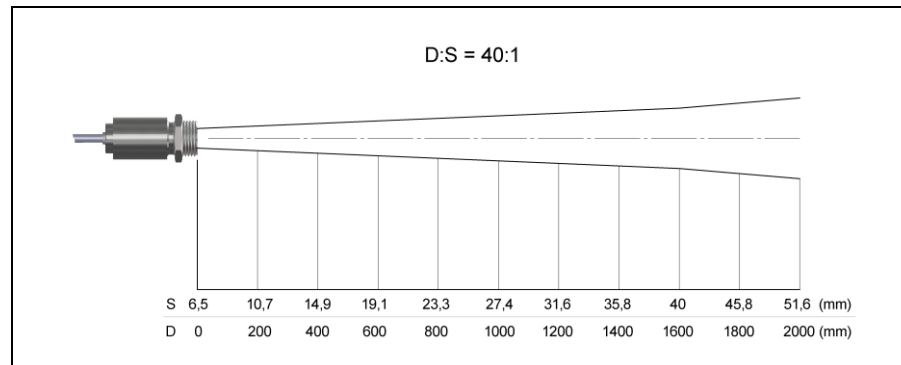

1MH **1MH1** **2MH**
2MH1 **3MH1-H3**
Optics: CF
D:S: 75:1
1,5mm@ 110mm
D:S (far field) = 14:1

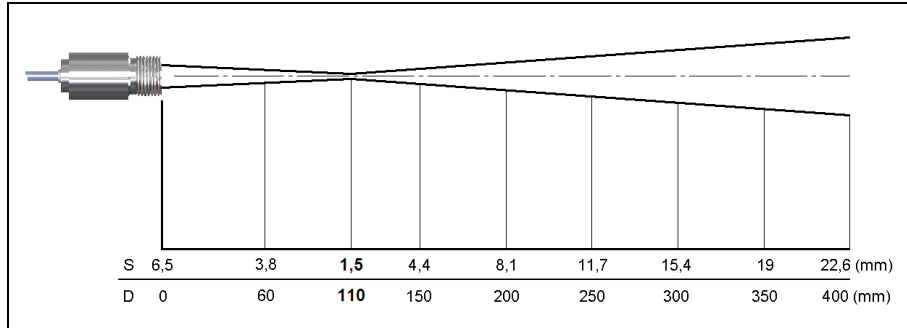

1MH **1MH1** **2MH**
2MH1 **3MH1-H3**
Optics: SF
D:S: 75:1

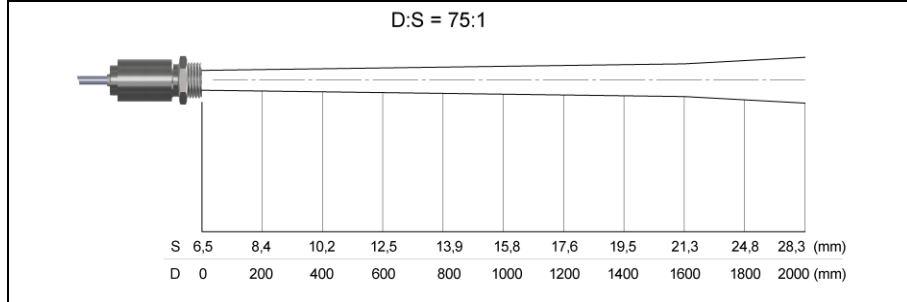

3ML

Optics: SF
D:S: 22:1

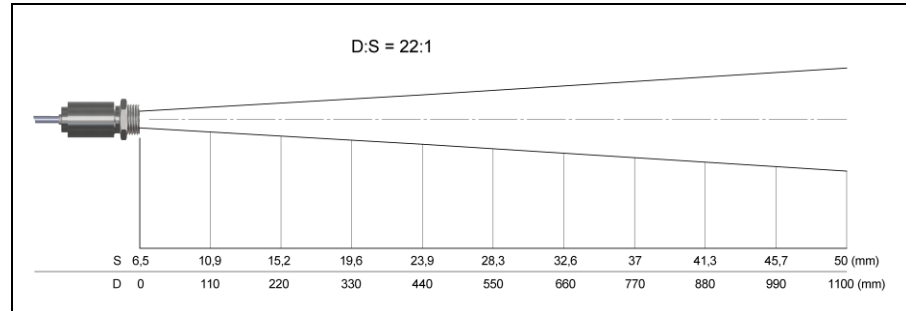
**3ML**

Optics: CF1
D:S: 22:1
1,5mm @ 30mm
D:S (far field) = 3,5:1

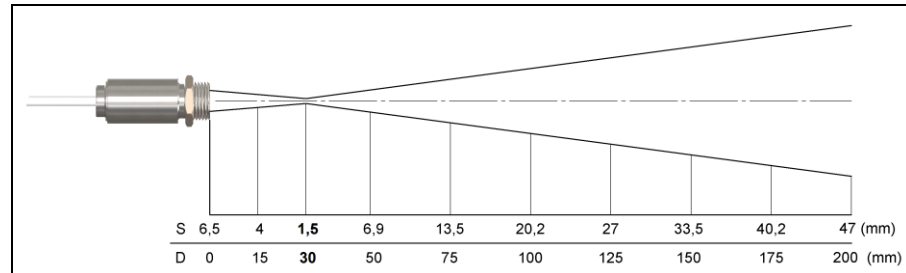

3ML

Optics: CF
 D:S: 22:1
 5mm@ 110mm
 D:S (far field) = 9:1

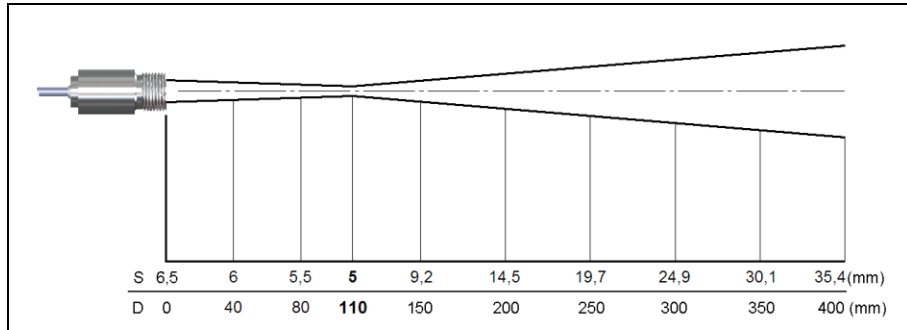

3MH

Optics: SF
 D:S: 33:1

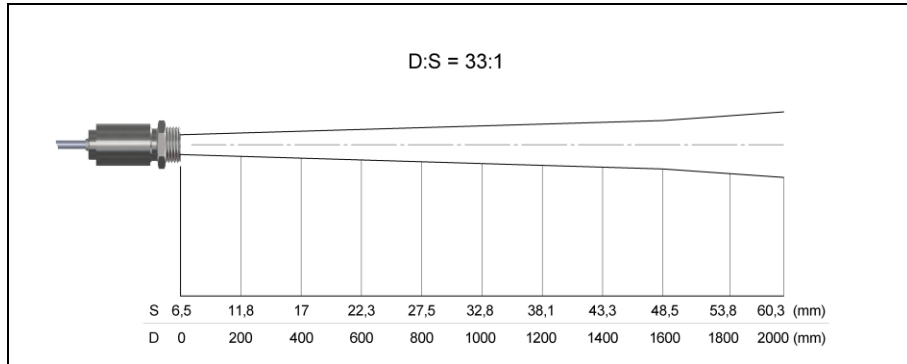

3MH

Optics: CF1
 D:S: 33:1
 1,0mm@ 30mm
 D:S (far field) = 4:1

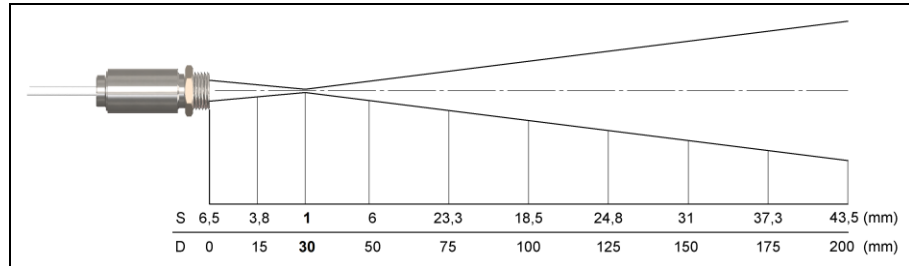
**3MH**

Optics: CF
 D:S: 33:1
 3,4mm@ 110mm
 D:S (far field) = 11:1

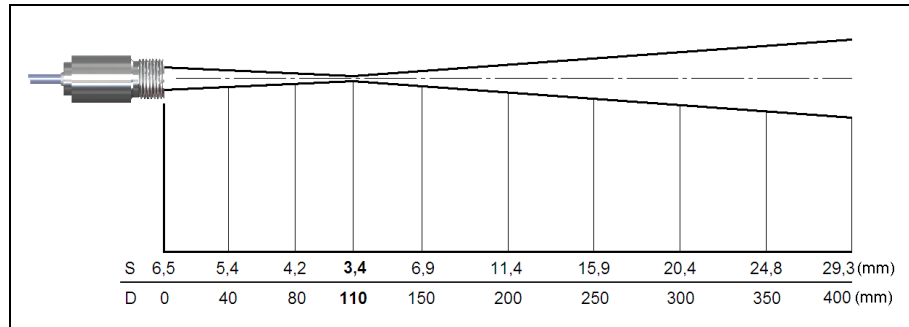

P3

Optik: SF
D:S: 15:1

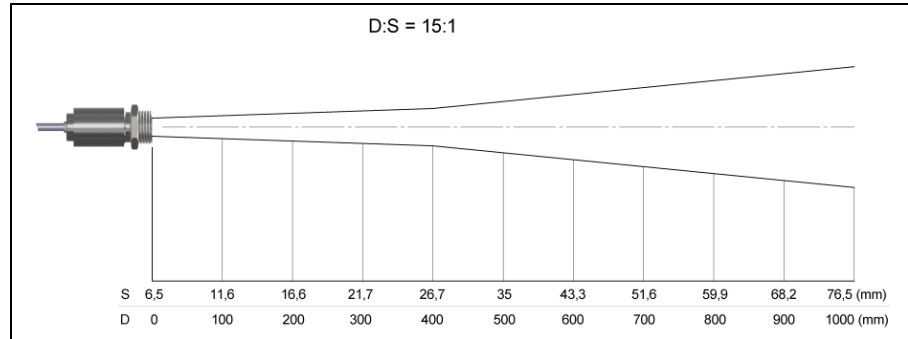

2.8 CF Lens and Protective Window

The optional CF lens allows the measurement of very small objects and can be used in combination with all LT, 1M, 2M and 3M models. The minimum spot size depends on the used sensing head. The distance is always measured from the front edge of the CF lens holder or laminar air purge collar. The installation on the sensing head will be done by turning the CF lens until end stop. To combine it with the massive housing please use the version with external thread M12x1.

Typical Transmission values* if the CF lens is used (average values):

LT	0,78
1M	0,80
2M	0,87
3M	0,92

*deviations possible

Versions Overview:

ACCTCF	CF lens for installation on sensing head [LT]
ACCTCFHT	CF lens for installation on sensing head [1M/ 2M/ 3M]
ACCTCFE	CF lens with external thread for installation in massive housing [LT]
ACCTCFHTE	CF lens with external thread for installation in massive housing [1M/ 2M/ 3M]

For protection of the sensing head optics a protective window is available. The mechanical dimensions are equal to the CF lens. It is available in the following versions:

ACCTPW	Protective window for installation on sensing head [LT]
ACCTPWHT	Protective window for installation on sensing head [1M/ 2M/ 3M]
ACCTPWE	Protective window with external thread for installation in the massive housing [LT]
ACCTPWHTTE	Protective window with external thread for installation in the massive housing [1M/ 2M/ 3M]

Typical Transmission values* if the protective window is used (average values):

LT	0,83
1M/ 2M/ 3M	0,93

*deviations possible

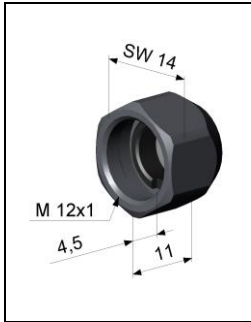

CF lens:
ACCTCF/ ACCTCFHT
Protective window:
ACCTPW/ ACCTPWHT

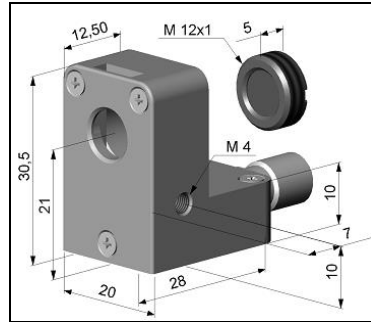

Laminar air purge with integrated CF lens:
ACCTAPLCF/ ACCTAPLCFHT

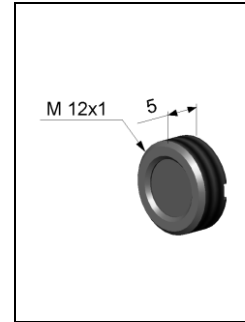

CF lens with external thread:
ACCTCFE/ ACCTCFHTE
Protective window with external thread:
ACCTPWE/ ACCTPWHT

LT25F + CF lens
 0,5 mm @ 8 mm
 0,5 mm @ 6 mm [ACCTAPLCF]
 D:S (far field) = 1,6:1

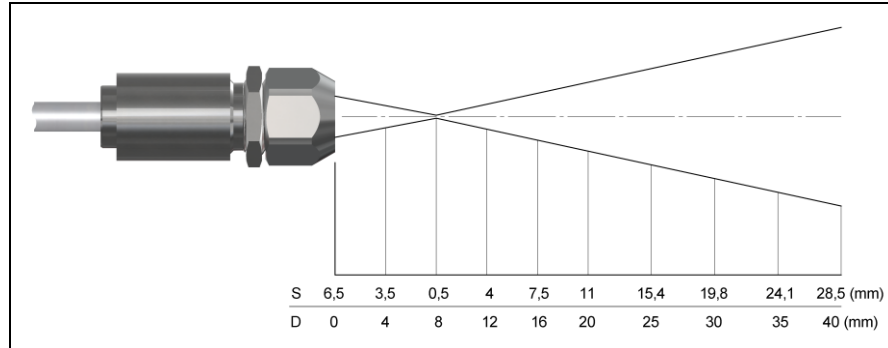

LT22 + CF lens

0,6 mm@ 10 mm

0,6 mm@ 8 mm [ACCTAPLCF]

D:S (far field) = 1,5:1

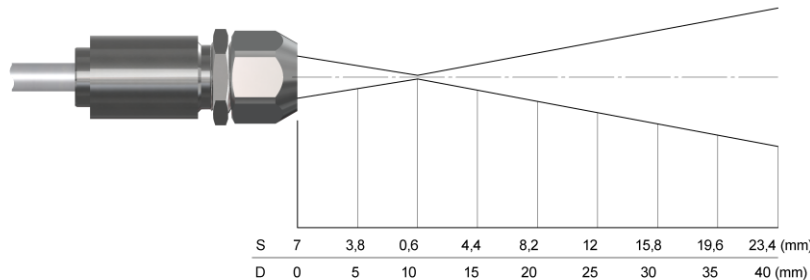
**LT15/ LT15F + CF lens**

0,8 mm@ 10 mm

0,8 mm@ 8 mm [ACCTAPLCF]

D:S (far field) = 1,5:1

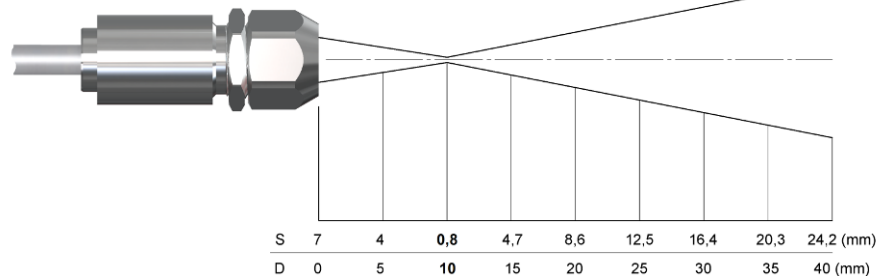

LT10H + CF lens

1,2 mm@ 10 mm

1,2 mm@ 8 mm [ACCTAPLCF]

D:S (far field) = 1,2:1

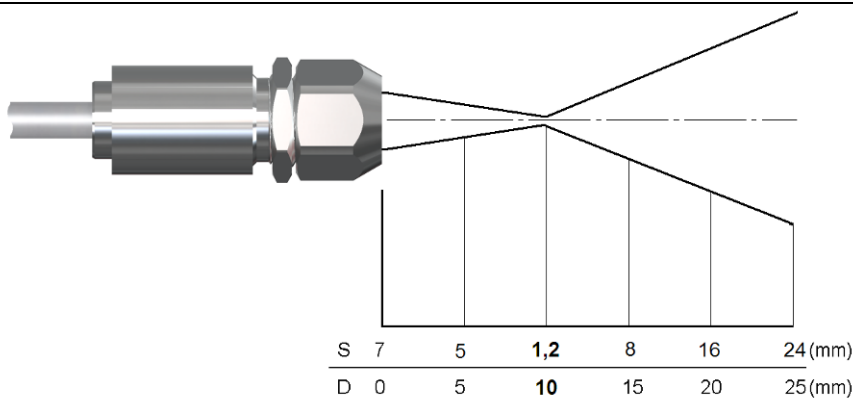

LT02/ LT02H + CF lens

2,5 mm@ 23 mm

2,5 mm@ 21 mm [ACCTAPLCF]

D:S (far field) = 2,5:1

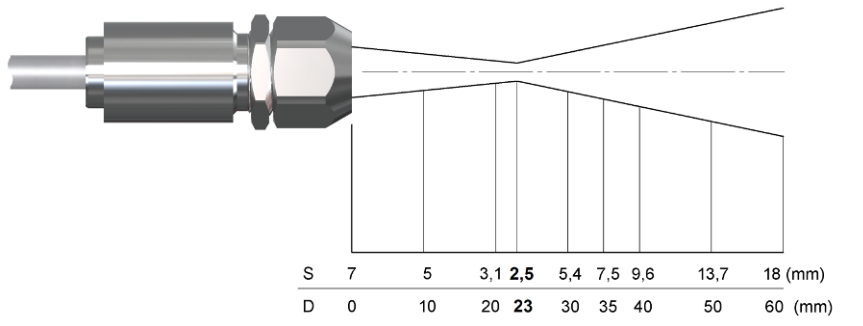

3 Mechanical Installation

The CT sensing heads are equipped with a metrical M12x1-thread and can be installed either directly via the sensor thread or with help of the hex nut (included in scope of supply) to the mounting bracket available. Various mounting brackets, which make the adjustment of the sensing head easier, can be additionally ordered as accessories.



All accessories can be ordered using the according part numbers in brackets [].

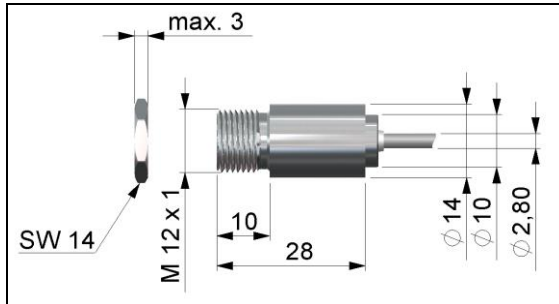

Sensing head

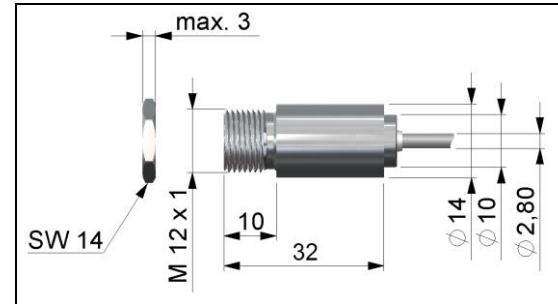

Sensing head LT15CF/ LT22CF/ 3MCF/ CTP7CF

The CThot- and CTP3/ P7-sensors will be delivered with the massive housing and can be installed via the M18x1-thread.

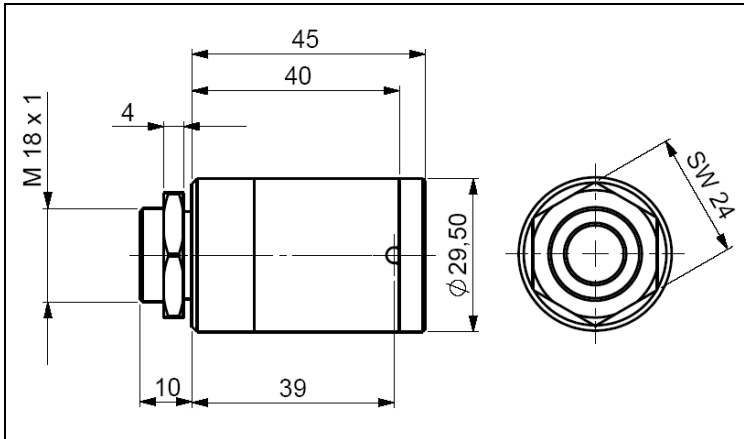

Massive housing (Standard on CThot, P3 and P7)



Make sure to keep the optical path clear of any obstacles.

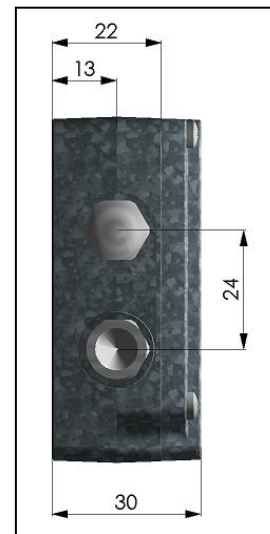
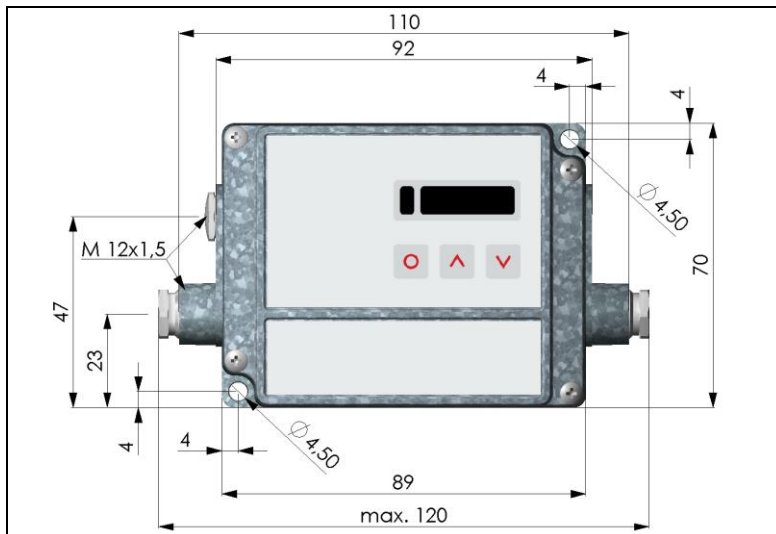

Electronic box

The electronic box is also available with closed cover (display and programming keys with no access from outside) [ACCTCOV].

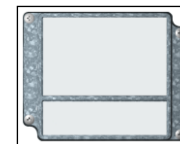

On the CT models LT02, LT02H and LT10H the head cable must not be moved during the measurement.

3.1 Mounting Accessories

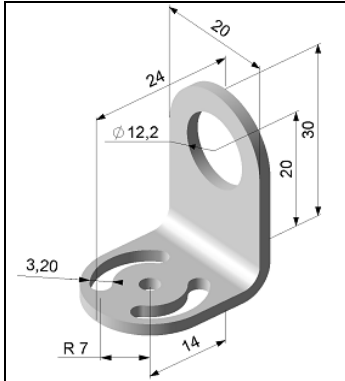

Mounting bracket, adjustable in one axis [ACCTFB]

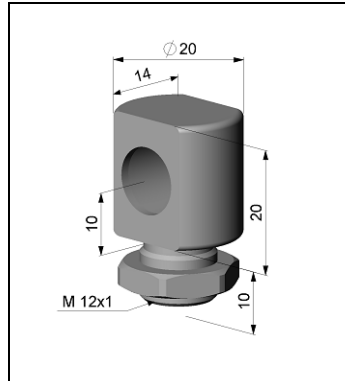

Mounting bolt with M12x1 thread, adjustable in one axis [ACCTMB]

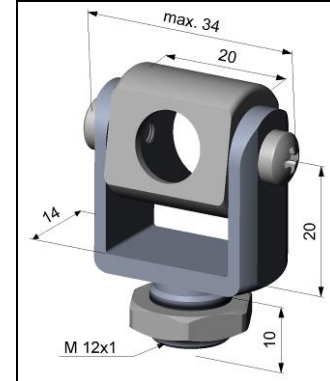

Mounting fork with M12x1 thread, adjustable in 2 axes [ACCTMG]



**Mounting bracket, adjustable in two axes [ACCTAB]
consisting of: ACCTFB and ACCTMB**

The Mounting fork can be combined with the Mounting bracket [ACCTFB] using the M12x1 thread.

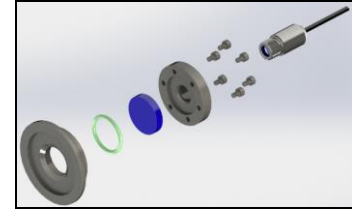
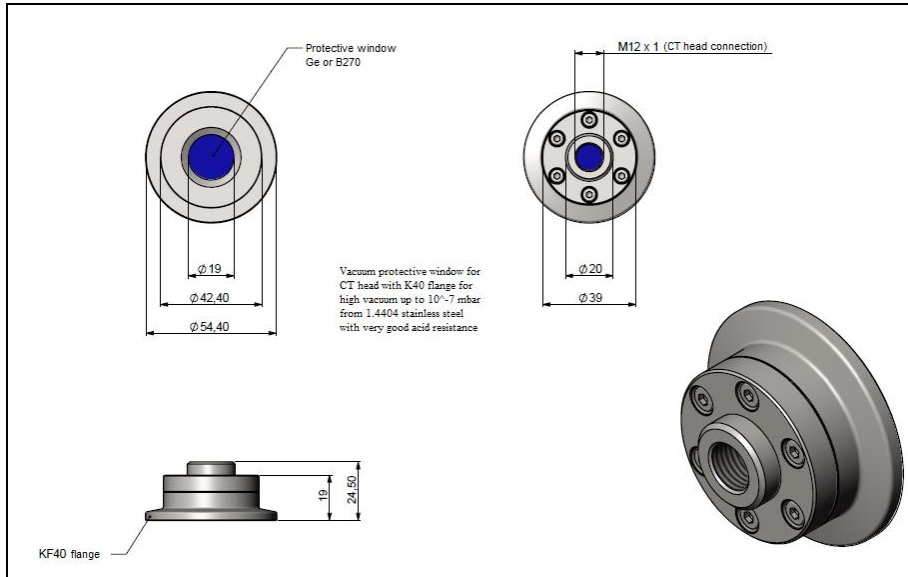

K40 flange [ACCTKF40GE] for CTLT with Ge window or [ACCTKF40B270] for CT1M, 2M, 3M with B270 window



When changing the windows, the screws must be tightened with a tightening torque of 1 Nm.

3.2 Air Purge Collars

The lens must be kept clean at all times from dust, smoke, fumes and other contaminants in order to avoid reading errors. These effects can be reduced by using an air purge collar. Make sure to use oil-free, technically clean air, only.

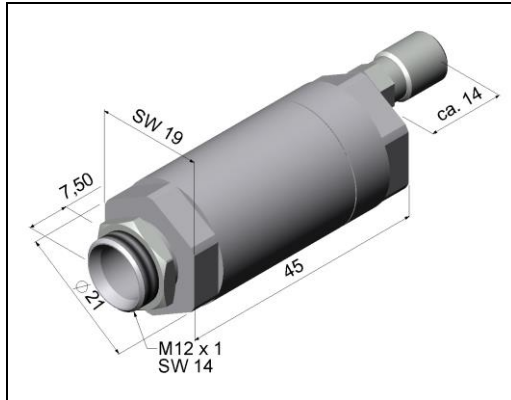

Standard air purge collar [ACCTAP] for optics with a D:S \geq 10:1 (not for sensing heads with 32 mm length), fits to the mounting bracket
Hose connection: 3x5 mm
Thread (fitting): M5

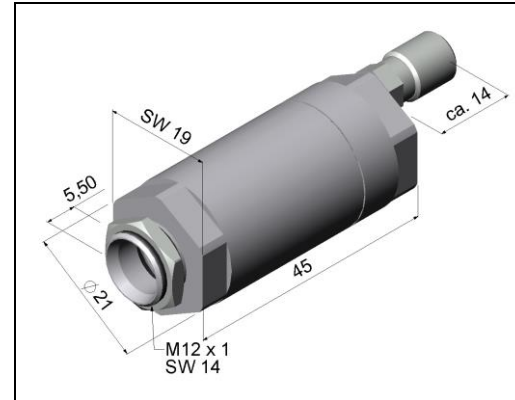

Standard air purge collar [ACCTAP2] for optics with a D:S \leq 2:1 (not for sensing heads with 32 mm length), fits to the mounting bracket
Hose connection: 3x5 mm
Thread (fitting): M5

The needed amount of air (approx. 2...10 l/ min.) depends on the application and the installation conditions on-site.

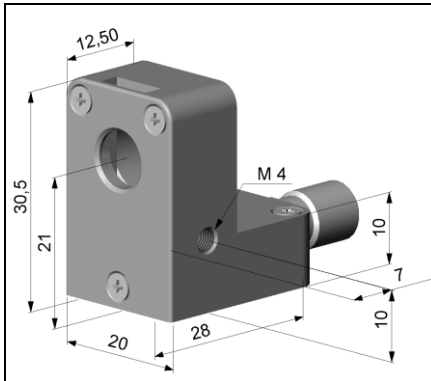

Laminar air purge collar [ACCTAPL]
The sideward air outlet prevents a cooling down of the object in short distances.
Hose connection: 3x5 mm
Thread (fitting): M5



Laminar air purge collar with mounting fork [ACCTAPLMF],
adjustable in 2 axes

The needed amount of air (approx. 2...10 l/ min.) depends on the application and the installation conditions on-site.

3.3 Further Accessories

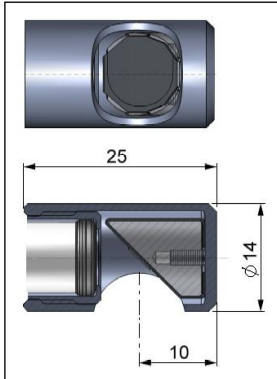

Right Angle Mirror [ACCTRAM]

for optics with a D:S \geq 10:1;

enables measurements with 90° angle to sensor axis.

The mirror has a reflexion of 96% in combination with a LT22 and LT15 head and 88% with a LT15F head.

If the mirror is used this value has to be multiplied by the emissivity value of the measurement object.

Example: LT22 and object with emissivity = 0,85

$0,85 \times 0,96 = 0,816$

Thus the emissivity in the CT has to be set to the resulting value of 0,816.



Laser-Sighting tool [D08ACCTLST]

battery powered (2x Alcaline AA), for alignment of CT sensing heads. The laser head has the same mechanical dimensions as the CT sensing head.

WARNING: Do not point the laser directly at the eyes of persons or animals! Do not stare into the laser beam. Avoid indirect exposure via reflective surfaces!



OEM-Laser-Sightingtool

The OEM-Laser-Sighting tool is available with 3,5 m [ACCTOEMLST] and 8 m connection cable [ACCTOEMLSTCB8]. The laser can be connected to the pins **3V SW** and **GND** [► 4 Electrical Installation] and switched on and off via the programming keys or via the software.

The special double-hole mounting bracket [ACCTFB2] allows a simultaneous mounting of the CT sensing head and the laser head.

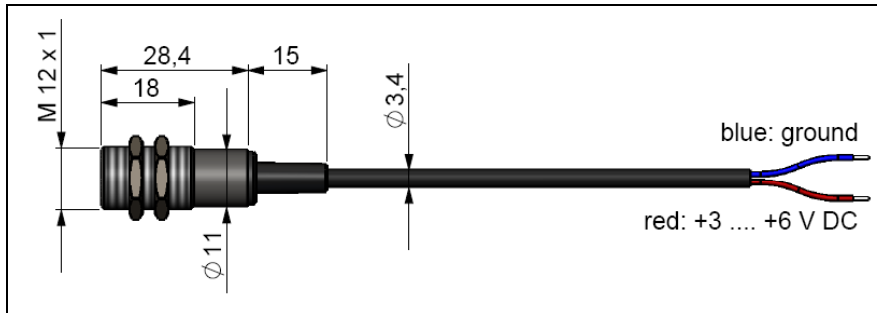

OEM-Laser-Sighting tool [ACCTOEMLST or ACCTOEMLSTCB8]

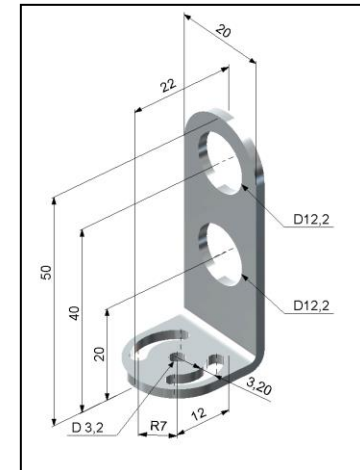

Mounting bracket [ACCTFB2]

Massive Housing

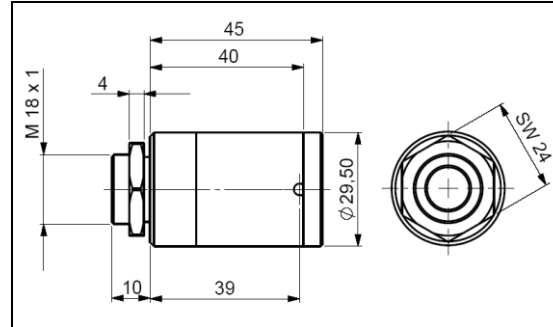

Massive housing, stainless steel [D06ACCTMHS] – also available in aluminum (anodized) or brass

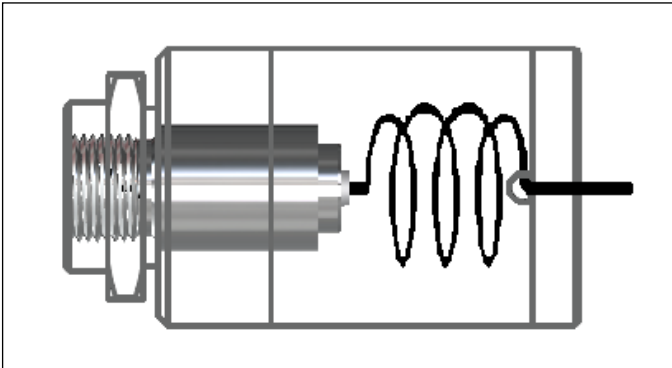

The Massive housing allows reproducible and stable measurements on applications with significant and short-term variation in ambient temperatures. It can be combined with the CF lens [ACCTCFE] or with the protective window [ACCTPWE].

► 2.8 CF Lens and Protective Window

IMPORTANT: For an optimum function of the massive housing 10 cm of the head cable must be installed in loops inside the housing.

Accessories for Massive Housing

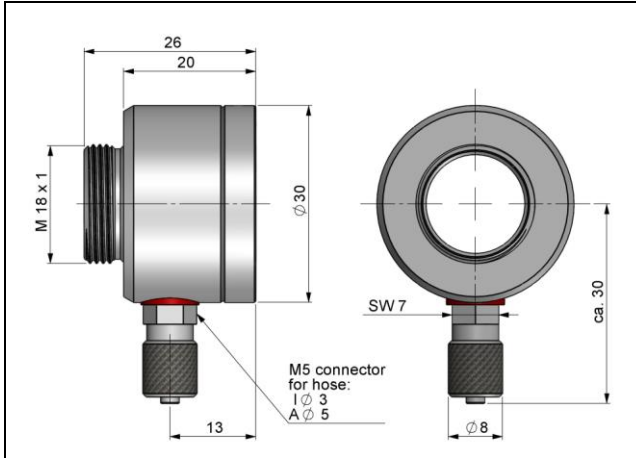

**Air purge collar for massive housing (thread M18x1)
[ACCTAPMH]**

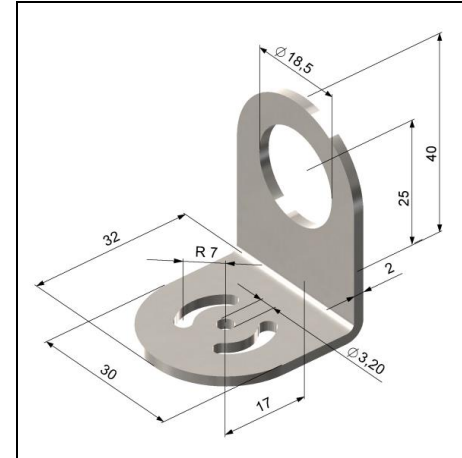

**Mounting bracket for massive housing,
adjustable in one axis [ACCTFBMH]**

The needed amount of air (approx. 2...10 l/ min.) depends on the application and the installation conditions on-site.

Pipe Adapter and Sighting Tubes

The pipe adapter [ACCTPA] allows an assembling of sighting tubes directly on the CT head. The sighting tubes are available in 3 different lengths:

ACCTST20	20 mm
ACCTST40	40 mm
ACCTST88	88 mm

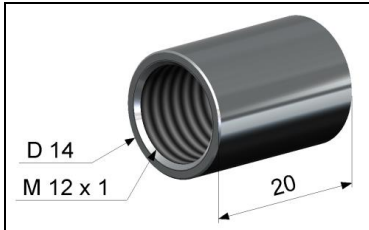

Pipe adapter [ACCTPA]

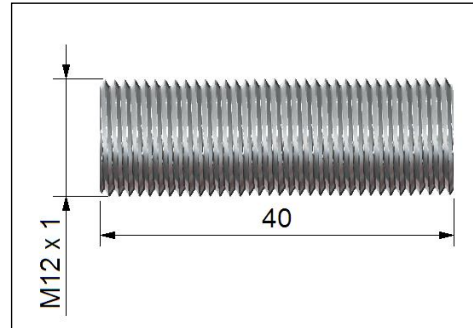

Sighting tube [ACCTST40]

The sighting tubes can only be used for sensing heads with a distance-to-spot ratio (D:S) of $\geq 15:1$.

Rail Mount Adapter for Electronic box

With the rail mount adapter the CT electronics can be mounted easily on a DIN rail (TS35) according EN50022.

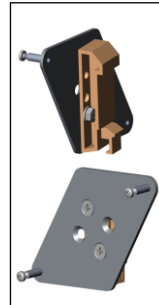
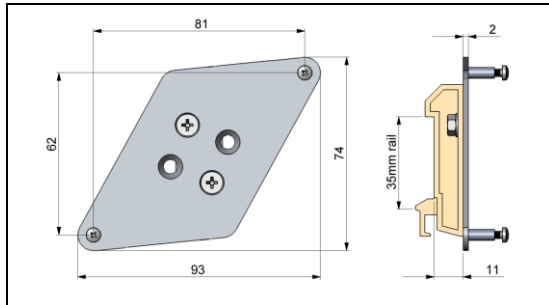

Rail Mount Adapter [ACCTRAIL]

Tilt Assembly for CT heads

With this mounting accessory a fine adjustment of the CT head with an off-axis angle $\pm 6,5^\circ$ is possible.

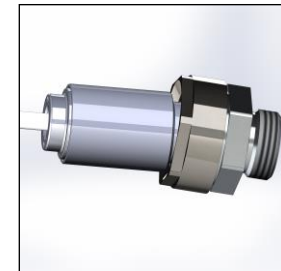
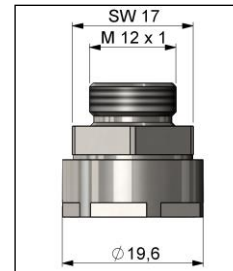

Tilt assembly [ACCTTAS]

Accessories for IRmobile app

The IR App Connector is used to connect the sensor to a smartphone or tablet (► **7 IRmobile app**). The connector cable can be also used for the connection to your PC in combination with the software CompactConnect which can be downloaded for free under <https://www.optris.global/downloads-software>.

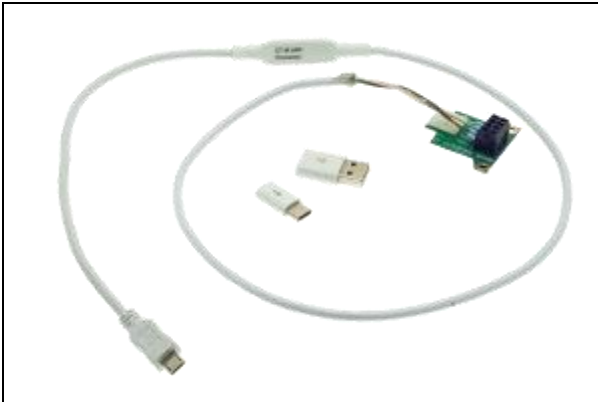

IR app Connector: USB programming adaptor [ACCTIAC]

4 Electrical Installation

4.1 Cable Connections

For the electrical installation of the CT please open at first the cover of the electronic box (4 screws). Below the display are the screw terminals for the cable connection.

Designation [models LT/ G5/ P3/ P7]

+8...36 VDC	Power supply
GND	Ground (0 V) of power supply
GND	Ground (0 V) of internal in- and outputs
OUT-AMB	Analog output head temperature (mV)
OUT-TC	Analog output thermocouple (J or K)
OUT-mV/mA	Analog output object temperature (mV or mA)
F1-F3	Functional inputs
AL2	Alarm 2 (Open collector output)
3V SW	3 VDC, switchable, for laser-sightingtool
GND	Ground (0 V) for laser-sightingtool
BROWN	Temperature probe head
WHITE	Temperature probe head
GREEN	Detector signal (-)
YELLOW	Detector signal (+)



Opened LT/ G5/ P3/ P7 electronic box
with terminal connections

Designation [models 1M/ 2M/ 3M]

+8...36 VDC	Power supply
GND	Ground (0 V) of power supply
GND	Ground (0 V) of internal in- and outputs
AL2	Alarm 2 (Open collector output)
OUT-TC	Analog output thermocouple (J or K)
OUT-mV/mA	Analog output object temperature (mV or mA)
F1-F3	Functional inputs
GND	Ground (0 V)
3V SW	3 VDC, switchable, for laser-sightingtool
GND	Ground (0 V) for laser-sightingtool
BROWN	Temperature probe head (NTC)
WHITE	Head ground
GREEN	Head power
YELLOW	Detector signal

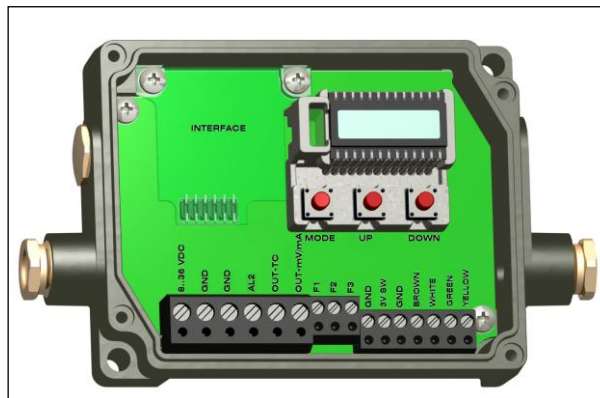

Opened 1M/ 2M/ 3M electronic box
with terminal connections

Power supply

Please use a stabilized power supply unit with an output voltage in the range of **8–36 VDC** which can supply **100 mA**. The ripple should be max. **200 mV**.



Please do never connect a supply voltage to the analog outputs as this will destroy the output!

The CT is not a 2-wire sensor!

Cable Assembling

The cable gland M12x1,5 allows the use of cables with a diameter of 3 to 5 mm.

Remove the isolation from the cable (40 mm power supply, 50 mm signal outputs, 60 mm functional inputs).

Cut the shield down to approximately 5 mm and spread the strands out. Extract about 4 mm of the wire isolation and tin the wire ends.

Place the pressing screw, the rubber washer and the metal washers of the cable gland one after the other onto the prepared cable end. Spread the strands and fix the shield between two of the metal washers. Insert the cable into the cable gland until the limit stop. Screw the cap tight.

Every single wire may be connected to the according screw clamps according to their colors.

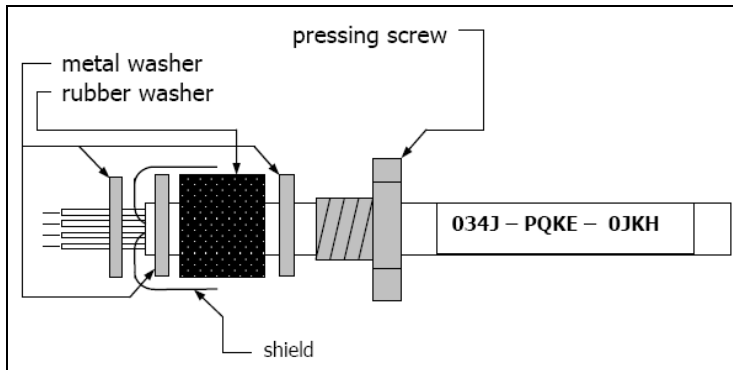

Use shielded cables only. The sensor shield has to be grounded.

4.2 Ground Connection

4.2.1 1M, 2M, 3M models

At the bottom side of the mainboard PCB you will find a connector (jumper) which has been placed from factory side as shown in the picture [**bottom** and **middle** pin connected]. In this position the ground connections (GND power supply/ outputs) are connected with the ground of the electronics housing.

To avoid ground loops and related signal interferences in industrial environments it might be necessary to interrupt this connection. To do this put the jumper in the opposite position [**middle** and **top** pin connected].

If the thermocouple output is used the connection GND – housing should be interrupted generally.

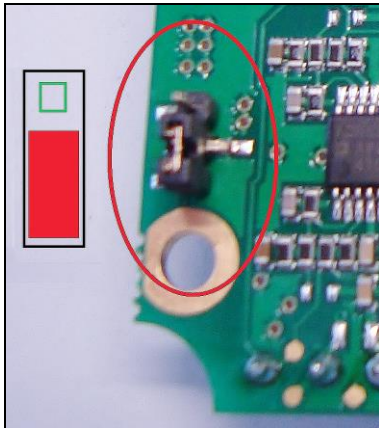

4.2.2 LT, LTF, LTH, G5, P3, P7 models

At the bottom side of the mainboard PCB you will find a connector (jumper) which has been placed from factory side as shown in the picture [**left** and **middle** pin connected]. In this position the ground connections (GND power supply/ outputs) are connected with the ground of the electronics housing.

To avoid ground loops and related signal interferences in industrial environments it might be necessary to interrupt this connection. To do this please put the jumper in the other position [**middle** and **right** pin connected].

If the thermocouple output is used the connection GND – housing should be interrupted generally.

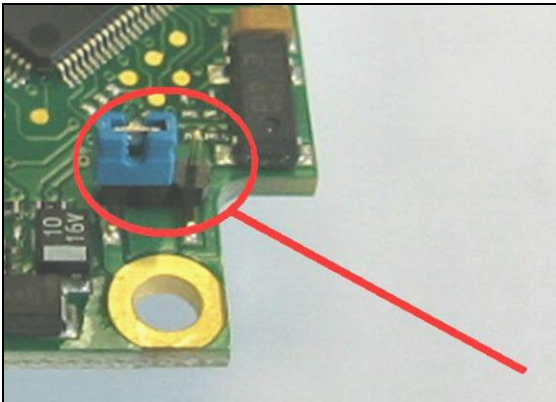

4.3 Exchange of the Sensing Head

From factory side the sensing head has already been connected to the electronics and the calibration code has been entered. Inside a certain model group any exchange of sensing heads and electronics is possible. The sensing heads and electronics of the **CTfast** models **LT15F** and **LT25F** cannot be exchanged.

After exchanging a head the calibration code of the new head must be entered into the electronics.

Entering of the Calibration Code

Every head has a specific calibration code, which is printed on the head cable. For a correct temperature measurement and functionality of the sensor this calibration code must be stored into the electronic box. The calibration code consists of **3 blocks** (1M, 2M, 3M = 5 blocks) with **4 characters** each.

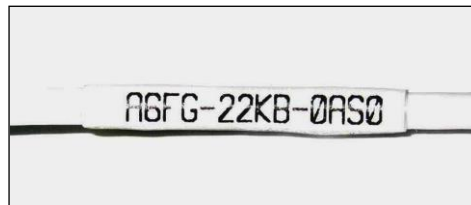

Example: **A6FG – 22KB – 0AS0**
 block1 block2 block3

For entering the code please press the **Up** and **Down** key (keep pressed) and **then** the **Mode** key. The display shows **HCODE** and then the 4 signs of the first block. With **Up** and **Down** each sign can be changed; **Mode** switches to the next sign or next block. The entering of a new calibration code can also be made via the CompactConnect software (optional).



You will find the calibration code on a label fixed on the head cable (near the electronics). Please do not remove this label or make sure the code is noted anywhere. The code is needed if the electronics has to be exchanged or in case of a necessary recalibration of the sensor.



After you have modified the head code a reset is necessary to activate the change.
[▶ 6 Operating]

Sensing Head Cable

On all CT models (**exception 3M, P3, P7**) the sensing head cable can be shortened if necessary.

On the models **1M, 2M** and **CTfast** the sensing head cable can be shortened by max. **3 m**.

A shortening of the cable will cause an additional measuring error of about **0,1 K/ m**.

The **3M** models are only available with **3 m** cable.



On the CT models LT02, LT02H and LT10H the head cable must not be moved during the measurement.

5 Outputs and Inputs

5.1 Analog Outputs

The CT has two analog output channels.

CAUTION: Please do never connect a supply voltage to the analog outputs as this will destroy the output. The CT is not a 2-wire sensor!

Output channel 1

This output is used for the object temperature. The selection of the output signal can be done via the programming keys [**► 6 Operating**]

]. The software allows the programming of output channel 1 as an alarm output.

Output signal	Range	Connection pin on CT board
Voltage	0 ... 5 V	OUT-mV/mA
Voltage	0 ... 10 V	OUT-mV/mA
Current	0 ... 20 mA	OUT-mV/mA
Current	4 ... 20 mA	OUT-mV/mA
Thermocouple	TC J	OUT-TC
Thermocouple	TC K	OUT-TC

According to the chosen output signal different connection pins on the mainboard are used (**OUT-mV/mA** or **OUT-TC**).

Output channel 2 [LT/ G5/ P3/ P7 only]

The connection pin OUT-AMB is used for output of the head temperature **[-20-180 °C or -20-250 °C (on LT02H and LT10H) as 0–5 V or 0–10 V signal]**. The software allows the programming of output channel 2 as an alarm output.

Instead of the head temperature T_{Head} also the object temperature T_{Obj} or electronic box temperature T_{Box} can be selected as alarm source.

5.2 Digital Interfaces

CT sensors can be optionally equipped with an USB-, RS232-, RS485-, CAN Bus-, Profibus DP- or Ethernet-interface.

If you want to install an interface, plug the interface board into the place provided, which is located beside the display. In the correct position the holes of the interface match with the thread holes of the electronic box. Now press the board down to connect it and use both M3x5 screws for fixing it. Plug the preassembled interface cable with the terminal block into the male connector of the interface board.

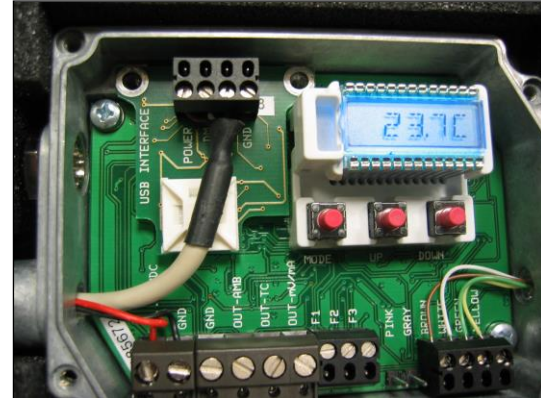

**The Ethernet interface requires at minimum 12 V supply voltage.
Please pay attention to the notes on the according interface manuals.**

5.3 Relay Outputs

The CT can be optionally equipped with a relay output. The relay board will be installed the same way as the digital interfaces. **A simultaneous installation of a digital interface and the relay outputs is not possible.** The relay board provides two fully isolated switches, which have the capability to switch max. 60 VDC/ 42 VAC_{RMS}, 0,4 A DC/AC. A red LED shows the closed switch.



The switching thresholds are in accordance with the values for alarm 1 and 2 [► 5.5 Alarms].
The alarm values are set according to the ► 1.6 Factory Default Settings.
To make advanced settings (change of low- and high alarm) a digital interface (USB, RS232) and the software is needed.

5.4 Functional Inputs

The three functional inputs F1 – F3 can be programmed with the software only.

- F1 (digital):** trigger (a 0 V level on F1 resets the hold functions)
F2 (analog): external emissivity adjustment [0–10 V: 0 V ► $\epsilon = 0,1$; 9 V ► $\epsilon = 1$; 10 V ► $\epsilon = 1,1$]
F3 (analog): external compensation of ambient temperature/ the range is scalable via software
[0–10 V ► -40–900 °C / preset range: -20–200 °C]
F1-F3 (digital): emissivity (digital choice via table)

A non connected input represents:

F1 = High | F2, F3 = Low.

[High level: $\geq +3$ V...+36 V | Low level: $\leq +0,4$ V...-36 V]

5.5 Alarms

The CT has the following Alarm features:

All alarms (alarm 1, alarm 2, output channel 1 and 2 if used as alarm output) have a fixed **hysteresis of 2 K (CThot: 1 K)**.

Output channel 1 and 2 [channel 2 on LT/ G5/ P3/ P7 only]

To activate the according output channel has to be switched into digital mode. For this purpose the software CompactConnect is required.

Visual Alarms

These alarms will cause a change of the color of the LCD display and will also change the status of the optional relays interface. In addition the Alarm 2 can be used as open collector output at pin **AL2** on the mainboard [**24 V/ 50 mA**].

From factory side the alarms are defined as follows:

Alarm 1	Norm. closed/ Low-Alarm
Alarm 2	Norm. open/ High-Alarm

Both of these alarms will have effect on the LCD color:

BLUE: alarm 1 active
RED: alarm 2 active
GREEN: no alarm active

For extended setup like definition as low or high alarm [**via change of normally open/ closed**], selection of the signal source [**T_{Obj}, T_{Head}, T_{Box}**] a digital interface (e.g. USB, RS232) including the software CompactConnect is needed.

Open collector output / AL2:

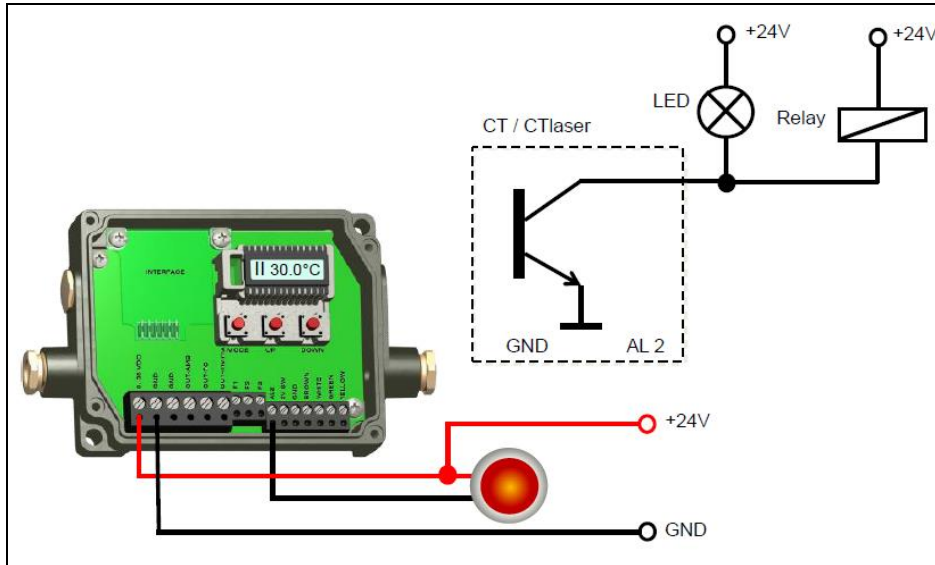

- The transistor acts as a switch. In case of alarm, the contact is closed.
- A load/consumer (Relay, LED or a resistor) must always be connected.
- The alarm voltage (here 24V) must not be connected directly to the alarm output (short circuit).

6 Operating

After power up the unit the sensor starts an initializing routine for some seconds. During this time the display will show **INIT**. After this procedure the object temperature is shown in the display. The display backlight color changes according to the alarm settings [► **5.5 Alarms**].

6.1 Sensor Setup

The programming keys **Mode**, **Up** and **Down** enable the user to set the sensor on-site. The current measuring value or the chosen feature is displayed. With **Mode** the operator obtains the chosen feature, with **Up** and **Down** the functional parameters can be selected – **a change of parameters will have immediate effect**. If no key is pressed for more than 10 seconds the display automatically shows the calculated object temperature (according to the signal processing).

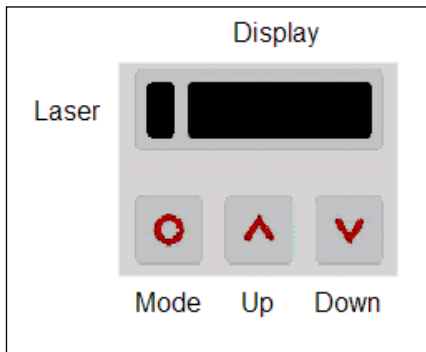

Pressing the Mode button again recalls the last called function on the display. The signal processing features **Peak hold** and **Valley hold** cannot be selected simultaneously.

Factory Default Setting

To set the CT back to the factory default settings, please press at first the **Down**-key and then the **Mode**-key and keep both pressed for approx. 3 seconds.

The display will show **RESET** for confirmation.

Display	Mode [Sample]	Adjustment Range
142.3C	Object temperature (after signal processing) [142,3 °C]	fixed
127CH	Head temperature [127 °C]	fixed
25CB	Box temperature [25 °C]	fixed
142CA	Current object temperature [142 °C]	fixed
δ MV5	Signal output channel 1 [0-5 V]	δ 0-20 = 0–20 mA/ δ 4-20 = 4–20 mA/ δ MV5 = 0–5 V/ δ MV10 = 0-10 V/ δ TCJ = thermocouple type J/ δ TCK = thermocouple type K
E0.970	Emissivity [0,970]	0,100 ... 1,100
T1.000	Transmissivity [1,000]	0,100 ... 1,100
A 0.2	Signal output Average [0,2 s]	A---- = inactive/ 0,1 ... 999,9 s
P----	Signal output Peak hold [inactive]	P---- = inactive/ 0,1 ... 999,9 s / P oo oo oo oo = infinite
V----	Signal output Valley hold [inactive]	V---- = inactive/ 0,1 ... 999,9 s / V oo oo oo oo = infinite
u 0.0	Lower limit temperature range [0 °C]	depending on model / inactive at TCJ- and TCK-output
n 500.0	Upper limit temperature range [500 °C]	depending on model / inactive at TCJ- and TCK-output
[0.00	Lower limit signal output [0 V]	according to the range of the selected output signal
] 5.00	Upper limit signal output [5 V]	according to the range of the selected output signal
U °C	Temperature unit [°C]	°C/ °F
 30.0	Lower alarm limit [30 °C]	depending on model
 100.0	Upper alarm limit [100 °C] AL2	depending on model
XHEAD	Ambient temperature compensation [head temperature]	XHEAD = head temperature/ -40,0 ... 900,0 °C (for LT) as fixed value for compensation/ returning to XHEAD (head temperature) by pressing Up and Down together
M 01	Multidrop adress [1] (only with RS485 interface) RS422 mode	01 ... 32 RS422 (Press Down button on M01)
B 9.6	Baud rate in kBaud [9,6]	9,6/ 19,2/ 38,4/ 57,6/ 115,2 kBaud
S ON	Laser Sighting (3 VDC switch to connection pin 3V SW)	ON/ OFF This menu item appears on first position on 1M/ 2M/ 3M models.

- ð MV5** Selection of the **Output signal**. By pressing **Up** or **Down** the different output signals can be selected (see table).
- E0.970** Setup of **Emissivity**. Pressing **Up** increases the value, **Down** decreases the value (also valid for all further functions). The emissivity is a material constant factor to describe the ability of the body to emit infrared energy [**► 10 Emissivity**].
- T1.000** Setup of **Transmissivity**. This function is used if an optical component (protective window, additional optics e.g.) is mounted between sensor and object. The standard setting is 1.000 = 100 % (if no protective window etc. is used).
- A 0.2** Setup of **Average time**. In this mode an arithmetic algorithm will be performed to smoothen the signal. The set time is the time constant. This function can be combined with all other post processing functions. On 1M/ 2M/ 3M models the shortest value is 0,001 s (other models: 0,1 s) and can be increased/ decreased only by values of the power series of 2 (0,002, 0,004, 0,008, 0,016, 0,032, ...).
If the value is set to **0.0** the display will show --- (function deactivated).
- P----** Setup of **Peak hold**. In this mode the sensor is waiting for descending signals. If the signal descends the algorithm maintains the previous signal peak for the specified time. After the hold time the signal will drop down to the second highest value or will descend by 1/8 of the difference between the previous peak and the minimum value during the hold time. This value will be held again for the specified time. After this the signal will drop down with slow time constant and will follow the current object temperature.
If the value is set to **0.0** the display will show --- (function deactivated).
- V----** Setup of **Valley hold**. In this mode the sensor waits for ascending signals. The definition of the algorithm is according to the peak hold algorithm (inverted).
If the value is set to **0.0** the display will show --- (function deactivated).

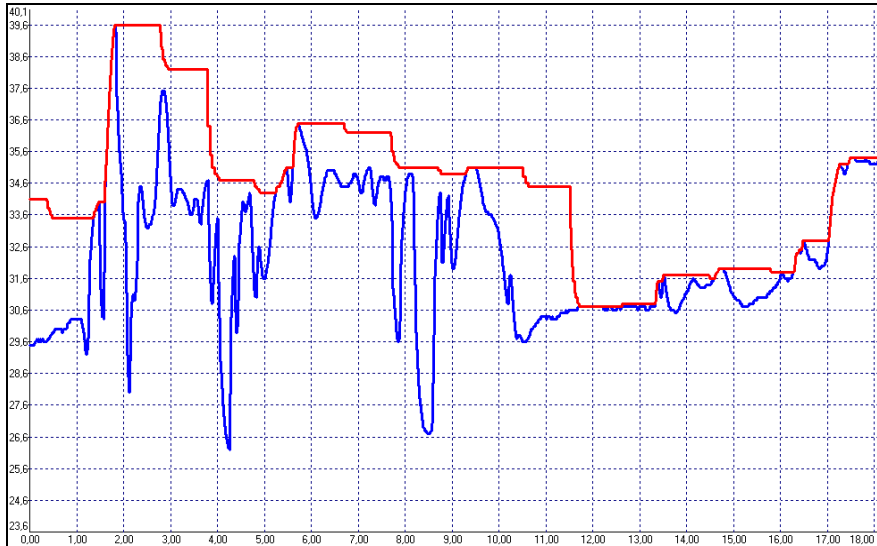
Signal graph with **P----**

— TProcess with Peak Hold (Hold time = 1s)

— Actual without post processing

- u 0.0** Setup of the **Lower limit of temperature range**. The minimum difference between lower and upper limit is **20 K**. If you set the lower limit to a value \geq upper limit the upper limit will be adjusted to **[lower limit + 20 K]** automatically.
- n 500.0** Setup of the **Upper limit of the temperature range**. The minimum difference between upper and lower limit is **20 K**. The upper limit can only be set to a value = lower limit + 20 K.
- [0.00** Setup of the **Lower limit of the signal output**. This setting allows an assignment of a certain signal output level to the lower limit of the temperature range. The adjustment range corresponds to the selected output mode (e.g. 0-5 V).
-] 5.00** Setup of the **Upper limit of the signal output**. This setting allows an assignment of a certain signal output level to the upper limit of the temperature range. The adjustment range corresponds to the selected output mode (e.g. 0-5 V).
- U °C** Setup of the **Temperature unit** [°C or °F].
- | 30.0** Setup of the **Lower alarm limit**. This value corresponds to Alarm 1 **[► 5.5 Alarms]** and is also used as threshold value for relay 1 (if the optional relay board is used).
- || 100.0** Setup of the **Upper alarm limit**. This value corresponds to Alarm 2 **[► 5.5 Alarms]** and is also used as threshold value for relay 2 (if the optional relay board is used).
- XHEAD** Setup of the **Ambient temperature compensation**. In dependence on the emissivity value of the object a certain amount of ambient radiation will be reflected from the object surface. To compensate this impact, this function allows the setup of a fixed value which represents the ambient radiation.



Especially if there is a big difference between the ambient temperature at the object and the head temperature the use of **Ambient temperature compensation** is recommended.

- M 01** Setup of the **Multidrop address**. In a **RS485** network each sensor will need a specific address. This menu item will only be shown if a RS485 interface board is plugged in. For using the **RS422** mode, press once the down button on M01.
- B 9.6** Setup of the **Baud rate** for digital data transfer.
- S ON** Activating (**ON**) and Deactivating (**OFF**) of an optional **Sighting Laser** [**► 3.3 Further Accessories**]. By pressing **Up** or **Down** a voltage of 3 VDC will be switched to the **3V SW** connection pin on the mainboard.

6.2 Error messages

The display of the sensor can show the following error messages:

LT/ G5/ P3/ P7 models:

OVER	Object temperature too high
UNDER	Object temperature too low
^^CH	Head temperature too high
vvCH	Head temperature too low

1M/ 2M/ 3M models:

1. Digit:

0x	No error
1x	Head temperature probe short circuit to GND
2x	Box temperature too low
4x	Box temperature too high
6x	Box temperature probe disconnected
8x	Box temperature probe short circuit to GND

2. Digit:

x0	No error
x2	Object temperature too high
x4	Head temperature too low
x8	Head temperature too high
xC	Head temperature probe disconnected

7 IRmobile app

The CT sensor has a direct connection to an Android smartphone or tablet. All you have to do is download the IRmobile app for free in the Google Play Store. This can also be done via the QR code. An IR app connector is required for connection to the device (**Part-No.: ACCTIAC**).

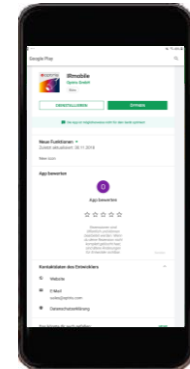

With IRmobile you are able to monitor and analyse your infrared temperature measurement on a connected smartphone or tablet. This app works on most Android devices running 4.4 or higher with a micro USB port supporting USB-OTG (On The Go). It is easy to operate: after you plug your CT device to the micro USB port of your phone or tablet, the app will start automatically. The device is powered by your phone. Different digital temperature values can be displayed in the temperature time diagram. You can easily zoom-in the diagram to see more details and small signal changes.

IRmobile app features:

- Temperature time diagram with zoom function
- Digital temperature values
- Setup of emissivity, transmissivity and other parameters
- Scaling of 4-20 mA/ 0-10 V output and setup of alarm output
- Change of temperature unit: Celsius or Fahrenheit
- Saving/loading of configurations and T/t diagrams
- Restore factory default sensor settings
- Integrated simulator

Supported for:

- CT/CTlaser sensor
- CSmicro IR thermometers (v3 models only)
- For android devices running 4.4+ with a micro USB port supporting USB-OTG (On The Go)

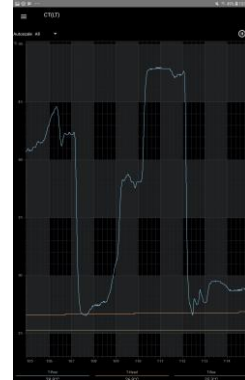

8 Software CompactConnect

8.1 Installation

Insert the installation CD into the according drive on your computer. If the autorun option is activated the installation wizard will start automatically.

Otherwise please start **CDsetup.exe** from the CD-ROM. Follow the instructions of the wizard until the installation is finished.

The installation wizard will place a launch icon on the desktop and in the start menu:

[Start]ProgramsCompactConnect.

If you want to uninstall the software from your system please use the **uninstall icon** in the start menu.

Minimum system requirements:

- Windows 7, 8, 10
- USB interface
- Hard disc with at least 30 MByte free space
- At least 128 MByte RAM
- CD-ROM drive



A detailed description is provided in the software manual on the software CD.

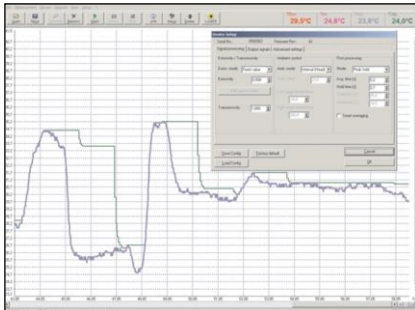

Main Features:

- Graphic display for temperature trends and automatic data logging for analysis and documentation
- Complete sensor setup and remote controlling
- Adjustment of signal processing functions
- Programming of outputs and functional inputs

8.2 Communication Settings

Serial Interface

Baud rate: 9,6...115,2 kBaud (adjustable on the unit or via software)
Data bits: 8
Parity: none
Stop bits: 1
Flow control: off

Protocol

All sensors of the CT series are using a binary protocol. Alternatively they can be switched to an ASCII protocol. To get a fast communication the protocol has no additional overhead with CR, LR or ACK bytes.

Saving of parameter settings

After power on of the CT sensor the flash mode is active. It means, changed parameter settings will be saved in the CT-internal Flash-EEPROM and will be kept also after the sensor is switched off.

In case settings should be changed quite often or continuously the flash mode can be switched off by using the following command:

Decimal: **112**
HEX: **0x70**
Data, Answer: **byte 1**
Result: **0 – Data will be written into the flash memory**
 1 – Data will not be written into the flash memory

If the flash mode is deactivated, all settings will only be kept as long as the unit is powered. If the unit is switched off and powered on again all previous settings are lost.

The command 0x71 will poll the current status.

You will find a detailed protocol and command description on the software CD CompactConnect in the directory: **\Commands**.

9 Basics of Infrared Thermometry

Depending on the temperature each object emits a certain amount of infrared radiation. A change in the temperature of the object is accompanied by a change in the intensity of the radiation. For the measurement of “thermal radiation” infrared thermometry uses a wave-length ranging between 1 μm and 20 μm .

The intensity of the emitted radiation depends on the material. This material contingent constant is described with the help of the emissivity which is a known value for most materials (► **10 Emissivity**).

Infrared thermometers are optoelectronic sensors. They calculate the surface temperature on the basis of the emitted infrared radiation from an object. The most important feature of infrared thermometers is that they enable the user to measure objects contactless. Consequently, these products help to measure the temperature of inaccessible or moving objects without difficulties. Infrared thermometers basically consist of the following components:

- lens
- spectral filter
- detector
- electronics (amplifier/ linearization/ signal processing)

The specifications of the lens decisively determine the optical path of the infrared thermometer, which is characterized by the ratio Distance to Spot size.

The spectral filter selects the wavelength range, which is relevant for the temperature measurement. The detector in cooperation with the processing electronics transforms the emitted infrared radiation into electrical signals.

10 Emissivity

10.1 Definition

The intensity of infrared radiation, which is emitted by each body, depends on the temperature as well as on the radiation features of the surface material of the measuring object. The emissivity (ϵ – Epsilon) is used as a material constant factor to describe the ability of the body to emit infrared energy. It can range between 0 and 100 %. A “blackbody” is the ideal radiation source with an emissivity of 1,0 whereas a mirror shows an emissivity of 0,1.

If the emissivity chosen is too high, the infrared thermometer may display a temperature value which is much lower than the real temperature – assuming the measuring object is warmer than its surroundings. A low emissivity (reflective surfaces) carries the risk of inaccurate measuring results by interfering infrared radiation emitted by background objects (flames, heating systems, chamottes). To minimize measuring errors in such cases, the handling should be performed very carefully and the unit should be protected against reflecting radiation sources.

10.2 Determination of unknown Emissivity

- ▶ First, determine the actual temperature of the measuring object with a thermocouple or contact sensor. Second, measure the temperature with the infrared thermometer and modify the emissivity until the displayed result corresponds to the actual temperature.
- ▶ If you monitor temperatures of up to 380 °C you may place a special plastic sticker (emissivity dots – part number: ACLSED) onto the measuring object, which covers it completely. Now set the emissivity to 0,95 and take the temperature of the sticker. Afterwards, determine the temperature of the adjacent area on the measuring object and adjust the emissivity according to the value of the temperature of the sticker.

- ▶ Cover a part of the surface of the measuring object with a black, flat paint with an emissivity of 0,98. Adjust the emissivity of your infrared thermometer to 0,98 and take the temperature of the colored surface. Afterwards, determine the temperature of a directly adjacent area and modify the emissivity until the measured value corresponds to the temperature of the colored surface.

CAUTION: On all three methods the object temperature must be different from ambient temperature.

10.3 Characteristic Emissivity

In case none of the methods mentioned above help to determine the emissivity you may use the emissivity tables ▶ **Appendix A – Table of Emissivity for metals** and **Appendix B – Table of Emissivity for non-metals**. These are average values, only. The actual emissivity of a material depends on the following factors:

- temperature
- measuring angle
- geometry of the surface
- thickness of the material
- constitution of the surface (polished, oxidized, rough, sandblast)
- spectral range of the measurement
- transmissivity (e.g. with thin films)

Appendix A – Table of Emissivity for metals

Material		typical Emissivity			
Spectral response		1,0 μm	1,6 μm	5,1 μm	8-14 μm
Aluminium	non oxidized	0,1-0,2	0,02-0,2	0,02-0,2	0,02-0,1
	polished	0,1-0,2	0,02-0,1	0,02-0,1	0,02-0,1
	roughened	0,2-0,8	0,2-0,6	0,1-0,4	0,1-0,3
	oxidized	0,4	0,4	0,2-0,4	0,2-0,4
Brass	polished	0,35	0,01-0,05	0,01-0,05	0,01-0,05
	roughened	0,65	0,4	0,3	0,3
	oxidized	0,6	0,6	0,5	0,5
Copper	polished	0,05	0,03	0,03	0,03
	roughened	0,05-0,2	0,05-0,2	0,05-0,15	0,05-0,1
	oxidized	0,2-0,8	0,2-0,9	0,5-0,8	0,4-0,8
Chrome		0,4	0,4	0,03-0,3	0,02-0,2
Gold		0,3	0,01-0,1	0,01-0,1	0,01-0,1
Haynes	alloy	0,5-0,9	0,6-0,9	0,3-0,8	0,3-0,8
Inconel	electro polished	0,2-0,5	0,25	0,15	0,15
	sandblast	0,3-0,4	0,3-0,6	0,3-0,6	0,3-0,6
	oxidized	0,4-0,9	0,6-0,9	0,6-0,9	0,7-0,95
Iron	non oxidized	0,35	0,1-0,3	0,05-0,25	0,05-0,2
	rusted		0,6-0,9	0,5-0,8	0,5-0,7
	oxidized	0,7-0,9	0,5-0,9	0,6-0,9	0,5-0,9
	forged, blunt	0,9	0,9	0,9	0,9
	molten	0,35	0,4-0,6		
Iron, casted	non oxidized	0,35	0,3	0,25	0,2
	oxidized	0,9	0,7-0,9	0,65-0,95	0,6-0,95

Material		typical Emissivity			
		1,0 μm	1,6 μm	5,1 μm	8-14 μm
Lead	polished	0,35	0,05-0,2	0,05-0,2	0,05-0,1
	roughened	0,65	0,6	0,4	0,4
	oxidized		0,3-0,7	0,2-0,7	0,2-0,6
Magnesium		0,3-0,8	0,05-0,3	0,03-0,15	0,02-0,1
Mercury			0,05-0,15	0,05-0,15	0,05-0,15
Molybdenum	non oxidized	0,25-0,35	0,1-0,3	0,1-0,15	0,1
	oxidized	0,5-0,9	0,4-0,9	0,3-0,7	0,2-0,6
Monel (Ni-Cu)		0,3	0,2-0,6	0,1-0,5	0,1-0,14
Nickel	electrolytic	0,2-0,4	0,1-0,3	0,1-0,15	0,05-0,15
	oxidized	0,8-0,9	0,4-0,7	0,3-0,6	0,2-0,5
Platinum	black		0,95	0,9	0,9
Silver		0,04	0,02	0,02	0,02
Steel	polished plate	0,35	0,25	0,1	0,1
	rustless	0,35	0,2-0,9	0,15-0,8	0,1-0,8
	heavy plate			0,5-0,7	0,4-0,6
	cold-rolled	0,8-0,9	0,8-0,9	0,8-0,9	0,7-0,9
	oxidized	0,8-0,9	0,8-0,9	0,7-0,9	0,7-0,9
Tin	non oxidized	0,25	0,1-0,3	0,05	0,05
Titanium	polished	0,5-0,75	0,3-0,5	0,1-0,3	0,05-0,2
	oxidized		0,6-0,8	0,5-0,7	0,5-0,6
Wolfram	polished	0,35-0,4	0,1-0,3	0,05-0,25	0,03-0,1
Zinc	polished	0,5	0,05	0,03	0,02
	oxidized	0,6	0,15	0,1	0,1

Appendix B – Table of Emissivity for non-metals

Material	typical Emissivity				
	Spectral response	1,0 μm	2,2 μm	5,1 μm	8-14 μm
Asbestos		0,9	0,8	0,9	0,95
Asphalt				0,95	0,95
Basalt				0,7	0,7
Carbon	non oxidized		0,8-0,9	0,8-0,9	0,8-0,9
	graphite		0,8-0,9	0,7-0,9	0,7-0,8
Carborundum			0,95	0,9	0,9
Ceramic		0,4	0,8-0,95	0,8-0,95	0,95
Concrete		0,65	0,9	0,9	0,95
Glass	plate		0,2	0,98	0,85
	melt		0,4-0,9	0,9	
Grit				0,95	0,95
Gypsum				0,4-0,97	0,8-0,95
Ice					0,98
Limestone				0,4-0,98	0,98
Paint	non alkaline				0,9-0,95
Paper	any color			0,95	0,95
Plastic >50 μm	non transparent			0,95	0,95
Rubber				0,9	0,95
Sand				0,9	0,9
Snow					0,9
Soil					0,9-0,98
Textiles				0,95	0,95
Water					0,93
Wood	natural			0,9-0,95	0,9-0,95

Appendix C – Smart Averaging

The average function is generally used to smoothen the output signal. With the adjustable parameter time this function can be optimal adjusted to the respective application. One disadvantage of the average function is that fast temperature peaks which are caused by dynamic events are subjected to the same averaging time. Therefore those peaks can only be seen with a delay on the signal output.

The function **Smart Averaging** eliminates this disadvantage by passing those fast events without averaging directly through to the signal output.

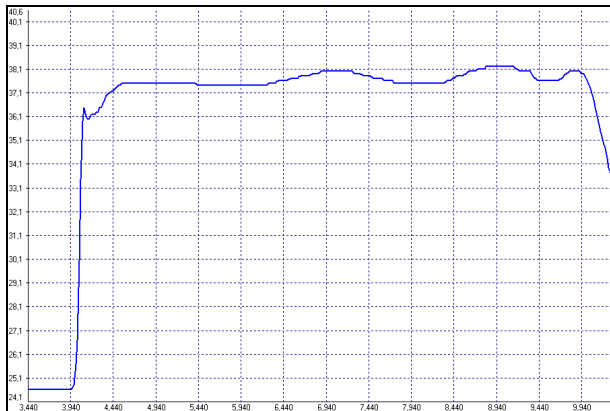

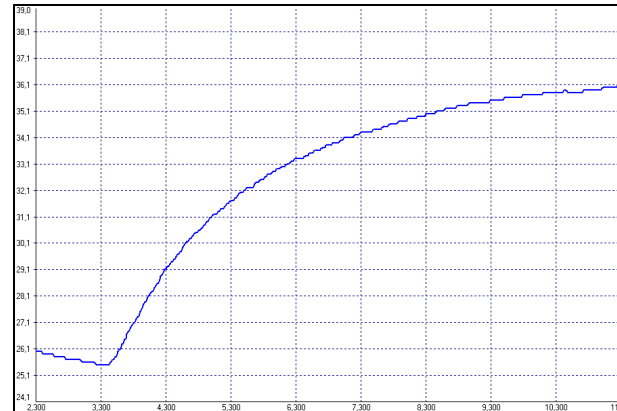

Signal graph with Smart Averaging function



Signal graph without Smart Averaging function

Appendix D – Declaration of Conformity

EG-Konformitätserklärung EU Declaration of Conformity	
Wir / We	Optris GmbH Ferdinand Buisson Str. 14 D-13127 Berlin
erklären in alleiniger Verantwortung, dass declare on our own responsibility that	die Produktserie optris CT the product group optris CT
den Anforderungen der EMV-Richtlinie 2014/30/EU und der Niederspannungsrichtlinie 2014/35/EU entspricht. meets the provisions of the EMC Directive 2014/30/EU and the Low Voltage Directive 2014/35/EU.	
Angewandte harmonisierte Normen: Applied harmonized standards:	
EMV Anforderungen / EMC General Requirements:	
EN 61326-1:2013 (Grundlegende Prüfanforderungen / Basic requirements)	
EN 61326-2-3:2013	
Gerätesicherheit von Messgeräten / Safety of measurement devices:	
EN 61010-1:2010	
EN 60825-1:2015 (Lasersicherheit / Laser safety)	
Dieses Produkt erfüllt die Vorschriften der Richtlinie 2011/65/EU (RoHS) des Europäischen Parlaments und des Rates vom 8. Juni 2011 zur Beschränkung der Verwendung bestimmter gefährlicher Stoffe in Elektro- und Elektronikgeräten. This product is in conformity with Directive 2011/65/EU (RoHS) of the European Parliament and of the Council of 8 June 2011 on the restriction of the use of certain hazardous substances in electrical and electronic equipment.	
Berlin, 04.11.2015	Dr. Ulrich Kienitz Geschäftsführer / General Manager
Ort, Datum / place, date	

optris CT-MA-E2019-01-A