

# Torque Measuring Flange

Type 4510B...

## Dual-Range Sensor, Assembly with Clamping Set

Torque measuring flanges Type 4510B... measure torque by strain gages. The digital measuring values are transmitted contactless from rotor to stator. There are analog and digital output signals available for evaluation.

- Rated torque: 100 ... 20 000 N·m
- Ratio for second range: 1:10 or 1:5 of rated torque
- Speed ranges up to 12 000 1/min
- Accuracy class in standard measuring range: 0,2  
In the extended measuring range: 0,4
- Integral speed sensor with 60 pulses/revolution
- Maintenance-free, bearingless
- Flange and hub solution
- Digital non-contact signal transmission
- Electrical control signal
- Active temperature compensation
- Calibrated RS-232C output

### Options

- Second separately calibrated measuring range 1:5 or 1:10
- Frequency output

### Description

Due to the design with clamping set the torque measuring flange may be mounted directly on the shaft of the loading machine. The clamping set is in the scope of delivery. Adaption on the measuring side is done by means of a flange. Measuring flanges Type 4510B... are very robust and largely insensitive to bending moment and transverse forces.

The optional dual range version is predestinated for applications with high peak torque and medium average operating torque. A single range torque sensor should be selected for withstanding the peak torque. For measuring the average operating torque it would therefore be oversized.

### Application

- Gear box test rigs
- Wheel load simulation
- Engine test rigs

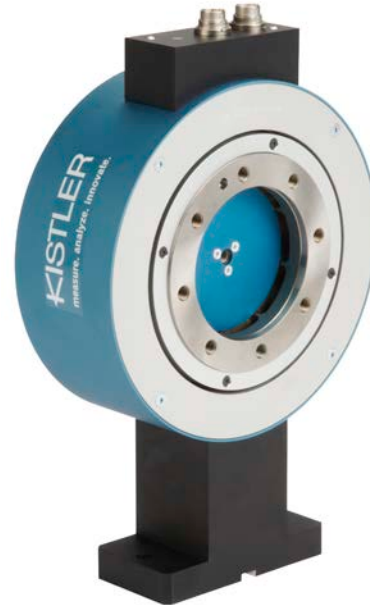

### General Electrical Specifications

Output signal option B1 at $M_{nom}$ (rated value)	VDC	$\pm 0 \dots 10$
	VDC	10
Output signal option B2 at $M_{nom}$ (rated value)	kHz	$100 \pm 40$
	kHz	140 (40)
Load resistance	k $\Omega$	$> 10$
Limit frequency -3 dB	kHz	1
100 % control input	VDC	"On" 3,5 ... 30 "Off" 0 ... 2
Control signal	% FSO	$100 \pm 0,1$
Supply voltage	VDC	11 ... 30
Power consumption	W	$< 5$

### Electrical Measuring Data

Zero point stability (for 24 h)	% FSO	0,03
Reference temperature	$^{\circ}\text{C}$	$22 \pm 2$
Operating temperature range (Rated temperature range)	$^{\circ}\text{C}$	10 ... 60
Service temperature range	$^{\circ}\text{C}$	0 ... 70
Storage temperature range	$^{\circ}\text{C}$	-25 ... 80

4510B\_000-737e-10.13

## Technical Data

### Mechanical Basic Data

Type 4510B...			100	200	500	1k2	1k3	2k0	4k0	10k	20k
Rated torque	$M_{nom}$	N·m	100	200	500	1 000	1 000	2 000	4 000	10 000	20 000
Measuring range		N·m	100	200	500	1 000	1 000	2 000	4 000	10 000	20 000
Max. load clamping set		N·m	570	570	2 400	2 400	4 060	4 060	10 400	26 500	44 000
Limiting torque	$M_{op}$	N·m	265	400	1 300	1 800	1 800	3 000	7 500	16 000	30 000
Rupture torque	$M_{rupt}$	N·m	>400	>800	>2 000	>4 000	>4 000	>8 000	>16 000	>40 000	>80 000
Alternating torque	$M_{dyn}$	N·m	100	200	500	1 000	1 000	2 000	4 000	10 000	20 000
Nominal speed	$n_{nom}$	1/min	12 000	12 000	9 000	9 000	9 000	9 000	9 000	4 000	4 000
Torsional rigidity	$C_T$	kN·m/rad	125	290	417	1 316	1 587	2 597	5 333	21 277	27 397
Rotation angle at $M_{nom}$	$\varphi$	°	0,046	0,04	0,069	0,044	0,036	0,044	0,043	0,027	0,042
Max. bending torque	$M_B$	N·m	1 600	1 600	1 700	1 700	5 000	5 000	8 500	18 000	18 000
Longitudinal force	$F_A$	kN	22	20	54	78	116	84	212	379	475
Max. radial force	$F_Q$	kN	3	3	8	8	12	15	20	30	40
Rotor weight	$m_{rotor}$	kg	4,4	4,4	7,7	7,8	10	10	12	36	41,8
Stator weight	$m_{stator}$	kg	3,6	3,6	4,4	4,4	4,4	4,4	4,4	2,3	2,8
Moment of inertia (rotor)	$j_{rotor}$	kg·m <sup>2</sup> ·10 <sup>-3</sup>	11,4	11,5	31	31,2	39,3	39,4	55,3	374	495
Partial mass of the rotor (measurement side)	$m_{rotor-M}$	kg	2,2	2,2	2,9	2,9	3,7	3,7	3,8	7,4	7,4
Partial moment of inertia of the rotor (measurement side)	$j_{rotor-M}$	kg·m <sup>2</sup> ·10 <sup>-3</sup>	8,2	8,2	20,1	20,2	21,8	21,8	21,9	90,8	90,8
Balancing class	Q		6,3								
Housing material			Hard anodized aluminum								
Protection class			IP54								

### Electrical Measuring Data – Standard Measuring Range 1:1

Rated torque	N·m	100 ... 4 000	10 000 ... 20 000
Accuracy class		0,2	0,2
Linearity error including hysteresis	%FSO	<±0,1	<±0,2
Temp. influence on the zero point	%FSO/10 °C	<±0,2	<±0,2
Temp. influence on the nominal value	%FSO/10 °C	<±0,2	<±0,2

### Electrical Measuring Data – Second Measuring Range 1:10, 1:5 (Option A1, A2)

Rated torque	N·m	100 ... 4 000
Accuracy class		0,4
Linearity error including hysteresis	%FSO	<±0,2
Temp. influence on the zero point	%FSO/10 °C	<±0,4
Temp. influence on the nominal value	%FSO/10 °C	<±0,4

### Electrical Measuring Data – Speed

Pulses/revolution		1x60
Output signal	V	5 (TTL)

4510B\_000-737e-10.13

**Dimensions**

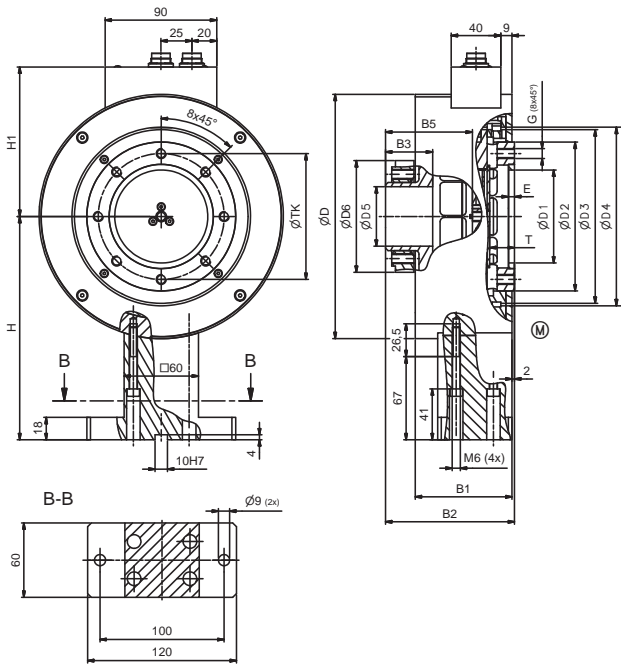

Fig. 1: Type 4510B... size 1 and 3,  
100 N-m, 200 N-m, 1 000 N-m, 2 000 N-m, 4 000 N-m

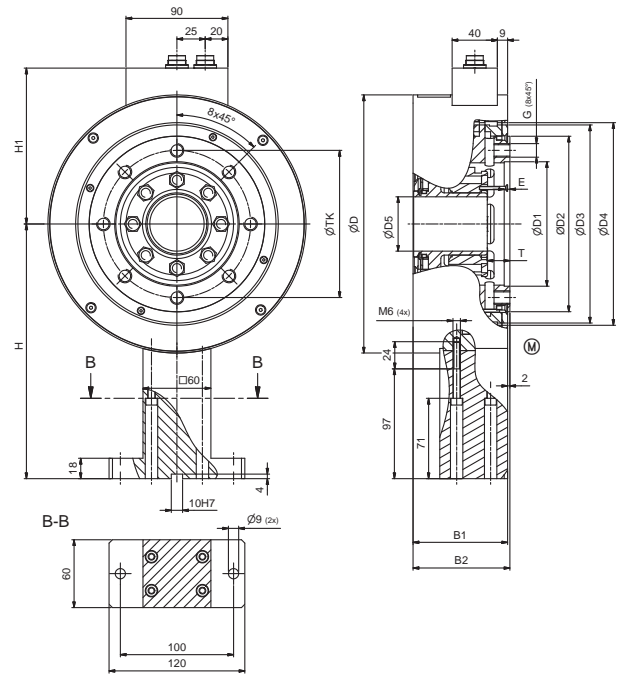

Fig. 2: Type 4510B... size 2,  
500 N-m and 1 000 N-m (M) = Measuring end

**Dimensions in mm**

Size	Measuring range N-m	ØD	ØD1 <sub>H7</sub>	ØD2	ØD3	ØD4	ØD5 <sub>G5</sub>	ØD6	B1	B2	B3	B4 <sup>2)</sup>	B5	T	E	TKø	G	H	H1
1	100	197	75	120	140	144	48	90	78	104	38	68	70	20	5	101,5	M8	180	120,5
1	200	197	75	120	140	144	48	90	78	104	38	68	70	20	5	101,5	M8	180	120,5
2	500	228	110	155	175	179	48	-	83,5	85,5	65	-	-	20	5	130	M12	225	137,7
2	1 000	228	110	155	175	179	48	-	83,5	85,5	65	-	-	20	5	130	M12	225	137,7
3	1 000	228	110	155	175	179	65	141	83,5	123	57	86	88	19	5	130	M12	225	137,7
3	2 000	228	110	155	175	179	65	141	83,5	123	57	86	88	19	5	130	M12	225	137,7
3	4 000	228	110	155	175	179	80	170	83,5	132	64	93	95	19	5	130	M12	225	137,7

4510B\_000-737e-10.13

**Dimensions**

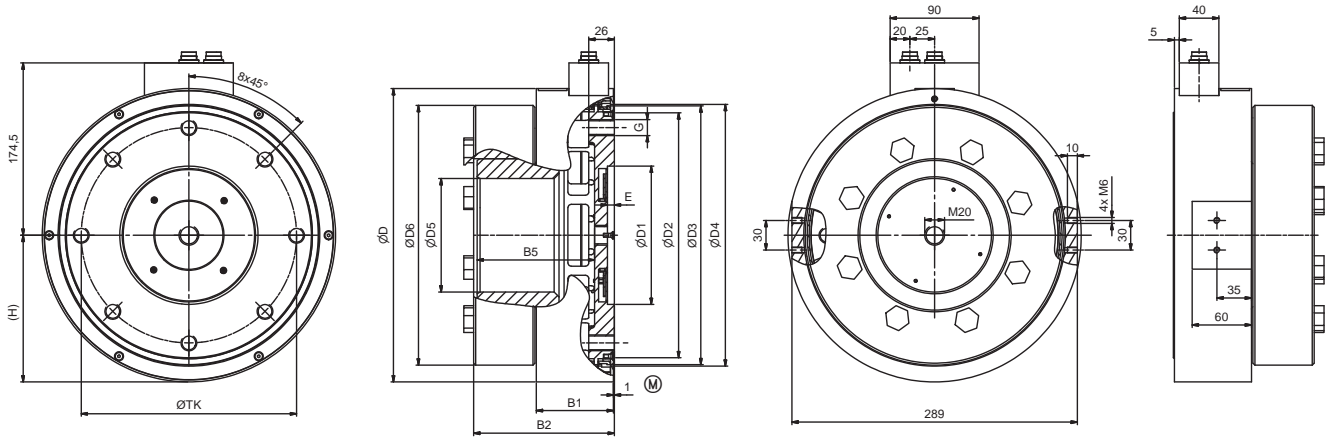

Fig. 3: Type 4510B... size 4, 10k

(M) = Measuring end

**Dimensions in mm**

Size	Measuring range N·m	øD	øD1 H7	øD2	øD3	øD4	øD5 G5	øD6 g6	B1	B2	B5	E	TKø	G	H
4	10 000	297	140	250	262	165	115	263	79	142,5	119	7	218	M16	148,5

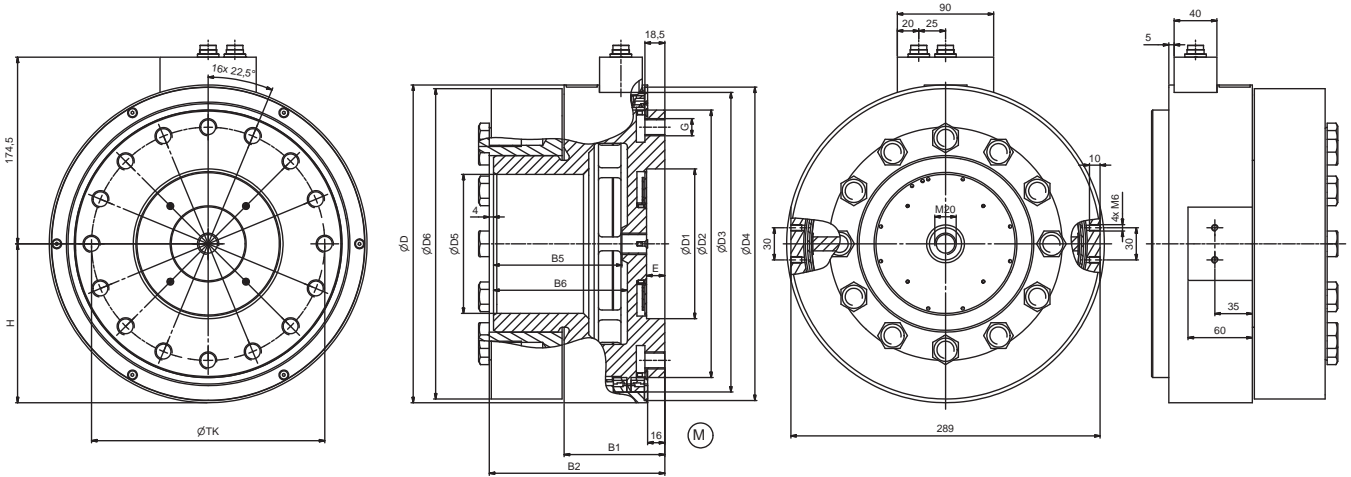

Fig. 4: Type 4510B... size 5, 20k

(M) = Measuring end

**Dimensions in mm**

Size	Measuring range N·m	øD	øD1 H7	øD2	øD3	øD4	øD5 G5	øD6	B1	B2	B4 <sup>2)</sup>	B5	B6	E	TKø	G	H
5	20 000	297	140	250	280	293	130	290	94	164	118	120	125	17	218	M16	148,5

4510B\_000-737e-10.13

**Electrical Connections**

**Pin Allocation of the 12-Pin Built-in Standard Connector A**

	Function	PIN	Description
Supply	F	+U <sub>B</sub>	11 ... 30 VDC, power consumption <5 W
	A	GND	Ground relating to +U <sub>B</sub>
Shield	M		In sensor connected to housing
Torque output	C	U <sub>A</sub>	Voltage output B1 ±10 VDC bei ±M <sub>Norm</sub> at >2 kΩ 10 VDC at control signal activation R <sub>i,c</sub> = 10 Ω, output short circuit
	D	AGND	Ground relating to U <sub>A</sub>
Speed pulses	H	Track A	Active, TTL-level
	G		Not connected
	J		Not connected
100 % Control input	K	Control	Off: 0 ... 2 VDC On: 3,5 ... 30 VDC R <sub>i,k</sub> = 10 kΩ
	B	TXD	Serial send path of the torque sensor
RS-232C interface to the CoMo Torque	L	RXD	Serial receive path of the torque sensor
	E	DGND	Ground relating to speed pulses, calibration/control input, RS-232C interface

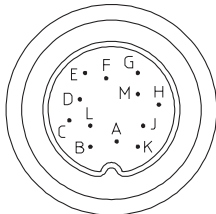

**Pin Allocation of the 7-Pin Built-in Standard Connector B**

	Function	PIN	Description
Measuring range selection	1	Gain	Normal (1:1) with 0 ... 2 VDC Extended (1:5 / 1:10) with 3,5 ... 30 VDC
	2		For company internal functions, don't use!
Digital mass potential	3	DGND	Ground relating to RS-232C interface
100 % control input	4	Control	Off: 0 ... 2 VDC On: 3,5 ... 30 VDC
	5	TXD	Serial send path of the torque sensor
RS-232C interface	6	RXD	Serial receive path of the torque sensor
	7	OGND	Ground relating for control

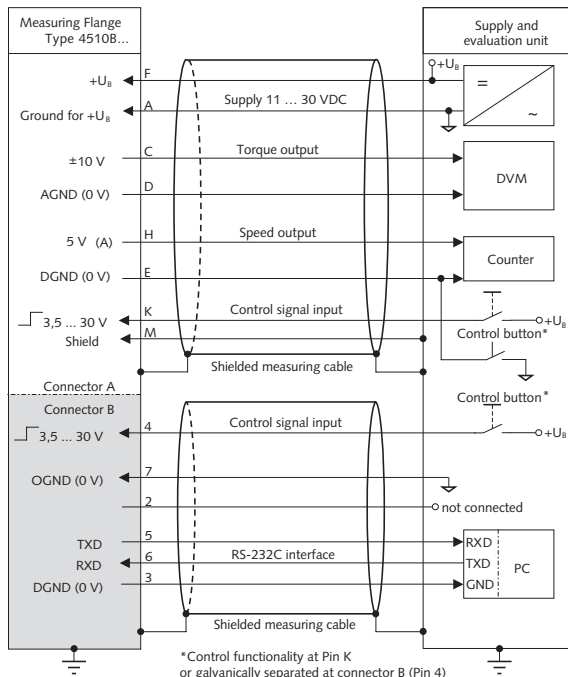
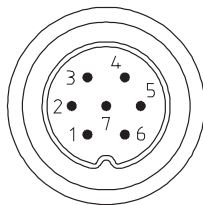

Fig. 5: Pin allocation of the built-in connector A and B (standard)

4510B\_000-737e-10.13

**Mounting**

**Connection of Rotor, Fastening Bolts**

Nominal torque $M_{nom}$	N·m	100	200	500	1 000 1k2	1 000 1k3	2 000	4 000	10 000	20 000	
Size		BG 1		BG 2		BG 3		BG 4	BG 5		
Thread		M8	M8	M12	M12	M12	M12	M12	M16	M16	
Quality class		8.8	8.8	8.8	8.8	8.8	12.9	12.9	12.9	12.9	
Min. mounting depth	mm	6	8	13	13	13	16	16	18,5	26	
Max. mounting depth	mm	20	20	20	20	20	20	20	45	45	
Fastening torque $M_{Anz}$ – Flange	N·m	23	23	80	80	80	137	137	370	370	
Fastening torque clamping set	N·m	12	12	35	35	58	58	70	160	295	
Balancing class	Q							6,3			
Counterflange flatness	mm							0,01			
Counterflange concentricity	mm							0,02			
Max. offset rotor to stator:											
Axial	mm							±1			
Radial	mm							±1			

**Important: Retraction depth has to be strictly observed (Dimension B4)!**

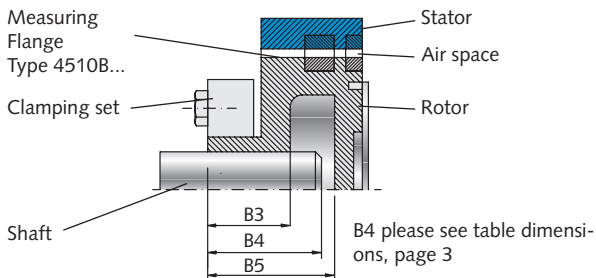

Fig. 6: Schematic diagram of the retraction depth

**Application Examples**

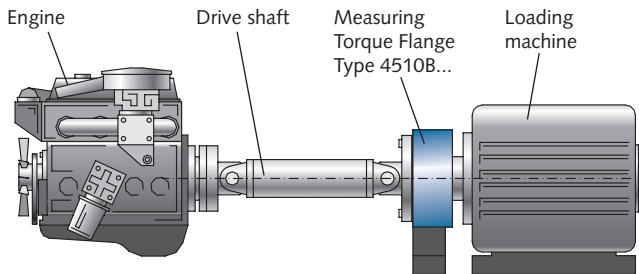

Fig. 7: Combustion engine front machine test stand

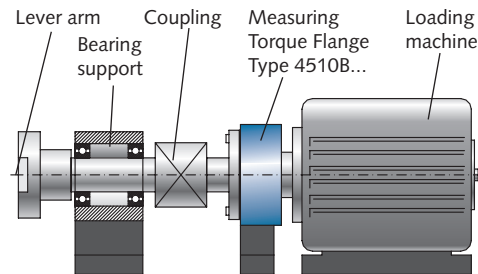

Fig. 8: Calibration facility

**Mechanical Mounting**

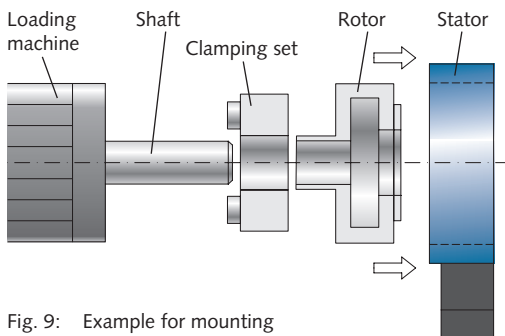

Fig. 9: Example for mounting

4510B\_000-737e-10.13

**Included Accessories**

- None

**Optional Accessories**

- |  |                                   |
|--|-----------------------------------|
| • Connection cable, length 5 m   | <b>Type/Art. No.</b><br>KSM007203 |
| • Connection cable, length 5 m,<br>12 pin – open ends                    | KSM124970-5                       |
| • Connection cable, length 5 m,<br>7 pin – open ends                     | KSM219710-5                       |
| • Connection cable, length 2,5 m,<br>12 pin – CoMo Torque                | KSM186420-2,5                     |
| • Female connector 7 pin (plug C)  | KSM000517                         |
| • Female connector 8 pin (plug D)  | KSM013136                         |
| • ControlMonitor CoMo Torque<br>Evaluation instrument for torque sensors | 4700B...                          |
| • Adapter flanges  | 2300A...                          |
| • Torsion proof multi-disk couplings                                     | 2300A...                          |
| • SensorTool   | 4706A                             |

Our torque calibration service lab DKD-K-37701 offers traceable recalibration of any brands.

For further information of cable and connector see data sheet 000-615.

**Ordering Key****Measuring Ranges in N·m**

100	Size 1	<b>100</b>
200	Size 1	<b>200</b>
500	Size 2	<b>500</b>
1 000	Size 2	<b>1k2</b>
1 000	Size 3	<b>1k3</b>
2 000	Size 3	<b>2k0</b>
4 000	Size 3	<b>4k0</b>
10 000 <sup>1)</sup>	Size 4	<b>10k</b>
20 000 <sup>1)</sup>	Size 5	<b>20k</b>

**Range Selection**

Without	<b>A0</b>
Dual range sensor, rated torque 1:10 (Measuring range selection)	<b>A1</b>
Dual range sensor, rated torque 1:5 (Measuring range selection)	<b>A2</b>

**Output Signal**

Analog output ±10 VDC	<b>B1</b>
Frequency output 100 ±40 kHz	<b>B2</b>

**Increased Accuracy**

Without	<b>0</b>
---------	----------

<sup>1)</sup> no range selection A1 and A2 possible

Type 4510B    **Order Example:****Type 4510B100A0B10**

Measuring torque flange: Rated torque **100** N·m, without range selection: **A0**, Analog output ±10 VDC: **B1**, without increased accuracy: **0**