

optris[®] CSmicro

LT/ 2WLT/ 2W2M/ 3M

Infrared Thermometer



Operators manual

 **optris**
infrared thermometers



Messtechnik Schaffhausen GmbH

Mühlenstrasse 4, CH-8260 Stein am Rhein

Telefon +41 52-672 50 00

Telefax +41 52-672 50 01

www.mts.ch, e-mail: info@mts.ch

Messen Prüfen Automatisieren www.mts.ch



References to other chapters are marked as [► ...].

Warranty

Each single product passes through a quality process. Nevertheless, if failures occur please contact the customer service at once. The warranty period covers 24 months starting on the delivery date. After the warranty is expired the manufacturer guarantees additional 6 months warranty for all repaired or substituted product components. Warranty does not apply to damages, which result from misuse or neglect. The warranty also expires if you open the product. The manufacturer is not liable for consequential damage or in case of a non-intended use of the product. If a failure occurs during the warranty period the product will be replaced, calibrated or repaired without further charges. The freight costs will be paid by the sender. The manufacturer reserves the right to exchange components of the product instead of repairing it. If the failure results from misuse or neglect the user has to pay for the repair. In that case you may ask for a cost estimate beforehand.

Content

	Page		Page
Description	3	Maximum Loop Impedance [2W]	40
Scope of Supply	3	Digital Mode	41
Maintenance	3	Alarm Output	43
Cautions	4	Software CompactConnect	44
Model Overview	4	Installation	44
Factory Default Settings	5	Communication Settings	45
Technical Data	9	Digital Command Set	46
General Specifications	9	Basics of Infrared Thermometry	48
Electrical Specifications	10	Emissivity	49
Pin Configuration	12	Definition	49
Measurement Specifications	13	Determination of unknown Emissivities	49
Optical Charts	16	Characteristic Emissivities	50
CF Lens and Protective Window	26	Appendix A – Emissivity Table Metals	51
LED Functions	28	Appendix B – Emissivity Table Non Metals	53
Automatic Aiming Support	28	Appendix C – Smart Averaging	54
Self Diagnostic	29	Appendix D – Direct Connection to an RS232 interface	55
Temperature Code Indication	30	Appendix E – Declarations of Conformity	56
Mechanical Installation	31		
Mounting Accessories [LT/ 3M/ 2WLT/ 2W2M]	32		
Mounting Accessories [2WhsLT]	33		
Air Purge Collars [LT/ 3M/ 2WLT/ 2W2M]	34		
Air Purge Collar [2WhsLT]	35		
Further Accessories	36		
Electrical Installation	38		
Analog Mode	38		

Description

The sensors of the optris CSmicro series are noncontact infrared thermometers.

They calculate the surface temperature based on the emitted infrared energy of objects [**► Basics of Infrared Thermometry**].

The sensor housing of the optris CSmicro is made of stainless steel (IP65/ NEMA-4 rating) – the sensor electronics is integrated inside the connection cable.

Read the manual carefully before the initial start-up. The producer reserves the right to change the herein described specifications in case of technical advance of the product.

Scope of Supply

- CSmicro incl. connection cable
- Mounting nut
- Operators manual

Maintenance

Lens cleaning: Blow off loose particles using clean compressed air. The lens surface can be cleaned with a soft, humid tissue moistened with water or a water based glass cleaner.

PLEASE NOTE: Never use cleaning compounds which contain solvents (neither for the lens nor for the housing).

Cautions

Avoid abrupt changes of the ambient temperature.

In case of problems or questions which may arise when you use the sensor, please contact our service department.

The sensors CSmicro are sensitive optical systems. Please use only the thread for mechanical installation. Avoid mechanical violence on the head – this may destroy the system (expiry of warranty).

Model Overview

The sensors of the CSmicro series are available in the following versions:

Series	Models	Measurement range	spectral response	Output	Optics	Specialty
LT	LT15	-40 to 1030 °C	8-14 µm	0-5/ 10 V	15:1	
	LT02	-40 to 1030 °C	8-14 µm	0-5/ 10 V	2:1	
3M	3ML	50...350 °C	2,3 µm	0-5/ 10 V	22:1	
	3MH	100 to 600 °C	2,3 µm	0-5/ 10 V	33:1	
2WLT	2W LT15	-40 to 1030 °C	8-14 µm	4-20 mA	15:1	
	2W LT15H	-40 to 1030 °C	8-14 µm	4-20 mA	15:1	T _{amb} max. 180 °C
	2W LT22H	-40 to 1030 °C	8-14 µm	4-20 mA	22:1	T _{amb} max. 180 °C
	2W hsLT	-20 to 150 °C	8-14 µm	4-20 mA	15:1	0,025 K resolution
2W2M	2W 2ML	250 to 800 °C	1,6 µm	4-20 mA	40:1	
	2W 2MH	385 to 1600 °C	1,6 µm	4-20 mA	75:1	

Factory Default Settings

The units have the following presetting at time of delivery:

CSmicro	LT15/ LT02	3ML	3MH
Temperature range:	0...350 °C	50...350 °C	100...600 °C
Output:	0...3,5 V	0...5 V	0...5 V
Emissivity:	0,950	0,950	0,950
Transmission:	1,000	1,000	1,000
Average time:	0,3 s	0,1 s	0,1 s
Smart averaging:	active	active	active
Smart Averaging hysteresis:	2 °C	2 °C	2 °C
Ambient temperature source:	internal (head)		
Status-LED function:	Self diagnostic		
Input (IN/ OUT/ green):	inactive		
Output (OUT/ yellow):	mV output		
Vcc adjust:	inactive		
Signal processing:	Hold mode: off		
Calibration:	Gain 1,000/ Offset 0,0		
Failsafe:	inactive		

CSmicro 2W	LT15	LT15H	LT22H	hsLT
Temperature range:	0...350 °C	0...500 °C	0...500 °C	-20...150 °C
Output:	4...20 mA	4...20 mA	4...20 mA	4...20 mA
Emissivity:	0,950	0,950	0,950	0,950
Transmission:	1,000	1,000	1,000	1,000
Average time:	0,3 s	0,3 s	0,3 s	0,3 s
Smart averaging:	active	active	active	active
Smart Averaging hysteresis:	2 °C	2 °C	2 °C	2 °C
Ambient temperature source:	internal (head)			
Status-LED function:	Self diagnostic			
Input (IN/ OUT/ green):	Communication input			
Output (OUT/ yellow):	Communication output			
Vcc adjust:	inactive			
Signal processing:	Hold mode: off			
Calibration:	Gain 1,000/ Offset 0,0			
Failsafe:	inactive			

CSmicro 2W	2ML	2MH
Temperature range:	250...800 °C	385...1600 °C
Output:	4...20 mA	4...20 mA
Emissivity:	1,000	1,000
Transmission:	1,000	1,000
Average time:	0,01 s	0,01 s
Smart averaging:	active	active
Smart Averaging hysteresis:	2 °C	2 °C
Ambient temperature source:	internal (head)	
Status-LED function:	Self diagnostic	
Input (IN/ OUT/ green):	Communication input	
Output (OUT/ yellow):	Communication output	
Vcc adjust:	inactive	
Signal processing:	Hold mode: off	
Calibration:	Gain 1,000/ Offset 0,0	
Failsafe:	inactive	

Smart Averaging means a dynamic average adaptation at high signal edges [activation/ deactivation via software only]. ► **Appendix C**

For a usage of the CSmicro LT for online maintenance applications (in electrical cabinets e.g.) the following recommend settings are already included in the factory default setting (but not active):

OUT

At **3-state output** the following settings are default:

Pre-alarm difference: 2 °C
No alarm level: 8 V
Pre-alarm level: 5 V
Alarm level: 0 V
Service voltage: 10 V

IN/ OUT:

At **Alarm output (open collector)** the following settings are default:

Mode: normally closed
Temp code output: activated (for values above alarm level)
Range settings: 0 °C = 0 %/ 100 °C = 100 %

Vcc adjust:

If **activated** the following settings are default:

Output voltage range: 0-10 V
Difference mode: activated

Alarm level	Alarm value (IN/ OUT pin)	Vcc
1	40 °C	11 V
2	45 °C	12 V
3	50 °C	13 V
4	55 °C	14 V
5	60 °C	15 V
6	65 °C	16 V
7	70 °C	17 V
8	75 °C	18 V
9	80 °C	19 V
10	85 °C	20 V

Technical Data

General Specifications

Environmental rating	IP65 (NEMA-4)	
Ambient temperature	Sensing head:	see: Measurement Specifications
	Electronics (inside cable):	-20...80 °C [LT/ 3M] -20...75 °C ¹⁾ [2W]
Storage temperature	-40...85 °C	
Relative humidity	10...95 %, non condensing	
Material	Stainless steel	
Dimensions	28 mm x 14 mm (head) [LT/ 3M/ 2WLT/ 2W2M] 55 mm x 29,5 mm (head incl. massive housing) [2WhsLT] 35 mm x 12 mm (electronics)	
Weight	42 g [LT/ 3M/ 2WLT/ 2W2M] 200 g [2WhsLT]	
Cable length	head – electronics	0,5 m (standard), 3 m, 6 m [LT/ 3M ²⁾ / 2WLT/ 2W2M]
	after electronics	0,5 m (standard), 3 m, [LT/ 3M/ 2WLT/ 2W2M]
	head – electronics	0,5 m [2WhsLT]
	after electronics	3,0 m [2WhsLT]
Cable diameter	2,8 mm (head – electronics) 4,3 mm (electronics – end of cable)	
Vibration	IEC 68-2-6: 3G, 11 – 200 Hz, any axis	
Shock	IEC 68-2-27: 50G, 11 ms, any axis	
Software	optional	

¹⁾ for V_{cc} (supply voltage) 5-12 VDC/ at V_{cc} > 12 VDC the max. ambient temperature of the electronics is 65 °C

²⁾ 6 m cable length not available for 3M version

Electrical Specifications

Used pin		Function	LT / 3M	2W
OUT	IN/ OUT			
x		Analog	0-5 V ¹⁾ or 0-10 V ²⁾ / scalable	4-20 mA/ scalable (current loop between Power and GND pin)
x		Alarm	output voltage adjustable; N/O or N/C	output current adjustable; N/O or N/C (current loop between Power and GND pin)
x		Alarm	3-state alarm output (three voltage level for no alarm, pre-alarm, alarm)	-
	x	Alarm	programmable open collector output [0-30 V DC/ 50 mA] ⁴⁾	programmable open collector output [0-30 V DC/ 500 mA]
	x	Temp. Code	Temp. Code Output (open collector) [0-30 V DC/ 50 mA] ⁴⁾	Temp. Code Output (open collector) [0-30 V DC/ 500 mA]
	x	Input	programmable functions: -external emissivity adjustment -ambient temperature compensation -triggered signal output and peak hold function ⁵⁾ -Reset of hold function ⁶⁾	programmable functions: -triggered signal output and peak hold function ⁵⁾ -Reset of hold function ⁷⁾
x	x	Serial digital ³⁾	uni- (burst mode) or bidirectional	uni- (burst mode) or bidirectional
Output impedances			min. 10 kΩ load impedance	max. 1000 Ω loop impedance
Current draw			9 mA	4-20 mA
Power supply			5...30 VDC	5...30 VDC

Status LED	green LED with programmable functions: <ul style="list-style-type: none">▪ alarm indication (threshold independent from alarm outputs)▪ automatic aiming support▪ self diagnostics▪ temperature code indication
Vcc adjust mode	10 adjustable emissivity and alarm values by variation of supply voltage/ Service mode for analog output [LT only]

¹⁾ 0...4,6 V at supply voltage 5 VDC; also valid for alarm output

²⁾ only at supply voltage ≥ 11 V

³⁾ inverted RS232, TTL, 9,6 kBaud

⁴⁾ 500 mA if the mV output is not used

⁵⁾ High level: $> 0,8$ V / Low level: $< 0,8$ V

⁶⁾ Reset of peak or valley hold by High level at IN/ OUT pin (Low: open or GND / High: $>2,4$ V...11 V)

⁷⁾ Reset of peak or valley hold by Low level at IN/ OUT pin (Low: GND / High: open or >1 V...11 V)

Pin Configuration

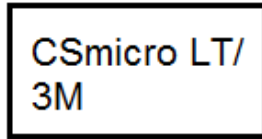

white
yellow
green
brown
black

Power
OUT
IN/ OUT
GND
Shield

Power supply
Analog output/ TxD/ Alarm output
Analog input/ RxD/ Open collector output
Ground (⊥)
Shield

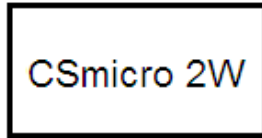

white
yellow
green
brown
black

Power
OUT
IN/ OUT
GND
Shield

Current loop (+)/ Alarm output
TxD
Trigger input/ RxD/ Open collector output
Current loop (-)/ Ground (⊥)
Shield

You will find a detailed description of the different sensor connections in chapter ► **Electrical Installation**.

Measurement Specifications

	LT15/ LT02	3ML	3MH
Temperature range IR (scalable via software)	-40...1030 °C	50...350 °C ⁴⁾	100...600 °C ⁴⁾
Ambient temperature (sensing head)	-20...120 °C	-20...85 °C	-20...85 °C
Spectral range	8...14 μm	2,3 μm	2,3 μm
Optical resolution	15:1/ 2:1	22:1	33:1
CF-lens (optional)	0,8 mm@ 10 mm/ 2,5 mm@ 23 mm	-	-
CF optics (built-in)	-	5,0 mm@ 110 mm	3,4 mm@ 110 mm
CF1 optics (built-in)	-	1,5 mm@ 30mm	1,0 mm@ 30 mm
Accuracy ¹⁾	±1,0 °C or ±1,0 % ²⁾	----- ±(0,3 % of reading + 2 °C) -----	-----
Repeatability ¹⁾	±0,5 °C or ±0,5 % ²⁾	----- ±(0,1 % of reading + 1 °C) -----	-----
Temperature coefficient ³⁾	±0,05 K/ K or ±0,05 %/ K (whichever is greater)		
Temperature resolution	0,1 K	0,1 K	0,1 K
Response time	30 ms (90 % signal)	25 ms (90 % signal)	25 ms (90 % signal)
Warm-up time	10 min	-	-
Emissivity/ Gain	0,100...1,100 (adjustable via software)		
Transmissivity	0,100...1,000 (adjustable via software)		
Interface (optional)	USB programming interface		
Signal processing	Average, Peak hold, Valley hold (adjustable via software)		

¹⁾ at ambient temperature 23±5 °C, whichever is greater; Epsilon = 1; Response time 1 s

²⁾ at object temperatures > 23 °C

³⁾ for ambient temperatures <18 °C and >28 °C

⁴⁾ T_{Object} > T_{Head}+25 °C

	<u>2WLT15</u>	<u>2WLT15H</u>	<u>2WLT22H</u>
Temperature range IR (scalable via software)	-40...1030 °C	-40...1030 °C	-40...1030 °C
Ambient temperature (sensing head)	-20...120 °C	-20...120 °C	-20...180 °C
Spectral range	8...14 µm	8...14 µm	8...14 µm
Optical resolution	15:1	15:1	22:1
CF-lens (optional)	0,8 mm@ 10 mm/	0,8 mm@ 10 mm	0,6 mm@ 10 mm
Accuracy ¹⁾	±1,0 °C or ±1,0 % ²⁾	±1,0 °C or ±1,0 % ²⁾	±1,0 °C or ±1,0 % ²⁾
Repeatability ¹⁾	±0,5 °C or ±0,5 % ²⁾	±0,5 °C or ±0,5 % ²⁾	±0,5 °C or ±0,5 % ²⁾
Temperature coefficient ³⁾	±0,05 K/ K or ±0,05 %/ K (whichever is greater)		
Temperature resolution	0,1 K	0,1 K	0,1 K
Response time	30 ms (90 % signal)	150 ms (90 % signal)	150 ms (90% signal)
Warm-up time	10 min	10 min	10 min
Emissivity/ Gain	0,100...1,100 (adjustable via software)		
Transmissivity	0,100...1,000 (adjustable via software)		
Interface (optional)	USB programming interface		
Signal processing	Average, Peak hold, Valley hold (adjustable via software)		

¹⁾ at ambient temperature 23±5 °C, whichever is greater; Epsilon = 1; Response time 1 s

²⁾ at object temperatures > 23 °C

³⁾ for ambient temperatures <18 °C and >28 °C

	2WhsLT	2W2ML	2W2MH
Temperature range IR (scalable via software)	-20...150 °C	250...800 °C	385...1600 °C
Ambient temperature (sensing head)	-20...75 °C	-20...125 °C	-20...125 °C
Spectral range	8...14 µm	1,6 µm	1,6 µm
Optical resolution	15:1	40:1	75:1
Accuracy ¹⁾	±1 °C or ±1 % ³⁾	----- ±(0,3 % of reading + 2 °C) ²⁾	-----
Repeatability ¹⁾	±0,3 °C or ±0,3 % ³⁾	----- ±(0,1 % of reading + 1 °C) ²⁾	-----
Temperature coefficient ⁵⁾	±0,05 K/ K or ±0,05 %/ K (whichever is greater)		
Temperature resolution	0,025 K ^{3) 4)}	0,1 K ⁴⁾	0,1 K ⁴⁾
Response time	150 ms (90 % signal)	10 ms (90 % signal)	10 ms (90 % signal)
Warm-up time	10 min	-	-
Emissivity/ Gain	0,100...1,100 (adjustable via software)		
Transmissivity	0,100...1,000 (adjustable via software)		
Interface (optional)	USB programming interface		
Signal processing	Average, Peak hold, Valley hold (adjustable via software)		

¹⁾ at ambient temperature 23±5 °C; Epsilon = 1; Response time = 1 s

²⁾ at object temperatures > 450 °C

³⁾ at object temperatures > 20 °C

⁴⁾ at time constants > 0,2 s

⁵⁾ for ambient temperatures <18 °C and >28 °C

Optical Charts

The following optical charts show the diameter of the measuring spot in dependence on the distance between measuring object and sensing head. The spot size refers to 90 % of the radiation energy. The distance is always measured from the front edge of the sensor housing/ CF-lens holder/ air purge.

The size of the measuring object and the optical resolution of the infrared thermometer determine the maximum distance between sensing head and measuring object. In order to prevent measuring errors the object should fill out the field of view of the optics completely. Consequently, the spot should at all times have at least the **same size like** the object or should be **smaller than** that.

D = Distance from front of the sensing head to the object

S = Spot size

The D:S ratio is valid for the focus point.

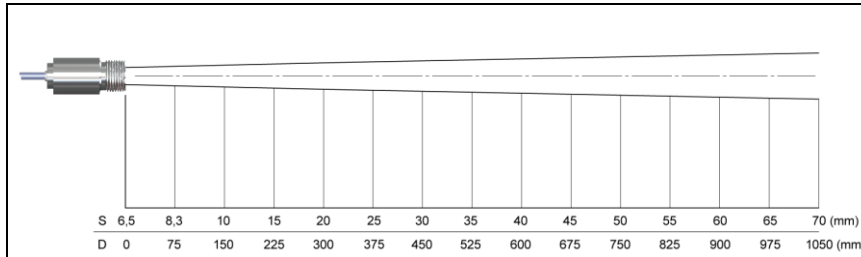

LT15/ 2WLT15/ 2WLT15H/ 2WhsLT D:S = 15:1

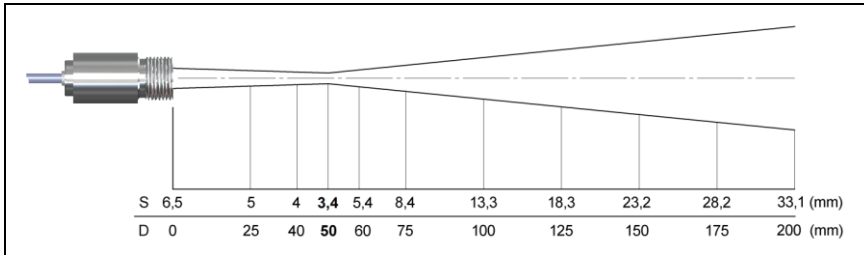

LT15CF/ 2WLT15CF/ 2WLT15HCF D:S = 15:1/ D:S Far field = 5:1

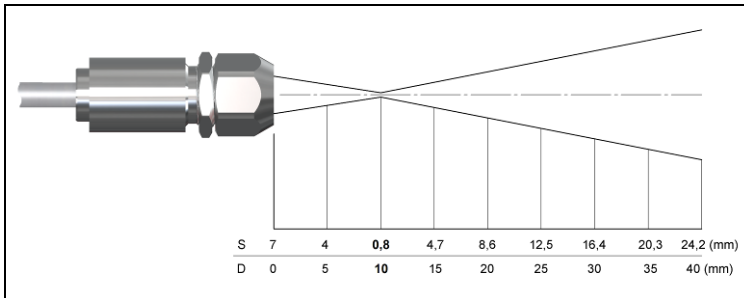

LT15/ 2WLT15/ 2WLT15H/ 2WhsLT with CF lens (0,8 mm @ 10 mm)/ D:S Far field = 1,4:1

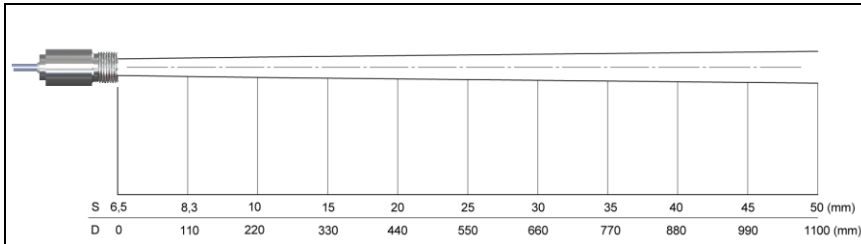

2WLT22H D:S = 22:1

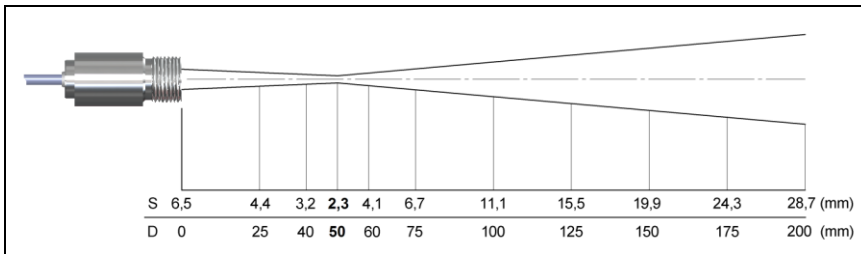

LT22CF/ 2WLT22HCF D:S = 22:1/ D:S Far field = 6:1

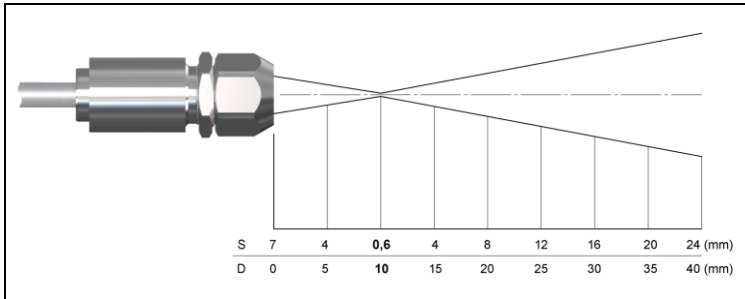

2WLT22H with CF lens (0,6 mm@ 10 mm)/ D:S Far field = 1,5:1

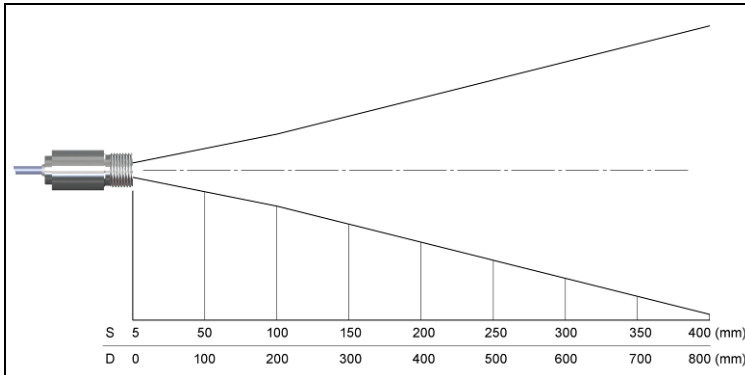

LT02/ 2WLT02 D:S = 2:1

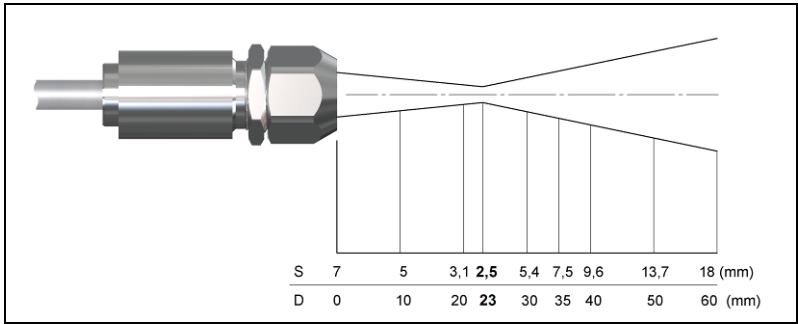

LT02/ 2WLT02 with CF lens (2,5 mm@ 23 mm)/ D:S Far field = 2,5:1

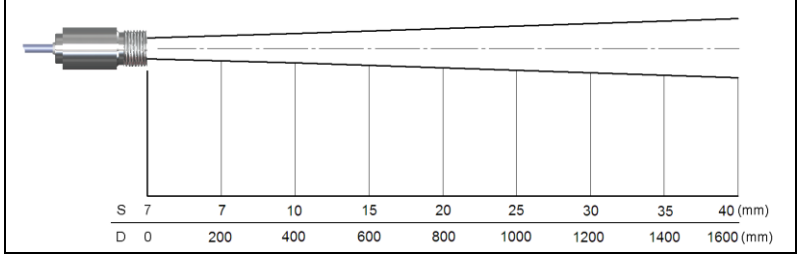

2W2ML SF D:S = 40:1

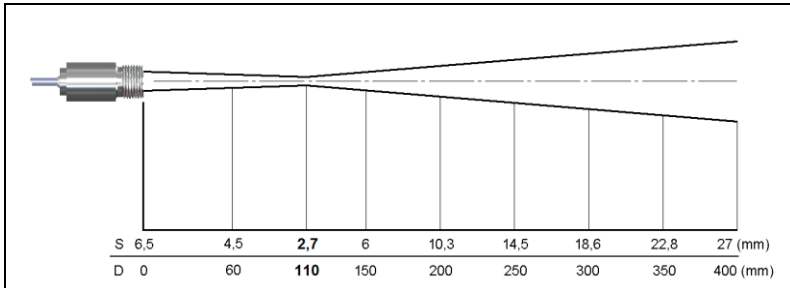

2W2ML CF D:S = 40:1/ D:S Far field = 12:1

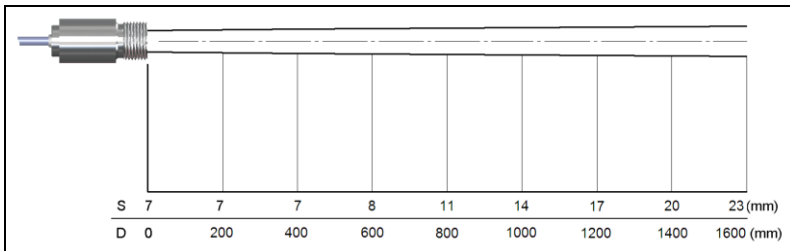

2W2MH SF D:S = 75:1

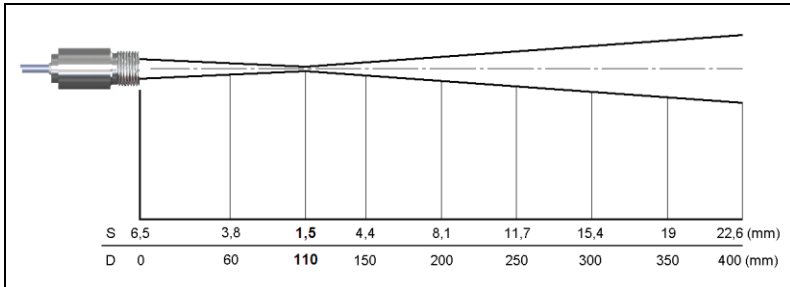

2W2MH CF D:S = 75:1/ D:S Far field = 14:1

If the CF lens (ACCTCFHT or ACCTCFHTE) is used in connection with 2W2M units (SF or CF optics) the focus is shifted to a distance of 11 mm.

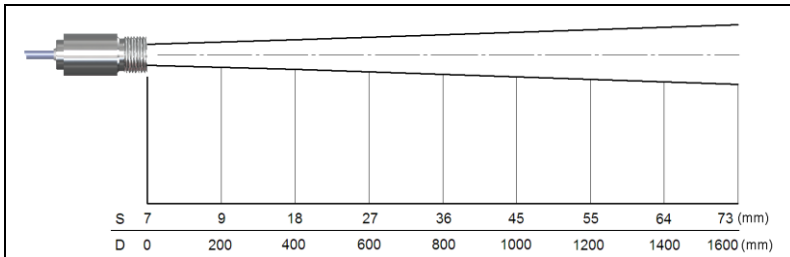

3ML SF D:S = 22:1

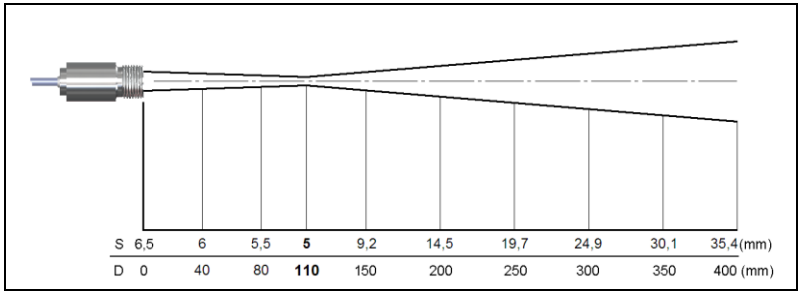

3ML CF D:S = 22:1/ D:S Far field = 9:1

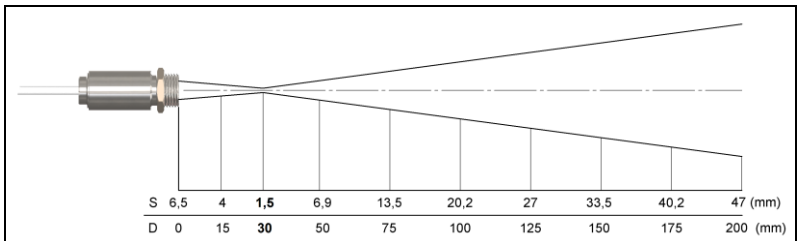

3ML CF1 D:S = 22:1/ D:S Far field = 3,5:1

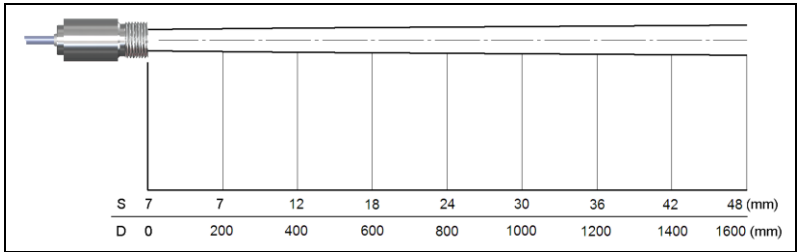

3MH SF D:S = 33:1

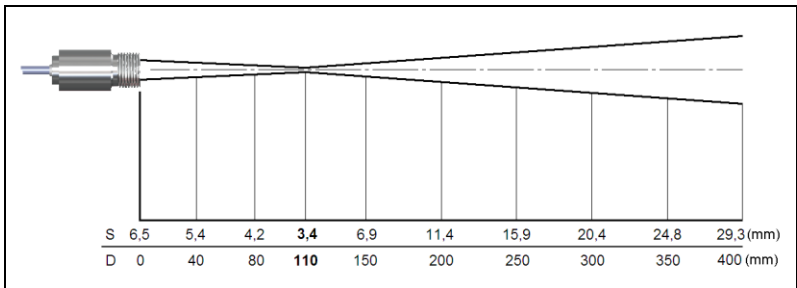

3MH CF D:S = 33:1 / D:S Far field = 11:1

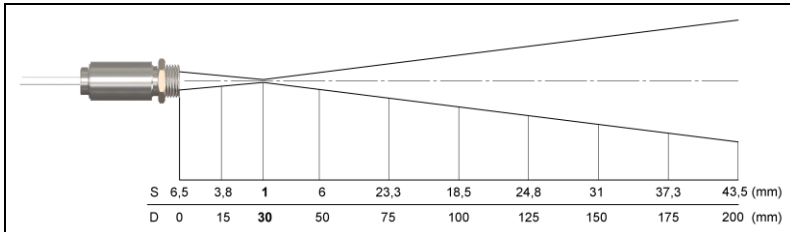

3MH CF1 D:S = 33:1/ D:S Far field = 4:1

CF Lens and Protective Window

The optional CF lens allows the measurement of very small objects. The minimum spot size depends on the used sensing head. The distance is always measured from the front edge of the CF lens holder or laminar air purge collar. The installation on the sensing head will be done by turning the CF lens until end stop. To combine it with the 2W_hLT model please use the version with external thread M12x1.

Versions Overview:

ACCTCF	CF lens for installation on sensing head [LT/ 2WLT]
ACCTCFHT	CF lens for installation on sensing head [2W2M]
ACCTCFE	CF lens with external thread for installation in massive housing [LT/ 2WLT]
ACCTCFHTE	CF lens with external thread for installation in massive housing [2W2M]

For protection of the sensing head optics a protective window is available. The mechanical dimensions are equal to the CF lens. It is available in the following versions:

ACCTPW	Protective window for installation on sensing head [LT/ 2WLT]
ACCTPWHT	Protective window for installation on sensing head [2W2M]
ACCTPWE	Protective window with external thread for installation in massive housing [LT/ 2WLT]
ACCTPWHT E	Protective window with external thread for installation in massive housing [2W2M]

Transmission values if the CF lens is used (average values):

LT	0,78
2M	0,87
3M	0,92

Transmission values if the protective window is used (average values):

LT	0,83
2M/ 3M	0,93

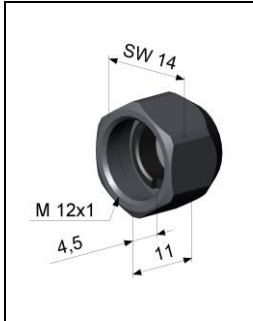

**CF lens:
ACCTCF/ ACCTCFHT
Protective window:
ACCTPW/ ACCTPWHT**

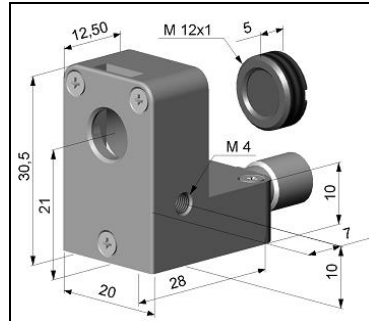

**Laminar air purge with integrated
CF lens:
ACCTAPLCF/ ACCTAPLCFHT**

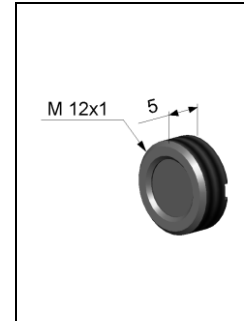

**CF lens with external thread:
ACCTCFE/ ACCTCFHTE
Protective window with external
thread:
ACCTPWE/ ACCTPWHT**

To change the transmission value the optional USB-Kit (including software) is necessary.

LED Functions

The green LED can be programmed for the following functions. For the programming the **USB adapter cable incl. software (option)** is necessary. The factory default setting for the LED is self diagnostic.

LED Alarm	LED lights up if the object temperature exceeds or deceeds an alarm threshold
Automatic aiming support	Sighting feature for an accurate aiming of the CS to hot or cold objects
Self diagnostic	LED is indicating different states of the sensor
Temperature Code indication	Indication of the object temperature via the LED
Off	LED deactivated

Automatic Aiming Support

The automatic aiming support helps to adjust the unit to an object which has a temperature different to the background. If this function is activated via software the sensor is looking for the highest object temperature; means the threshold value for activating the LED will be automatically tuned.

This works also if the sensor is aimed at a new object (with probably colder temperature). After expiration of a certain reset time (default setting: 10s) the sensor will adjust the threshold level for activation of the LED new.

Self Diagnostic

With this function the current status of the sensor will be indicated by different flash modes of the LED.

If activated, the LED will show one out of five possible states of the sensor:

Status	LED mode	
Normal	intermittent off	- - - -
Sensor overheated	fast flash	-----
Out of measuring range	double flash	-- -- -- -- --
Not stable	intermittent on	====
Alarm fault	always on	=====

At a supply voltage (Vcc) ≥ 12 V it takes about 5 minutes until the sensor works in a stable mode. Therefore, after switching on the unit, the LED will show a not stable state for up to 5 minutes.

- Sensor overheated: The internal temperature probes have detected an invalid high internal temperature of the CSmicro.
- Out of measuring range: The object temperature is out of measuring range.
- Not stable: The internal temperature probes have detected an unequally internal temperature of the CSmicro.
- Alarm fault: Current through the switching transistor of the open-collector output is too high.

Temperature Code Indication

With this function the current measured object temperature will be indicated as percentage value by long and short flashing of the LED.

At a range setting of 0-100 °C → 0-100% the LED flashing indicates the temperature in °C.

Long flashing → first digit:	xx
Short flashing → second digit:	xx
10-times long flashing → first digit=0:	0x
10-times short flashing → second digit=0:	x0

Examples

87 °C	8-times long flashing indicates	87
and afterwards	7-times short flashing indicates	87
31 °C	3-times long flashing indicates	31
and afterwards	1-time short flashing indicates	31
8 °C	10-times long flashing indicates	08
and afterwards	8-times short flashing indicates	08
20 °C	2-times long flashing indicates	20
and afterwards	10-times short flashing indicates	20

Mechanical Installation

The CSmicro is equipped with a metric M12x1 thread and can be installed either directly via the sensor thread or with the help of the hex nut (standard) to the mounting bracket available. The CSmicro 2WhsLT will be delivered with the massive housing and can be installed via the M18x1-thread.

The sensors CSmicro are sensitive optical systems. Please use only the thread for mechanical installation. Avoid mechanical violence on the head – this may destroy the system (expiry of warranty).

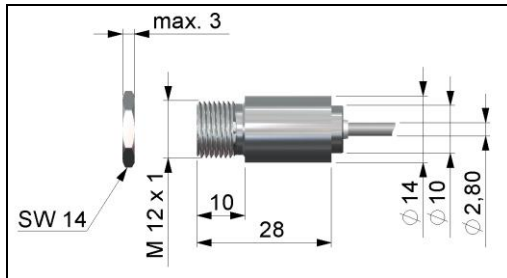

Sensing head [LT/ 3M/ 2WLT/ 2W2M] ¹⁾

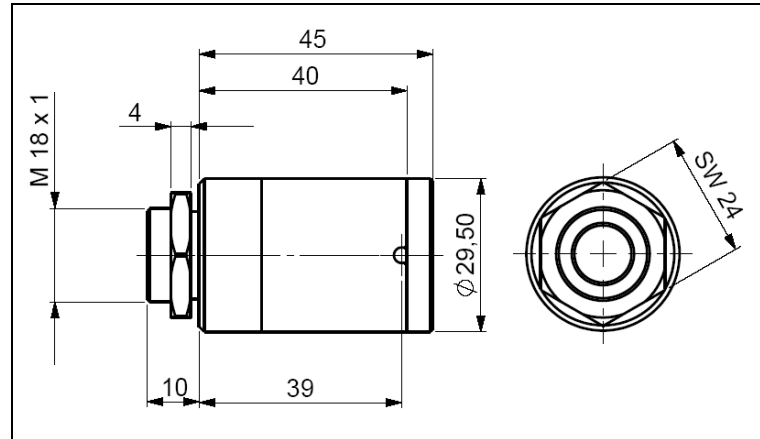

Sensing head [2WhsLT]

¹⁾ On the LTxxCF and 3MxxCF1 models the total length of the sensing head is 32 mm instead of 28 mm.

Mounting Accessories [LT/ 3M/ 2WLT/ 2W2M]

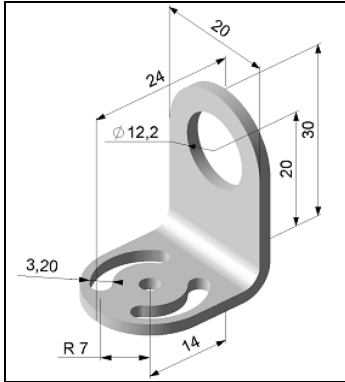

Mounting bracket, adjustable in one axis [ACCTFB]

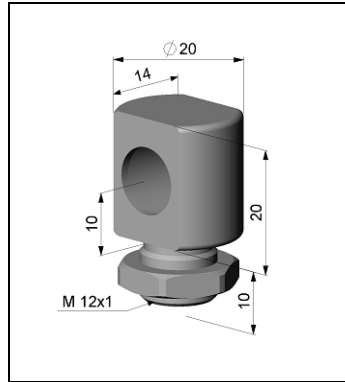

Mounting bolt with M12x1 thread, adjustable in one axis [ACCTMB]

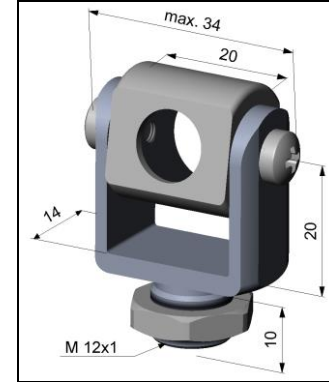

Mounting fork with M12x1 thread, adjustable in 2 axes [ACCTMG]



Mounting bracket, adjustable in two axes [ACCTAB]

The **Mounting fork** can be combined with the **Mounting bracket [ACCTFB]** using the M12x1 thread.

Mounting Accessories [2WhsLT]

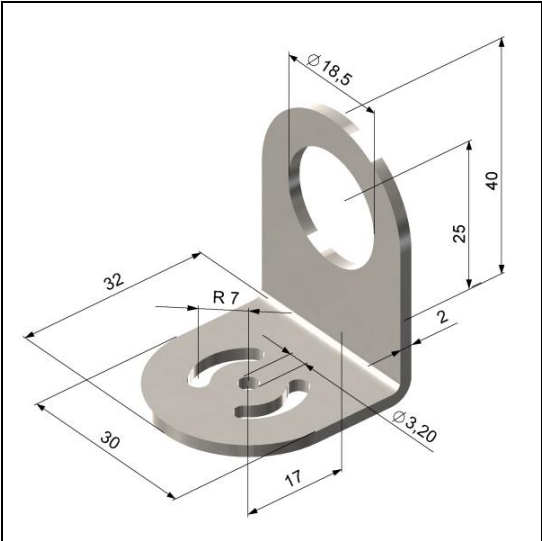

Mounting bracket, adjustable in one axis for 2WhsLT [ACCTFBMH]

Air Purge Collars [LT/ 3M/ 2WLT/ 2W2M]

The lens must be kept clean at all times from dust, smoke, fumes and other contaminants in order to avoid reading errors. These effects can be reduced by using an air purge collar. Make sure to use oil-free, technically clean air, only.

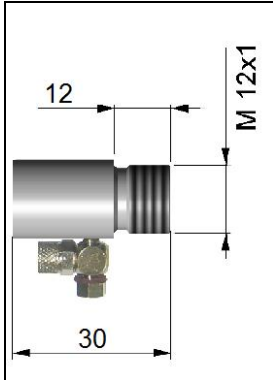

Standard air purge collar;
fits to the mounting bracket;
hose connection: 3x5 mm
[ACCSAP]/ for heads with a
D:S ratio $\geq 10:1$

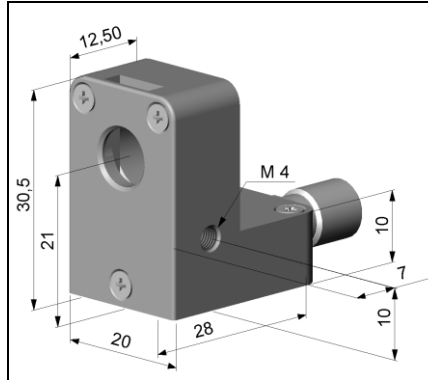

**Laminar air purge collar – the sideward
air outlet prevents a cooling down of the object
in short distances; hose connection: 3x5 mm
[ACCTAPL]**



A combination of the
Laminar air purge collar
with the bottom section of
the **Mounting fork** allows
an adjustment in two axes.
[ACCTAPL+ACCTMG]

The needed amount of air (approx. 2...10 l/ min.) depends on the application and the installation conditions on-site.

Air Purge Collar [2WhsLT]

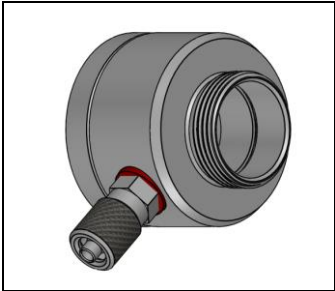
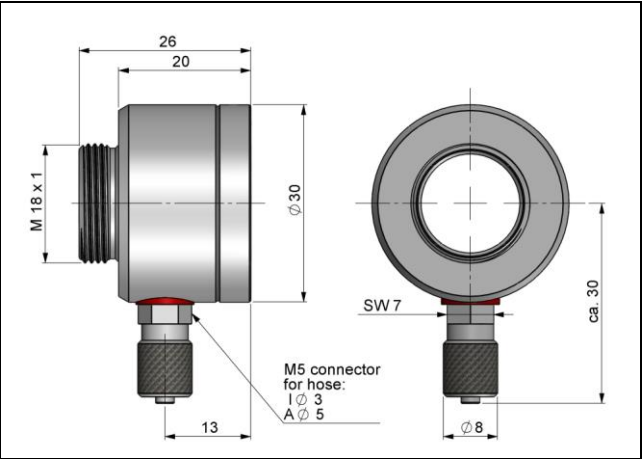

Air purge collar for 2WhsLT head [ACCTAPMH]

Further Accessories

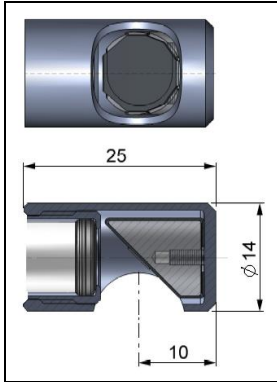

Right angle mirror
Enables measurement
with 90° angle
[ACCTRAM]

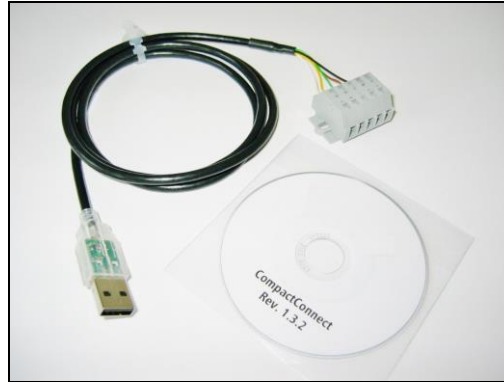

USB-Kit: USB programming adaptor
incl. terminal block and software CD
[ACCSUSBK]

Tilt Assembly

With this mounting accessory a fine adjustment of the CS with an off-axis angle +/- 6,5° is possible.

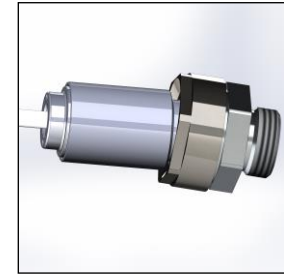
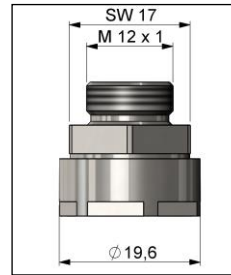

Tilt assembly [ACCTTAS]

- ▶ All accessories can be ordered using the according part numbers in brackets [].

Electrical Installation

Analog Mode

CSmicro LT/ 3M as analog device (mV output on OUT pin)

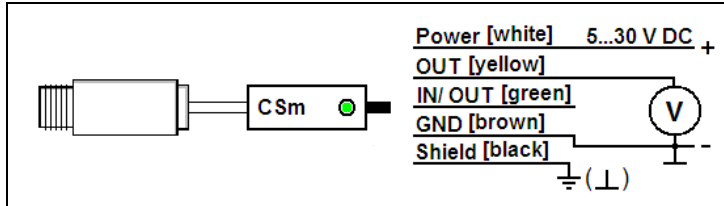

The output impedance must be $\geq 10\text{k}\Omega$.

IMPORTANT:

The shield [black] on the CSmicro (exception: CSM 2WLTxxH) is not connected to GND [brown]. It is necessary to connect the shield to ground or GND (whichever works best)!

Use a separate, stabilized power supply with an output voltage in the range **5-30 V DC**. The residual ripple of the power supply should be max. **200 mV**. For all power and data lines use shielded cables only.

CSmicro 2W as analog device (mA two-wire-output)

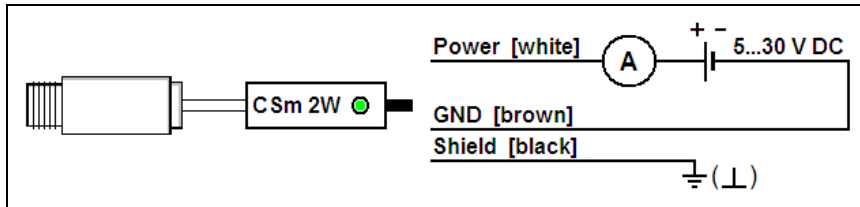

The maximum loop impedance is $1000\ \Omega$.

CSmicro 2W LTxxH as analog device (mA two-wire-output) – current measurement in GND- (Loop-) line

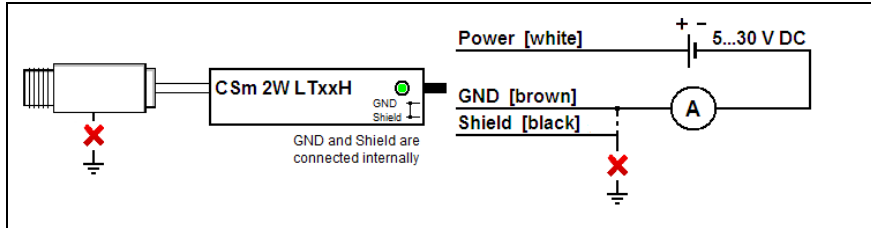

On the models LT15H and LT22H (sensing heads for ambient temperatures up to 180 °C) and on the special versions for 250 °C ambient temperature the GND and Shield is connected inside the electronics.

Special note for current measurement in GND- (Loop-) line:

In this case the sensing head must be installed isolated from ground. A connection of the GND or Shield wire to earth is also not allowed.

For a current measurement in the Power- (Loop+) line the drawing **CSmicro 2W as analog device** is valid. The Shield should be connected to ground or GND.

The maximum loop impedance is 1000 Ω .

Maximum Loop Impedance [2W models]

The maximum impedance of the current loop depends on the supply voltage level:

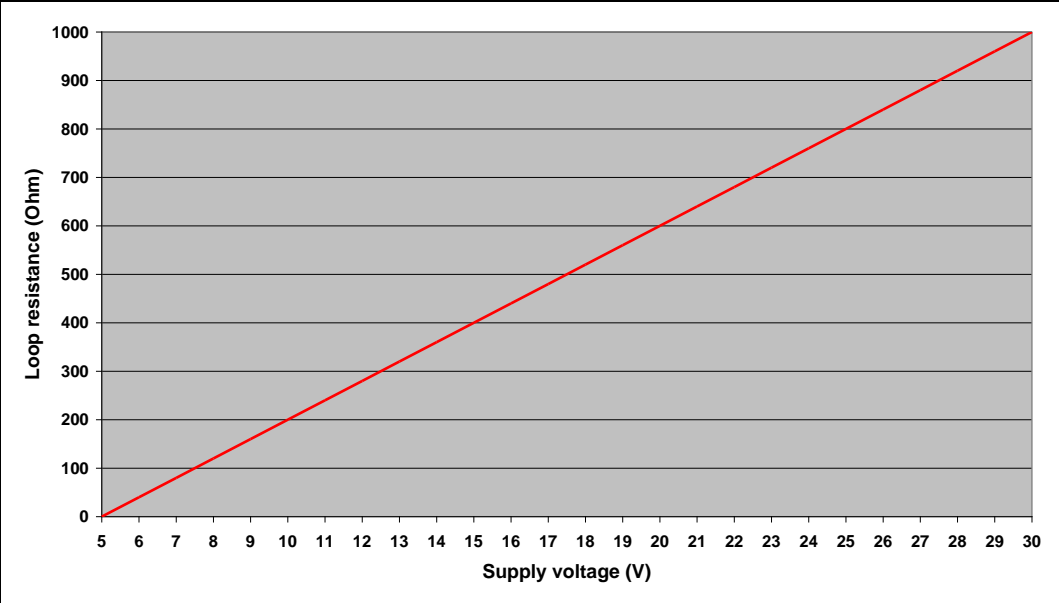

Digital Mode

For a digital communication the optional USB programming kit is required. Please connect each wire of the USB adapter cable with the same coloured wire of the sensor cable by using the terminal block. Press with a screw driver as shown in the picture to loose a contact.

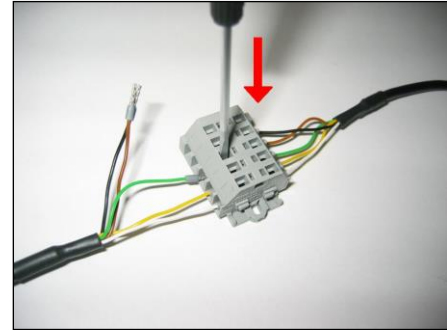

The sensor is offering two ways of digital communication:

- bidirectional communication (sending and receiving data)
- unidirectional communication (burst mode – the sensor is sending data only)

Digital mode [LT/ 3M]

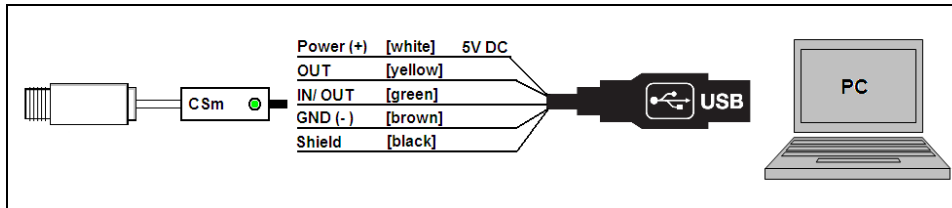

Analog + Digital mode combined [2W]

The two-wire models are able to work in the digital mode and simultaneously as analog device (4-20 mA). In this case the sensor will be powered by the USB interface (5 V).

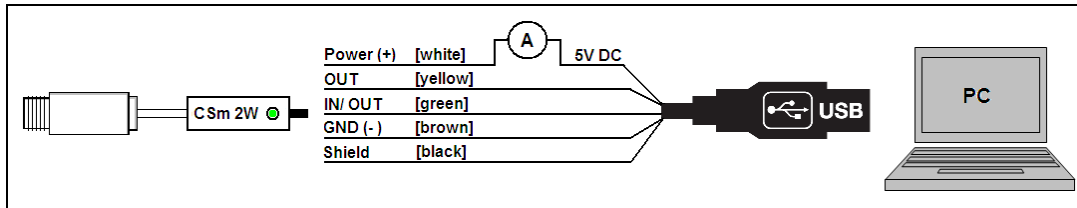

Direct connection to an RS232 interface on the computer

For a bidirectional RS232 connection of the sensor the following interface circuit can be used: MAX3381E (manufacturer: Maxim) ► **Appendix D:**

Model	CSv1/ CSMv1	CSv2	CSMv2	CSM2W/ CX
UART voltage (Rx D)	5 V	3,3 V	3,3 V	3,3 V
UART voltage (Tx D)	5 V	2,5 V	2,5 V	2,5 V

previous sensor versions:

CSv1 CS/ version 1 (→ 12/2010)

CSMv1 CSmicro/ version 1 (→ 09/2011)

Alarm Output

Open collector output [LT/ 3M]

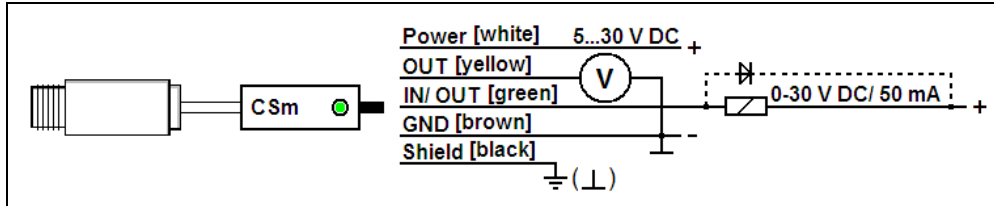

The open collector output is an additional alarm output on the CSmicro and can control an external relay e.g. In addition the analog output can be used simultaneously.

Open collector output [2W]

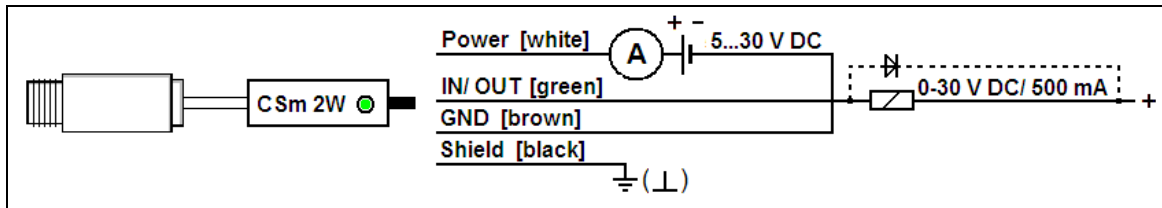

Software CompactConnect

Installation

Insert the installation CD into the according drive on your computer. If the autorun option is activated the installation wizard will start automatically.

Otherwise please start **CDsetup.exe** from the CD-ROM. Follow the instructions of the wizard until the installation is finished.

The installation wizard will place a launch icon on the desktop and in the start menu:

[Start]\Programs\CompactConnect.

If you want to uninstall the software from your system please use the **uninstall icon** in the start menu.

Minimum system requirements:

- Windows XP, Vista, 7, 8
- USB interface
- Hard disc with at least 30 MByte free space
- At least 128 MByte RAM
- CD-ROM drive

You will find a detailed software manual on the CD.

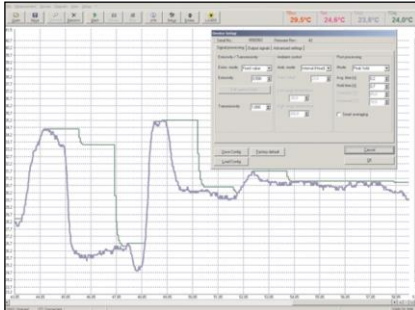

Main Features:

- Graphic display for temperature trends and automatic data logging for analysis and documentation
- Complete sensor setup and remote controlling
- Adjustment of signal processing functions
- Programming of outputs and functional inputs

Communication Settings

Serial Interface

Baud rate: 9600 baud
Data bits: 8
Parity: none
Stop bits: 1
Flow control: off

Protocol

All sensors of the CSmicro series are using a binary protocol. To get a fast communication the protocol has no additional overhead with CR, LR or ACK bytes.
To power the sensor the control signal „DTR“ has to be set.

Digital Command Set

Commands CS/ CSmicro/ CX							
Decimal	HEX	Binary/ ASCII	Command	Data	Answer	Result	Unit
1	0x01	binary	READ Temp - Target	no	byte1 byte2	$= (\text{byte1} \times 256 + \text{byte2} - 1000) / 10$	°C
2	0x02	binary	READ Temp - Head	no	byte1 byte2	$= (\text{byte1} \times 256 + \text{byte2} - 1000) / 10$	°C
3	0x03	binary	READ current Temp - Target	no	byte1 byte2	$= (\text{byte1} \times 256 + \text{byte2} - 1000) / 10$	°C
4	0x04	binary	READ Emissivity	no	byte1 byte2	$= (\text{byte1} \times 256 + \text{byte2}) / 1000$	
5	0x05	binary	READ Transmission	no	byte1 byte2	$= (\text{byte1} \times 256 + \text{byte2}) / 1000$	
9	0x09	binary	READ Processor Temperature	no	byte1	$= (\text{byte1} \times 256 + \text{byte2} - 1000) / 10$	
14	0x0E	binary	READ Serial number	no	byte1 byte2 byte3	$= \text{byte1} \times 65536 + \text{byte2} \times 256 + \text{byte3}$	
15	0x0F	binary	READ FW Rev.	no	byte1 byte2	$= \text{byte1} \times 256 + \text{byte2}$	
129	0x81	binary	SET DAC mV/ mA	byte1	byte1	$\text{byte 1} = \text{mV (mA)} \times 10$ (e.g. 4mA = 4 x 10=40)	°C
130	0x82	binary	RESET of DAC mV/ mA output				
132	0x84	binary	SET Emissivity	byte1 byte2	byte1 byte2	$= (\text{byte1} \times 256 + \text{byte2}) / 1000$	

Temperature calculation at CSmicro hs: $(\text{byte1} \times 256 + \text{byte2} - 10000) / 100$

EXAMPLES (all bytes in HEX)

Readout of object temperature

Send: 01 Command for readout of object temperature
 Receive: 04 D3 Object temperature in tenth degree + 1000
 04 D3 = dec. 1235
 1235 - 1000 = 235
 235 / 10 = **23,5 °C**

Readout of object temperature (at CSmicro 2Whs)

Send: 01 Command for readout of object temperature
 Receive: 30 3E Object temperature in hundredth degree + 10000
 30 3E = dec. 12350
 12350 - 10000 = 2350
 2350 / 100 = 23.50 °C

Set of emissivity

Send: 84 03 B6
 Receive: 03 B6
 03B6 = dec. 950
 950 / 1000 = **0,950**

Burstmode (unidirectional)

After switch on a continuous serial signal will be created. The burst string can be configured with the software.

Burst string	Example	Complete burst string	Conversion to decimal value
2 synchronisation bytes: AAAA	-----		-----
2 bytes for each output value (HI LO)	03B8	AAAA 03B8	process temp [°C] = (Hex \Rightarrow Dec(03B8)-1000)/10 = -4,8

Basics of Infrared Thermometry

Depending on the temperature each object emits a certain amount of infrared radiation. A change in the temperature of the object is accompanied by a change in the intensity of the radiation. For the measurement of “thermal radiation” infrared thermometry uses a wave-length ranging between 1 μ and 20 μ m.

The intensity of the emitted radiation depends on the material. This material contingent constant is described with the help of the emissivity which is a known value for most materials (see enclosed table emissivity).

Infrared thermometers are optoelectronic sensors. They calculate the surface temperature on the basis of the emitted infrared radiation from an object. The most important feature of infrared thermometers is that they enable the user to measure objects contactless. Consequently, these products help to measure the temperature of inaccessible or moving objects without difficulties. Infrared thermometers basically consist of the following components:

- lens
- spectral filter
- detector
- electronics (amplifier/ linearization/ signal processing)

The specifications of the lens decisively determine the optical path of the infrared thermometer, which is characterized by the ratio Distance to Spot size.

The spectral filter selects the wavelength range, which is relevant for the temperature measurement. The detector in cooperation with the processing electronics transforms the emitted infrared radiation into electrical signals.

Emissivity

Definition

The intensity of infrared radiation, which is emitted by each body, depends on the temperature as well as on the radiation features of the surface material of the measuring object. The emissivity (ϵ – Epsilon) is used as a material constant factor to describe the ability of the body to emit infrared energy. It can range between 0 and 100 %. A “blackbody” is the ideal radiation source with an emissivity of 1,0 whereas a mirror shows an emissivity of 0,1.

If the emissivity chosen is too high, the infrared thermometer may display a temperature value which is much lower than the real temperature – assuming the measuring object is warmer than its surroundings. A low emissivity (reflective surfaces) carries the risk of inaccurate measuring results by interfering infrared radiation emitted by background objects (flames, heating systems, chamottes). To minimize measuring errors in such cases, the handling should be performed very carefully and the unit should be protected against reflecting radiation sources.

Determination of unknown Emissivities

- ▶ First, determine the actual temperature of the measuring object with a thermocouple or contact sensor. Second, measure the temperature with the infrared thermometer and modify the emissivity until the displayed result corresponds to the actual temperature.
- ▶ If you monitor temperatures of up to 380°C you may place a special plastic sticker (emissivity dots – part number: ACLSED) onto the measuring object, which covers it completely. Now set the emissivity to 0,95 and take the temperature of the sticker. Afterwards, determine the temperature of the adjacent area on the measuring object and adjust the emissivity according to the value of the temperature of the sticker.

-
- Cove a part of the surface of the measuring object with a black, flat paint with an emissivity of 0,98. Adjust the emissivity of your infrared thermometer to 0,98 and take the temperature of the colored surface. Afterwards, determine the temperature of a directly adjacent area and modify the emissivity until the measured value corresponds to the temperature of the colored surface.

CAUTION: On all three methods the object temperature must be different from ambient temperature.

Characteristic Emissivities

In case none of the methods mentioned above help to determine the emissivity you may use the emissivity tables ► **Appendix A and B**. These are average values, only. The actual emissivity of a material depends on the following factors:

- temperature
- measuring angle
- geometry of the surface
- thickness of the material
- constitution of the surface (polished, oxidized, rough, sandblast)
- spectral range of the measurement
- transmissivity (e.g. with thin films)

Appendix A – Emissivity Table Metals

Material		typical Emissivity			
		1,0 μm	1,6 μm	5,1 μm	8-14 μm
Aluminium	non oxidized	0,1-0,2	0,02-0,2	0,02-0,2	0,02-0,1
	polished	0,1-0,2	0,02-0,1	0,02-0,1	0,02-0,1
	roughened	0,2-0,8	0,2-0,6	0,1-0,4	0,1-0,3
	oxidized	0,4	0,4	0,2-0,4	0,2-0,4
Brass	polished	0,35	0,01-0,05	0,01-0,05	0,01-0,05
	roughened	0,65	0,4	0,3	0,3
	oxidized	0,6	0,6	0,5	0,5
Copper	polished	0,05	0,03	0,03	0,03
	roughened	0,05-0,2	0,05-0,2	0,05-0,15	0,05-0,1
	oxidized	0,2-0,8	0,2-0,9	0,5-0,8	0,4-0,8
Chrome		0,4	0,4	0,03-0,3	0,02-0,2
Gold		0,3	0,01-0,1	0,01-0,1	0,01-0,1
Haynes	alloy	0,5-0,9	0,6-0,9	0,3-0,8	0,3-0,8
Inconel	electro polished	0,2-0,5	0,25	0,15	0,15
	sandblast	0,3-0,4	0,3-0,6	0,3-0,6	0,3-0,6
	oxidized	0,4-0,9	0,6-0,9	0,6-0,9	0,7-0,95
Iron	non oxidized	0,35	0,1-0,3	0,05-0,25	0,05-0,2
	rusted		0,6-0,9	0,5-0,8	0,5-0,7
	oxidized	0,7-0,9	0,5-0,9	0,6-0,9	0,5-0,9
	forged, blunt	0,9	0,9	0,9	0,9
	molten	0,35	0,4-0,6		
Iron, casted	non oxidized	0,35	0,3	0,25	0,2
	oxidized	0,9	0,7-0,9	0,65-0,95	0,6-0,95

Material		typical Emissivity			
		1,0 μm	1,6 μm	5,1 μm	8-14 μm
Spectral response					
Lead	polished	0,35	0,05-0,2	0,05-0,2	0,05-0,1
	roughened	0,65	0,6	0,4	0,4
	oxidized		0,3-0,7	0,2-0,7	0,2-0,6
Magnesium		0,3-0,8	0,05-0,3	0,03-0,15	0,02-0,1
Mercury			0,05-0,15	0,05-0,15	0,05-0,15
Molybdenum	non oxidized	0,25-0,35	0,1-0,3	0,1-0,15	0,1
	oxidized	0,5-0,9	0,4-0,9	0,3-0,7	0,2-0,6
Monel (Ni-Cu)		0,3	0,2-0,6	0,1-0,5	0,1-0,14
Nickel	electrolytic	0,2-0,4	0,1-0,3	0,1-0,15	0,05-0,15
	oxidized	0,8-0,9	0,4-0,7	0,3-0,6	0,2-0,5
Platinum	black		0,95	0,9	0,9
Silver		0,04	0,02	0,02	0,02
Steel	polished plate	0,35	0,25	0,1	0,1
	rustless	0,35	0,2-0,9	0,15-0,8	0,1-0,8
	heavy plate			0,5-0,7	0,4-0,6
	cold-rolled	0,8-0,9	0,8-0,9	0,8-0,9	0,7-0,9
	oxidized	0,8-0,9	0,8-0,9	0,7-0,9	0,7-0,9
Tin	non oxidized	0,25	0,1-0,3	0,05	0,05
Titanium	polished	0,5-0,75	0,3-0,5	0,1-0,3	0,05-0,2
	oxidized		0,6-0,8	0,5-0,7	0,5-0,6
Wolfram	polished	0,35-0,4	0,1-0,3	0,05-0,25	0,03-0,1
Zinc	polished	0,5	0,05	0,03	0,02
	oxidized	0,6	0,15	0,1	0,1

Appendix B – Emissivity Table Non Metals

Material		typical Emissivity			
		1,0 μm	2,2 μm	5,1 μm	8-14 μm
Spectral response					
Asbestos		0,9	0,8	0,9	0,95
Asphalt				0,95	0,95
Basalt				0,7	0,7
Carbon	non oxidized		0,8-0,9	0,8-0,9	0,8-0,9
	graphite		0,8-0,9	0,7-0,9	0,7-0,8
Carborundum			0,95	0,9	0,9
Ceramic		0,4	0,8-0,95	0,8-0,95	0,95
Concrete		0,65	0,9	0,9	0,95
Glass	plate		0,2	0,98	0,85
	melt		0,4-0,9	0,9	
Grit				0,95	0,95
Gypsum				0,4-0,97	0,8-0,95
Ice					0,98
Limestone				0,4-0,98	0,98
Paint	non alkaline				0,9-0,95
Paper	any color			0,95	0,95
Plastic >50 μm	non transparent			0,95	0,95
Rubber				0,9	0,95
Sand				0,9	0,9
Snow					0,9
Soil					0,9-0,98
Textiles				0,95	0,95
Water					0,93
Wood	natural			0,9-0,95	0,9-0,95

Appendix C – Smart Averaging

The average function is generally used to smoothen the output signal. With the adjustable parameter time this function can be optimal adjusted to the respective application. One disadvantage of the average function is that fast temperature peaks which are caused by dynamic events are subjected to the same averaging time. Therefore those peaks can only be seen with a delay on the signal output.

The function **Smart Averaging** eliminates this disadvantage by passing those fast events without averaging directly through to the signal output.

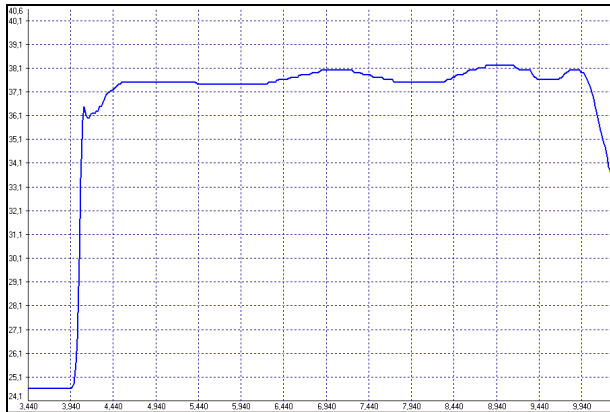

Signal graph with Smart Averaging function

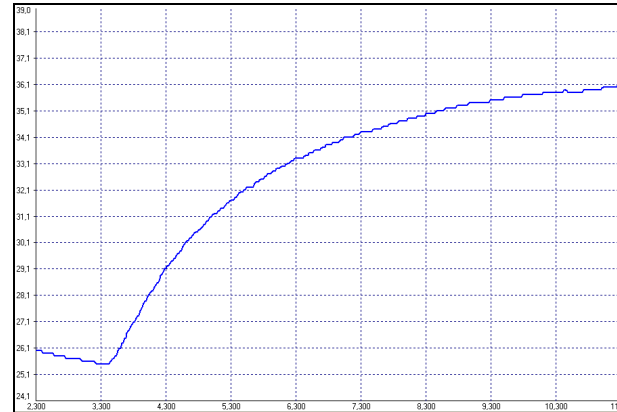

Signal graph without Smart Averaging function

Appendix D – Direct Connection to an RS232 Interface

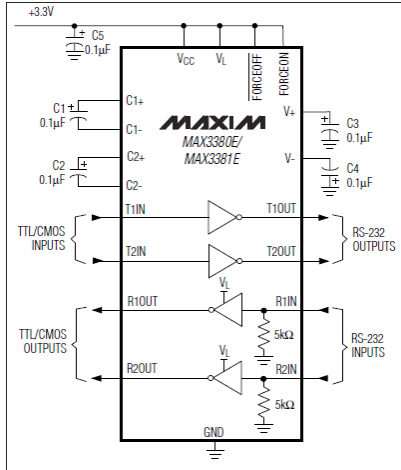

CSM connections:

TxD (yellow) to T1IN
 RxD (green) to R1OUT
 GND (brown) to GND

PC connections:

connect T1OUT with RxD (PC)
 connect R1IN with TxD (PC)

Appendix E – Declarations of Conformity

EG-Konformitätserklärung EU Declaration of Conformity



Wir / We

Optris GmbH
Fendinand Buisson Str. 14
D-13127 Berlin

erklären in alleiniger Verantwortung, dass
declare on our own responsibility that

die Produktserie optris CSmicro
the product group optris CSmicro

den Anforderungen der EMV-Richtlinie 2014/30/EU und der Niederspannungsrichtlinie 2014/35/EU
entspricht.
meets the provisions of the EMC Directive 2014/30/EU and the Low Voltage Directive 2014/35/EU.

Angewandte harmonisierte Normen:
Applied harmonized standards:

EMV Anforderungen / EMC General Requirements:
EN 61326-1:2013 (Grundlegende Prüfanforderungen / Basic requirements)
EN 61326-2-3:2013

Gerätesicherheit von Messgeräten / Safety of measurement devices:

EN 61010-1:2010
EN 60825-1:2015 (Lasersicherheit / Laser safety)

Dieses Produkt erfüllt die Vorschriften der Richtlinie 2011/65/EU (RoHS) des Europäischen
Parlaments und des Rates vom 8. Juni 2011 zur Beschränkung der Verwendung bestimmter
gefährlicher Stoffe in Elektro- und Elektronikgeräten.
This product is in conformity with Directive 2011/65/EU (RoHS) of the European Parliament and of
the Council of 8 June 2011 on the restriction of the use of certain hazardous substances in
electrical and electronic equipment.

Berlin, 04.11.2015

Ort, Datum / place, date

Dr. Ulrich Kienitz
Geschäftsführer / General Manager

EG-Konformitätserklärung EU Declaration of Conformity



Wir / We

Optris GmbH
Ferdinand Buisson Str. 14
D-13127 Berlin

erklären in alleiniger Verantwortung, dass
declare on our own responsibility that

die Produktserie optris CSmicro 2W/ CSmicro hs
the product group optris CSmicro 2W/ CSmicro hs

den Anforderungen der EMV-Richtlinie 2014/30/EU und der Niederspannungsrichtlinie 2014/35/EU
entspricht.
meets the provisions of the EMC Directive 2014/30/EU and the Low Voltage Directive 2014/35/EU.

Angewandte harmonisierte Normen:
Applied harmonized standards:

EMV Anforderungen / EMC General Requirements:

EN 61326-1:2013 (Grundlegende Prüfanforderungen / Basic requirements)
EN 61326-2-3:2013

Gerätesicherheit von Messgeräten / Safety of measurement devices:

EN 61010-1:2010
EN 60825-1:2015 (Lasersicherheit / Laser safety)

Dieses Produkt erfüllt die Vorschriften der Richtlinie 2011/65/EU (RoHS) des Europäischen Parlaments und des Rates vom 8. Juni 2011 zur Beschränkung der Verwendung bestimmter gefährlicher Stoffe in Elektro- und Elektronikgeräten.
This product is in conformity with Directive 2011/65/EU (RoHS) of the European Parliament and of the Council of 8 June 2011 on the restriction of the use of certain hazardous substances in electrical and electronic equipment.

Berlin, 04.11.2015

Ort, Datum / place, date

A handwritten signature in black ink, appearing to read "U. Kientz".

Dr. Ulrich Kientz
Geschäftsführer / General Manager