

ME30

Blackbody Calibration Source

for Calibration of Radiation Thermometers and Thermal Imaging Systems
Temperature Range from -20 °C to 350 °C ¹

HEITRONICS
Infrarot Messtechnik



- Aperture: Ø 60 mm (2.36")
- Cavity length: 300 mm (11.8")
- Uncertainty: 0.15 °C ... 0.70 °C
- Portable, weight: approx. 20 kg (44 lb)
- Cavity source immersed in a liquid bath
- Liquid volume: 1.35 litres (0.4 gal)
- Excellent temperature uniformity
- Precision controller, including a programmer
- High stability, low controller oscillations
- Fast heat-up: approx. 1 h for stabilization
- Nitrogen rinsing to suppress dew point
- Traceable by RTD-Pt100 (DAkkS calibrated) or
- Traceable by HEITRONICS Transfer Radiation Thermometer (TRT)
- Calibration of 3 mm RTD's and thermocouples
- Built-in cooling coil for an external cooler

According to the latest development in technology a Blackbody Calibration Source has to be used to calibrate infrared radiation thermometers and thermal imaging systems with temperature ranges within -20 °C to 350 °C.

An ideal blackbody sends out radiation - in a defined wavelength region - which only depends on its temperature. Its emissivity is 1 (Planck's law of radiation). A surface which comes very close to this perfect radiator is achieved by the aperture of a cavity whose inner surface is blackened and at a uniform temperature. When the opening is small with regard to the dimensions of the cavity,

blackbody behavior is approximated. The emissivity is towards 1. This condition is achieved by a cylinder (tube with a bottom) when the ratio length to diameter is high. Therefore the opening of the cylinder is excellently suited as a calibration source for infrared radiation thermometers and thermal imaging systems.

Calibration

For calibration, the radiation thermometer, respectively the thermal imaging system, is placed at a certain distance in front of the blackbody's aperture and

the output signal is compared to the radiation temperature T_{rad} of the blackbody. Its radiation temperature T_{rad} can be measured by a precise HEITRONICS Transfer Radiation Thermometer (TRT) which must have the same spectral response as the radiation thermometer to be tested. Also it can be calculated by an external precise resistance thermometer RTD-Pt100 and a precise meter.

History

In consideration of the increasingly demanding requirements for a reliable and accurate calibration source for the

¹ -20 to 40 °C with chiller

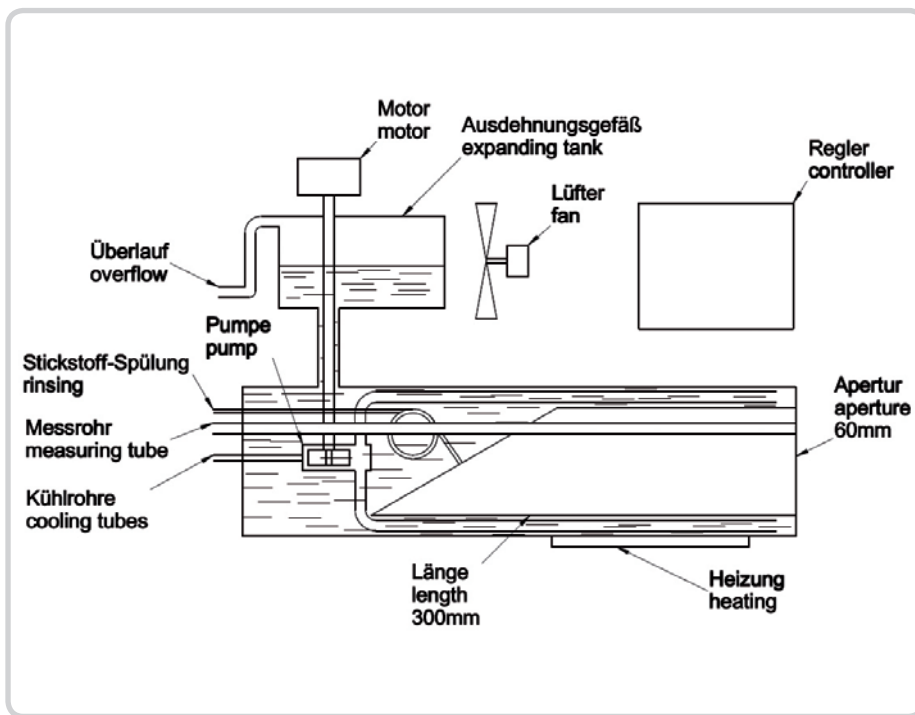

Figure 1: ME30 Blackbody Calibration Source (schematic presentation)

Blackbody Radiation Source ME30

The ME30 covers the whole temperature range from -20 °C to 350 °C with only two different bath liquids: a special silicone oil for temperatures from 90 °C to 350 °C and another one for temperatures from -20 °C to 180 °C . Below 40 °C an external chiller is required.

In a schematic draft (Figure 1) the blackbody ME30 is illustrated. The cavity consists of a brass tube, with a diameter and clear aperture of 60 mm. The total length measures 300 mm. The back end is sealed by a 30° backplane. The inner surface is coated with a heat resistant black varnish. The outer tube measures 90 mm in diameter with a total length of 400 mm. The space between the tubes accommodates the bath liquid. The total volume is 1.35 litres. A powerful pump is placed behind the cavity. Six pump tubes around the circumference of the inner cavity allow for rapid circulation of the bath liquid. As a result the cavity is kept at an evenly distributed temperature. The circulation is completed within a few seconds. With this construction, excellent temperature uniformity is achieved.

rapidly expanding radiometric, scientific and industrial market in low temperature measurements, the Mester engineering office developed the ME20 Blackbody Calibration Source. This happened 1998. The design was supported by the German VDI/VDE Committee 2.51 "Applied Radiation Thermometry" and by the "Working group 7.32 Infrared Radiation Thermometry" of the German National Institute of Natural and Engineering Sciences (Physikalisch Technische Bundesanstalt PTB). The blackbody ME20 meets all requirements for adjusting and calibration of radiation thermometers according to VDI/VDE-guideline 3511, Temperature measurement in industry, Part 4 Radiation thermometry and Part 4.4 Calibration of radiation thermometers.

A high emissivity $\epsilon = 0.9994$ was achieved by using a cylinder of brass with a length of 300 mm and an aperture of

60 mm. This cylinder is immersed in a liquid bath. The fluid is rolled over strongly by a pump. Therefore the inner surface of the cylinder has very good temperature homogeneity.

During 1999-2009 Blackbody Calibration Sources of the ME20 series were sold to several metrological institutes, to many manufacturers of radiation thermometers and numerous laboratories and companies all over the world.

In 2010 development, manufacturing and sales were taken over by HEITRONICS Infrarot Messtechnik GmbH. The ME20 series was completely redesigned. As a result of this redesign the universal blackbody ME30 was generated, which includes not only all the major data of the series ME20 but also many improvements especially concerning safety operation and easy replacements of wear parts without a need for new adjustment and calibration.

In addition, since the bath volume is very small, an average heat-up time of only 1 hour results. The circulating bath is connected to an expansion tank on top by a thin tube. It has enough space to collect the maximum amount of approx. 30 % of expanding liquid. The fluid in the expansion tank no longer takes part in the circulation. A fan cools the expansion tank, so that even at the highest bath temperature of 350 °C the temperature of the liquid in the expansion tank is $< 150\text{ °C}$. Since the expansion tank is

kept at a relatively low temperature, the hot bath fluid does not directly contact the oxygen in the air.

The determination of the bath temperature T_{probe} is possible at one copper tube with an inner diameter of 6 mm. It is tightly soldered to the outer surface of the inner cavity for optimal thermal contact. This measuring tube provides

Controlling of bath temperature is stable only 15 °C above ambient temperature (approx. 40 °C). Therefore, an external chiller must be used for lower temperatures. A cooling tube is placed within the bath. To suppress building of ice or dew point the cavity can be rinsed by dry nitrogen or clean dry air. The tube is led through the bath and ends at the backplane of the cavity. The nitrogen or

and III. Using blackbody ME30, calibration schemes I and IIa are applied.

Calibration scheme I

Contact thermometers can be used to measure the temperature T_{probe} at a clearly defined place and determine out of it the radiation temperature T_{rad} . For this the temperature difference ΔT_{probe} between the temperature of the contact thermometer T_{probe} , the surface temperature T_{surf} of the cavity and the temperature correction ΔT_{ϵ} caused by the emissivity ϵ_{bb} of the blackbody ME30 in the spectral range of the radiation thermometer have to be known. Then it is possible to calculate from the temperature T_{probe} the radiation temperature T_{rad} dependent on T_{probe} .

$$T_{\text{rad}} = T_{\text{probe}} - \Delta T_{\text{cor}} ; \text{ with } \Delta T_{\text{cor}} = \Delta T_{\text{probe}} + \Delta T_{\epsilon}$$

Due to the high value $\epsilon_{\text{bb}} = 0.9994 \pm 0.0002$ and because the temperature difference ΔT_{probe} is low also the value ΔT_{cor} is low.

Calibration scheme IIa

A high precise thermometer as the HEITRONCS Transfer Radiation Thermometer (TRT) can be used to calibrate a Blackbody Calibration Source like ME30.

For this the deviation ΔT_{cor} of the temperature measurement T_{probe} by an external contact thermometer or the deviation from the actual value of the controller temperature dependent on T_{probe} is determined. Spectral response (effective wavelength λ_{ϵ}) of the radiation thermometer to be calibrated and spectral response of the TRT must coincide.

Detailed information of the calibration schemes you will find in the instruction manual ME30.



Figure 2: Calibration of ME30 with Transfer Radiation Thermometer (TRT)

access for an external temperature probe (RTD Pt100) enabling precise measurement and monitoring of the cavity surface temperature inside the bath. A place near to the backplane is chosen for measuring the temperature T_{probe} with an external RTD Pt100. At an additional tube - also near the back panel - there is built in a Pt100 as a temperature probe for the controller.

the air will take the bath temperature and does not affect the inner surface temperature of the cavity.

Calibration

Several methods for calibrating radiation thermometers you will find in the above mentioned VDI/VDE-guideline. They are called calibration scheme I, IIa, IIb, IIc

ME30 Specifications

Temperature range:	-20 °C to 350 °C external chiller needed for temperature < 40°C	Controller:	Eurotherm 2408; 4 Digit-PID incl. a programmer for 8 temperatures
Emissivity:	0.9994 ± 0.0002	Interface:	RS 232 (opt. 485)
Aperture dimensions:	d = 60 mm	Controller set ability:	0.1 °C
Cavity length:	300 mm	Controller oscillations:	0.03 °C to 0.1 °C
Bath fluid:		Ambient temperature:	15 °C to 35 °C
Sil. oil Korasilon M10:	-20 °C to 180°C	Heat-up time for stabilisation:	approx. 1 h
Sil. oil Wacker AP 200 stab:	90 °C to 350 °C	Storage temperature:	-40 °C to 70 °C
Bath volume:	1.35 litres	Humidity:	10 to 90 % not condens.
Voltage:	230 VAC ± 10%	Heating power:	1000 W
Temperature monitoring:	JUMO eTRON M	Dimensions:	L470 x W210 x D430 mm
IP rating:	IP 20	Admissible altitude:	< 2000 m o. NHN
		Weight:	approx. 20 kg

Temperature non-uniformity ΔT at a cavity depth of 200 ... 300 mm

-20 °C to 100 °C: $\Delta T < 0.1$ °C; 100 °C to 200 °C: $\Delta T < 0.3$ °C; 200 °C to 350 °C: $\Delta T < 0.5$ °C

Temperature non-uniformity ΔT at a cavity depth of 30 ... 300 mm

-20 °C to 100 °C: $\Delta T < 0.1$ °C; 100 °C to 200 °C: $\Delta T < 0.5$ °C; 200 °C to 350 °C: $\Delta T < 0.8$ °C

Standard uncertainty u of the radiation temperature at a cavity depth of 200 mm to 300 mm

Calibration with RTD Pt100 calibrated by a certified laboratory (in Germany: DAkkS)

-20 °C to 100 °C: $u \leq 0.23$ °C; 100 °C to 200 °C: $u \leq 0.36$ °C; 200 °C to 350 °C: $u \leq 0.54$ °C

Standard uncertainty u of the radiation temperature at a cavity depth of 200 mm to 300 mm

Calibration with a HEITRONICS Transfer Radiation Thermometer (TRT)

-20 °C to 100 °C: $u \leq 0.11$ °C; 100 °C to 200 °C: $u \leq 0.16$ °C; 200 °C to 350 °C: $u \leq 0.21$ °C

Uncertainty will increase when areas of the cavity below 200 mm will be measured during calibration.

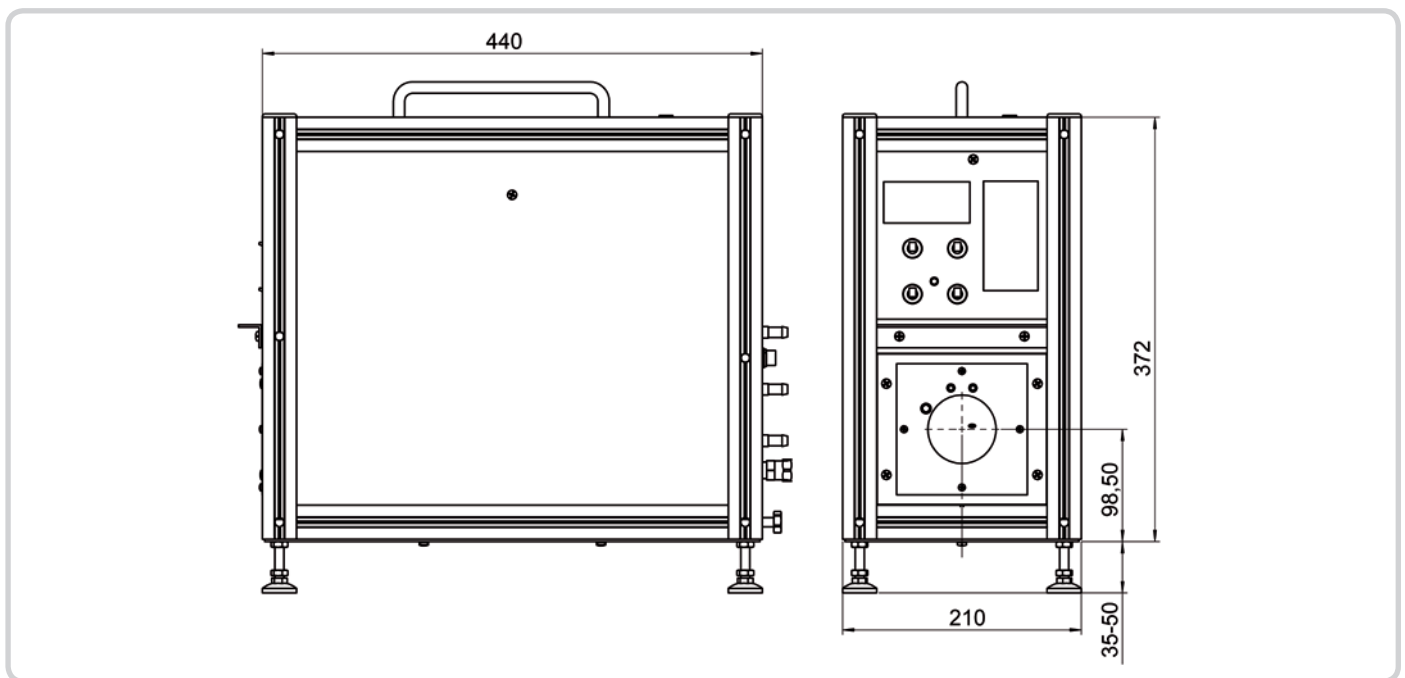

Figure 3: ME30 Dimensions in mm

Further information, interesting facts and downloads around the topic „Non-Contact Temperature Measurement from -100 °C to 3000 °C“ are available on our website.

MTS Messtechnik Schaffhausen GmbH
Mühlenstrasse 4, CH-8260 Stein am Rhein
Telefon +41 52-672 50 00
Telefax +41 52-672 50 01
www.mts.ch, e-mail: info@mts.ch

Messen Prüfen Automatisieren www.mts.ch