

USER MANUAL



JUNIOR JR-D / JR20-D

**DIGITAL INDICATOR
COUNTER - TOTALIZER
TACHOMETER - FREQUENCY METER**

INDEX
GENERAL INFORMATION

Package contents	4
Recycling instructions	4
General safety considerations	4
Symbols identification	4
Maintenance	5
Warranty	5
Conformity declaration	6
Device description	7
Dimensions and mounting	7
Display and keyboard	8
Installing and connecting recommendations	8
Connections	9
Wiring diagram for MAGNETIC sensor / SWITCH CONTACT input signal	9
Wiring diagram for NAMUR sensor input signal	10
Wiring diagram for NPN, PNP and TTL sensors or 24V DC ENCODER	10
High voltage input signal wiring diagram	10
Remote counter RESET function wiring diagram	10
Relays output	11

INPUT CONFIGURATION

Configuration menu	12
Input configuration	12

DISPLAY CONFIGURATION

Display programming	14
Counter mode (#1)	14
Tachometer rpm mode (#2)	15
Tachometer rate mode (#3)	15
Average measurement maximum time (tMAH) and time limit (tLIM) (tachometer mode only)	16

SETPOINTS CONFIGURATION

Setpoints configuration	17
Counter mode ('Cont')	17
Tachometer mode ('tACH' y 'rAtE')	18

AVAILABLE KEYBOARD FUNCTIONS

TOTALIZER, MAX/MIN and RESET functions	19
Counter mode ('Cont')	19
Tachometer mode ('tACH' y 'rAtE')	19
Direct access to Setpoints value	20
Return to default configuration	20
Access to lock-out configuration menu	20

CONFIGURATION LOCK-OUT

Lock-out menu	21
---------------------	----

OUTPUT OPTION

Description	23
Function modes description	23
HI/LO mode activation	23
Time delay (tachometer mode 'tACH' and 'rAtE' only)	23
Asymmetrical hysteresis (tachometer mode 'tACH' and 'rAtE' only)	23
1, 2, 3 and 4 control modes (for counter mode 'Cont' and Setpoint 2 only)	24
Pulse output "PuLS" (for counter mode 'Cont' only)	24
Latched output "LAtC" (for counter mode 'Cont' only)	24

ÍNDICE

Installation 25

SPECIFICATIONS

Technical specifications 26

GENERAL INFORMATION

This manual does not constitute a contract or a commitment on the part of Diseños y Tecnología, S.A. All information contained in this document is subject to change without prior notice.

MANUAL VALID FOR INSTRUMENTS WITH D2.00 SOFT VERSION OR HIGHER

Package contents

With the instrument it is also supplied:

- Quick installation guide.
- Mounting panel accessories (a sealing gasket and 2 fixing clips).
- Wiring accessories (plug-in terminal block connectors and 2 key tools for cable insertion).
- 4 adhesive labels set with engineering units.

Recycling instructions

This electronic instrument is covered by the **2002/96/CE** European Directive so, it is properly marked with the crossed-out wheeled bin symbol that makes reference to the selective collection for electrical and electronic equipment which indicates that at the end of its lifetime, the final user cannot dispose of it as unsorted municipal waste.



In order to protect the environment and in agreement with the European legislation regarding waste of electrical and electronic equipments from products put on the market after 13 August 2005, the user can give it back, without any cost, to the place where it was acquired to proceed to its controlled treatment and recycling.

General safety considerations

All instructions and guidelines for the installation and manipulation that are present in this manual must be considered to ensure personal safety and to prevent damage to either the instrument or any equipment connected to it.

Safety of any equipment incorporated to this instrument is responsibility of the system installer.

If this electronic indicator is used in a manner not specified by the manufacturer in this manual, the protection provided by the instrument may be impaired.

Symbols identification



WARNING: Potential risk of danger.

Read completely related instructions when this symbol appears in order to know the potential risk and to know how to avoid it.



WARNING: Risk of electric shock.



Instrument protected by double isolation or reinforced isolation.

Maintenance

Instrument repairs should only be carried out by the manufacturer or by its authorized partners.

For frontal device cleaning, just wipe it with a damp cloth and neutral soap product. **DO NOT USE SOLVENTS!**

Warranty

All products are warranted against defective material and workmanship for a period of three years from acquisition date.



If a product appears to have a defect or fails during the normal use within warranty period, please contact the distributor from whom you purchased the product to be given proper instructions.

This warranty does not apply to defects resulting from action of the customer such as mishandling or improper interfacing.

The liability under this warranty shall extend only to the repair of the instrument; no responsibility is assumed by the manufacturer for any damage which may result from its use.



All DITEL products benefit from an unlimited and unconditional warranty of three (3) years from the date of their purchase. Now you can extend this period up to five (5) years from the product commissioning, only by fulfilling the corresponding form.

Fill up the form in our website at:
<http://www.ditel.es/warranty>

Conformity declaration

<p>Manufacturer: DITEL - Diseños y Tecnología S.A. Address: Xarol, 8C P.I. Les Guixeres 08915 Badalona. SPAIN</p> <p>Declares, that the product:</p> <p>Name: Digital panel indicator Model: JR-D / JR20-D Specifications: DI 110614</p> <p>Conforms with Directives:</p> <p>EMC 2004/108/CE LVD 2006/95/CE</p> <p>Applicable standards:</p> <p>EN61326-1 EN61010-1</p> <p>Date: 18 December 2012 Signed: Alicia Alarcia Charge: Technical Director</p> 	<p>EN 61326-1 Electrical equipment for measurement, control and laboratory use (EMC)</p> <table border="0"> <tr> <td>EN 61000-4-2</td> <td>Electrostatic discharge (ESD) Air discharge 8kV Contact discharge 4kV</td> <td>Criterion B</td> </tr> <tr> <td>EN 61000-4-3</td> <td>Electromagnetic fields 10 V/m</td> <td>Criterion A</td> </tr> <tr> <td>EN 61000-4-4</td> <td>Fast transients (burst) Power lines 2 kV Signal lines 1 kV</td> <td>Criterion B</td> </tr> <tr> <td>EN 61000-4-5</td> <td>Surge 1 kV L to N 2 kV L,N to Earth 1 kV Signal lines to Earth</td> <td>Criterion B</td> </tr> <tr> <td>EN 61000-4-6</td> <td>RF conducted interference 3 Vrms</td> <td>Criterion A</td> </tr> <tr> <td>EN 61000-4-11</td> <td>Voltage dips: 0% V during 1 cycle 40% V during 10/12 cycles 70% V during 25/30 cycles Short interruptions: 0% V during 250/300 ciclos</td> <td>Criterion B Criterion C Criterion C Criterion C</td> </tr> <tr> <td>CISPR11</td> <td>Emission limits Class B</td> <td></td> </tr> </table> <p>EN 61010-1 Safety requirements for electrical equipment for measurement, control an laboratory use.</p> <p>General safety Overvoltage category II Pollution degree 2 Conductive pollution excluded Isulation type:</p> <table border="0"> <tr> <td>Enclosure:</td> <td>Double</td> </tr> <tr> <td>Power/signal:</td> <td>Basic</td> </tr> <tr> <td>Power/relays:</td> <td>Double</td> </tr> <tr> <td>Signal/relays:</td> <td>Double</td> </tr> </table>	EN 61000-4-2	Electrostatic discharge (ESD) Air discharge 8kV Contact discharge 4kV	Criterion B	EN 61000-4-3	Electromagnetic fields 10 V/m	Criterion A	EN 61000-4-4	Fast transients (burst) Power lines 2 kV Signal lines 1 kV	Criterion B	EN 61000-4-5	Surge 1 kV L to N 2 kV L,N to Earth 1 kV Signal lines to Earth	Criterion B	EN 61000-4-6	RF conducted interference 3 Vrms	Criterion A	EN 61000-4-11	Voltage dips: 0% V during 1 cycle 40% V during 10/12 cycles 70% V during 25/30 cycles Short interruptions: 0% V during 250/300 ciclos	Criterion B Criterion C Criterion C Criterion C	CISPR11	Emission limits Class B		Enclosure:	Double	Power/signal:	Basic	Power/relays:	Double	Signal/relays:	Double
EN 61000-4-2	Electrostatic discharge (ESD) Air discharge 8kV Contact discharge 4kV	Criterion B																												
EN 61000-4-3	Electromagnetic fields 10 V/m	Criterion A																												
EN 61000-4-4	Fast transients (burst) Power lines 2 kV Signal lines 1 kV	Criterion B																												
EN 61000-4-5	Surge 1 kV L to N 2 kV L,N to Earth 1 kV Signal lines to Earth	Criterion B																												
EN 61000-4-6	RF conducted interference 3 Vrms	Criterion A																												
EN 61000-4-11	Voltage dips: 0% V during 1 cycle 40% V during 10/12 cycles 70% V during 25/30 cycles Short interruptions: 0% V during 250/300 ciclos	Criterion B Criterion C Criterion C Criterion C																												
CISPR11	Emission limits Class B																													
Enclosure:	Double																													
Power/signal:	Basic																													
Power/relays:	Double																													
Signal/relays:	Double																													

Device description

All information contained in this manual, unless indicated, is valid for both **JR-D** and **JR20-D** models.

JR-D and **JR20-D** models from KOSMOS serie are digital indicators fully configurables that allow input type selection in order to be used as needed. Available signal inputs are the following:

HIGH VOLTAGE (10 to 600V AC)

SENSORS: **MAGNETIC**, **NAMUR**, **NPN** and **PNP**.

TTL/24V ENCODER

CONTACT SWITCH

The basic instrument consists of a soldered assembly composed of a main board, a display and an input signal circuits. It can also be incorporated, as an option, an extra plug-in 2 SPDT 8A relays circuit output which is isolated from signal input and power supply. This extra circuit has independent connectors that are located on the rear part of the instrument once it is installed.

Both models accept most commonly used pulse generators or transducers to work as an **unidirectional counter** or **tachometer** (rpm or rate). They have configurable factor and offset when are programmed as a counter or easily scalables directly by frontal keys into desired engineering units working as tachometer (rate). They have **4 digits, configurable decimal point and 2 LED's for Setpoints status indication**. They also provide **8V or 24V DC** outputs for sensors excitation.

JR-D model is provided with **14mm-high** digits whereas **JR20-D** has a larger display of **20mm-high** digits that allows a better reading at longer distance. Both have same maximum display range of **0 to 9999** as a counter and tachometer and **0 to 999999** as a totalizer (shown in display separately in two parts of three digits each).

Both devices have three frontal keys to interact with internal software and set configuration in order to adapt their function to particular applications. Device programming runs through some independent menus that show short messages to easily identify input type and/or display configuration steps.

If relays output option card is installed, once it is recognised by the instrument, activates its own configuration menu which is only visible under this conditions.

Dimensions and mounting

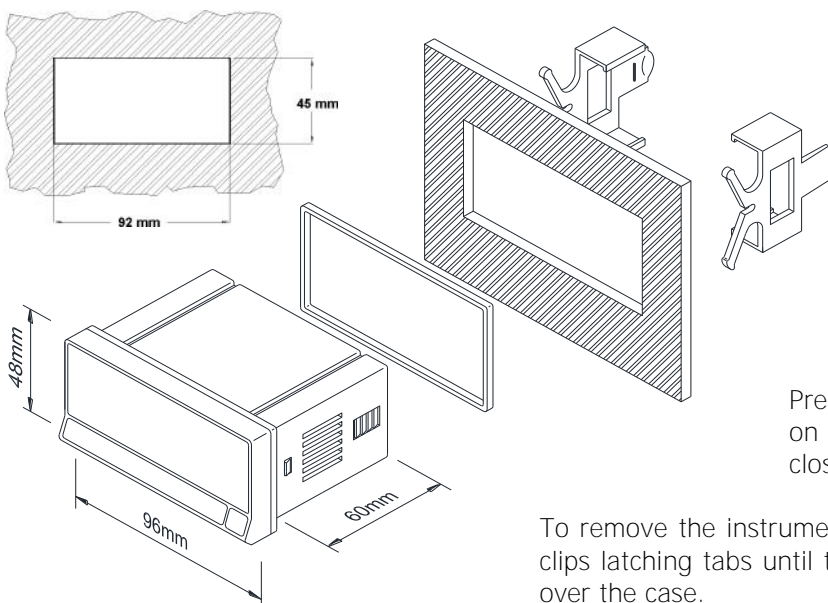

To install the instrument, prepare a 92x45mm panel cut-out and slide the unit inwards making sure of placing the sealing gasket between the front side panel and the frontal bezel.

While holding the unit in place, put the fixing clips on both sides of the case and slide them through the guide tracks until they reach the panel at the rear side.

Press slightly to fasten the clips to the latching slots on the case and get the unit fully assembled and close fitted to achieve a good sealing.

To remove the instrument from the panel, pull outwards the rear fixing clips latching tabs until they are disengaged, then slide fixing clips back over the case.

Display and keyboard

There are two main function modes: **RUN** and **PRO**. **PRO** mode is when configuration menu is entered to program the indicator, whereas **RUN** is the normal mode in which display shows the reading according to configuration and input signal value.

The table below summarizes display parts description and LEDs and keyboard function.

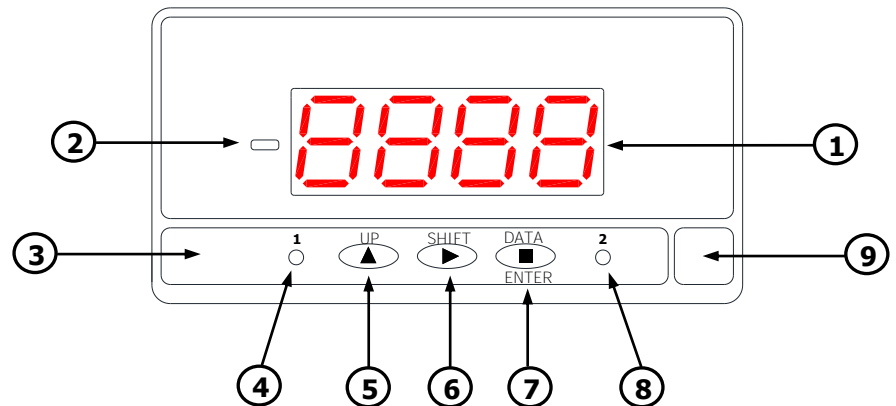

		RUN MODE	PRO MODE
1	4 red digit Display	Shows value according configuration.	Shows steps and data during configuration.
2	Minus sign LED (only in JR-D)	(Not used)	(Not used)
3	Keyboard	—	—
4	Setpoint 1 LED	It illuminates when Setpoint 1 turns active.	It illuminates when Setpoint 1 turns active.
5	UP key	Main Counter RESET (when pressing more than 3s).	Shows Setpoints value. Increases value of active digit.
6	SHIFT key	Displays maximum and minimum stored values (tachometer mode only). After 3s of pressing, sets maximum and/or minimum memorized value to current display value (tachometer mode only). Shows sequentially totalizer value in two parts, 'H' and 'L' of 3 digits each (counter mode only). Totalizer RESET (when pressing more than 3s)	Shifts active digit to the next right digit. Shows sequentially menu options.
7	DATA/ENTER key	Changes to PRO mode.	Validates selected data and parameters. Moves one step forward in configuration menu. Changes to RUN mode.
8	Setpoint 2 LED	It illuminates when Setpoint 2 turns active.	It illuminates when Setpoint 2 turns active.
9	Free space for units label	—	—

Installing and connecting recommendations

This instrument conforms with the following community directives: EMC 2004/108/CE and LVD 2006/95/CE. Refer to the instructions in this manual to preserve safety protections.



WARNING: If this instrument is not installed and used in accordance with this instructions, the protection provided by it against hazards may be impaired.

To meet the requirements of EN 61010-1 standard, where the unit is permanently connected to main supply, it is obligatory to install a circuit breaking device easy reachable to the operator and clearly marked as the disconnecting device.

To guarantee electromagnetic compatibility, the following guidelines should be kept in mind:

- Power supply wires should be separately routed from signal wires and **never runned** in the same conduit.
- Use shielded cable for signal wiring.
- Cables section should be $\geq 0.25 \text{ mm}^2$.

Before connecting signal wires, signal type and input range should be verified to be within the right limits. **Do not connect simultaneously more than one input signal to the meter.**

Connections

Basic instrument has two rear connectors **CN1** and **CN2**. If 2RE output option card is installed, two more connectors **CN3** and **CN4** appear. See all four connectors location and their pin out in the right figure. All female provided terminal connectors are of CAGE CLAMP® technology.

Terminals for **CN2** connector admit cables with section from 0.2mm² up to 1.5mm² (AWG 24÷14).

Terminals for **CN1**, **CN3** and **CN4** connectors admit cables with section from 0.08mm² up to 2.5mm² (AWG 28÷12).

To perform wiring connections, strip the cable leaving from 7 to 10mm exposed to air, insert it in the proper terminal while pushing down the key insertion tool to open the clip inside the connector. Release the key tool to fix wire to the terminal.

Proceed in the same way for the rest of terminals. Once all connections are done, plug connectors to the instrument.

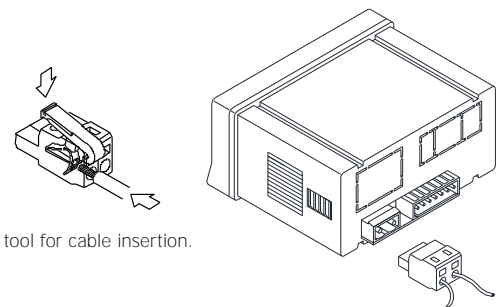
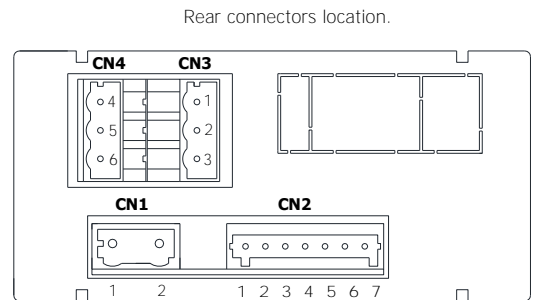

CN4 (relay 2)	
4	NO
5	CM
6	NC

CN3 (relay 1)	
1	NO
2	CM
3	NC

CN1*	
1	Phase (AC)
2	Neutral (AC)

CN2	
1	-IN (COMMON)
2	+IN
3	+EXC 8V DC
4	+EXC 24V DC
5	RESET
6	N.C.
7	IN HIGH (10-600V AC)

Notes:

- NO:** Normally open contact.
- CM:** Common contact.
- NC:** Normally closed contact.
- * Polarity in CN1 is indistinct for DC power.



WARNING

Isolation:

- 1500Vrms for 1 minute to signal terminals (CN2) and power terminals (CN1).
- 2500Vrms for 1 minute to signal terminals (CN2) and relays terminals (CN3 y CN4).
- 2500Vrms for 1 minute to power terminals (CN1) and relays terminals (CN3 y CN4).

Wiring diagram for MAGNETIC sensor / SWITCH CONTACT input signal

CONNECTION DETAIL

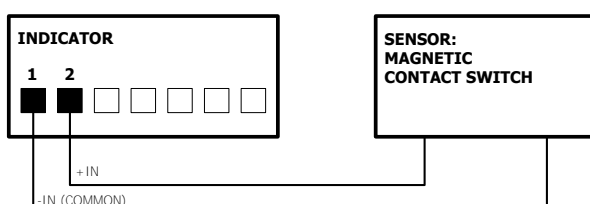

Wiring diagram for NAMUR sensor input signal

CONNECTION DETAIL

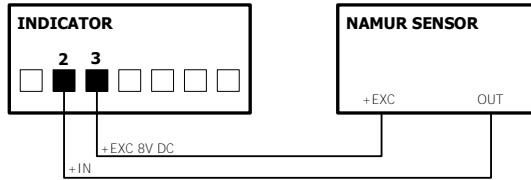

Wiring diagram for NPN, PNP and TTL sensors or 24V DC ENCODER

CONNECTION DETAIL

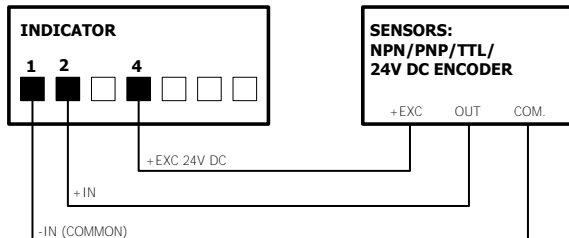

NOTE:

If an external excitation source is used, its common terminal must be connected to the instrument ('-IN (COMMON)' pin 1 of CN2).

High voltage input signal wiring diagram

CONNECTION DETAIL

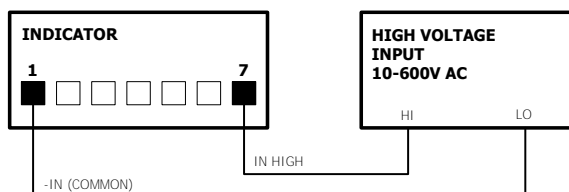

WARNING:

Read recommendations and related data on pages 8 and 9.

Remote counter RESET function wiring diagram

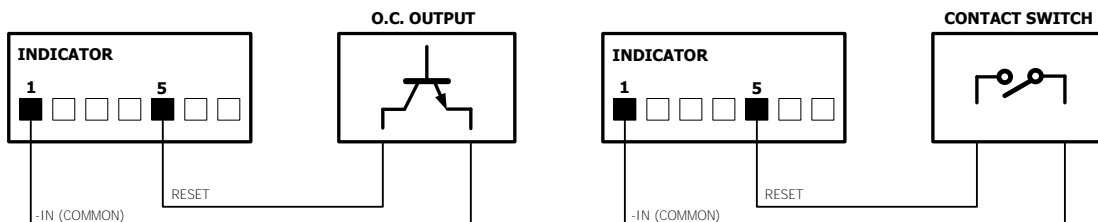

NOTE:

In both cases, main counter RESET is activated through 1 and 5 terminals when contact is closed and it remains active until the contact is again opened .

Remote totalizer RESET is not available.

Relays output wiring

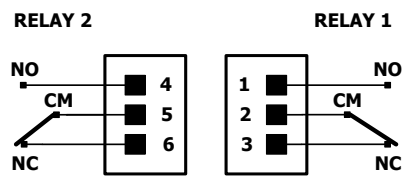

8A/250V MAX.



WARNING:

Read recommendations and related data on pages 8 and 9.

IMPORTANT:

According to EN 61010-1 a protective **8A/250V** external fuse must be installed as a protection against overcurrents.

INPUT CONFIGURATION

Configuration menu

When connecting instrument to Power supply, display test begins automatically to check the good function of LED's and digits, once this test is finished, display shows internal software version and then the unit goes to **RUN** mode.

Configuration software has a hierarchical structure composed of a number of menus and submenus. By pressing **ENTER** key, display shows "**Pro**", a new pressing brings access to main menu where appear configuration menus, that is, input configuration (**InP**), display configuration (**dSP**) and Setpoints configuration (**SEtP**). This last menu only appears if 2RE output option card is installed.

If configuration is totally locked-out, when pressing **ENTER** key to get into main menu, display shows "**dAtA**" instead of "**Pro**". This indicates that it is only possible to see programmed information and that it is not allowed to modify any parameter from the entire configuration. In this visualization mode, the instrument automatically switches back to **RUN** mode after 15 seconds since last key press.

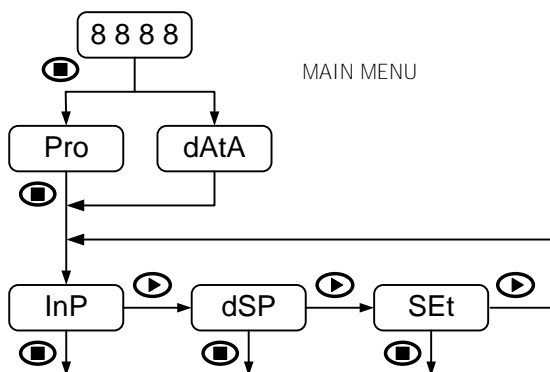

The instrument provides 3 keys for progressing through the menus and submenus and for data introducing/modifying:

- ENTER**: Vertical displacement / Validates data.
- UP**: Increases active digit value.
- SHIFT**: Horizontal displacement / Changes active digit.

Once inside each menu, all configuration parameters are sequentially shown and they can then be introduced or edited by pressing **ENTER** key. Numeric values must be entered digit by digit, first selecting digit and then changing its value. When the display reach desired value, a new **ENTER** key pressing validates data and routine goes forward to next configuration step.

Data entered or changes made during configuration are stored in device memory only when programming routine belonging to the respective submenu is completed, not before. On last routine step and after having pressed **ENTER** key, display indicates "**Store**" and the unit goes back again to **RUN** mode.

Input configuration

The first menu corresponds to input configuration. This, in turn, consists of seven options, one for each input signal type: (-1-), (-2-), (-7-)

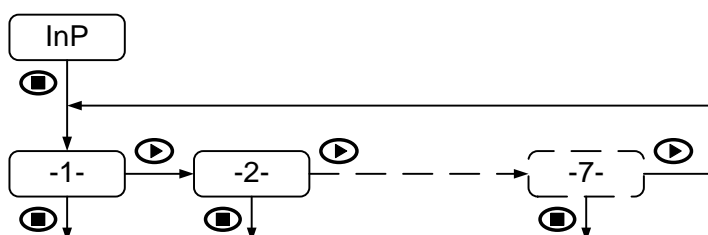

SIGNAL TYPE:

- 1-** : High voltage input (10-600V AC)
- 2-** : Magnetic sensor
- 3-** : NAMUR sensor
- 4-** : PNP sensor
- 5-** : NPN sensor
- 6-** : TTL input / 24V DC ENCODER
- 7-** : Contact switch

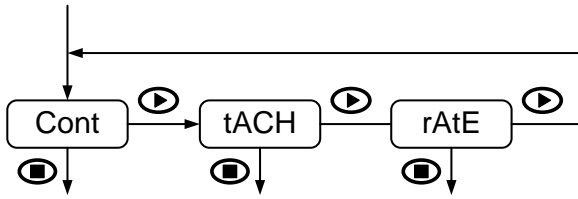

OPERATING MODE:

Once input signal type is chosen and **ENTER** key is pressed, display shows sequentially by pressing repeatedly **SHIFT** key the three available operating modes: Counter (**Cont**), rpm meter (**tACH**) and rate meter (**rAtE**).

In **counter** mode the instrument always counts up the number of pulses received at the input. Totalizer function is also available as an informative data.

In **rpm tachometer** mode speed is always displayed in rpm from the specified number of pulses per revolution given by the sensor.

In **rate tachometer** mode display scaling is possible from an input value given in pulses per second (input frequency) to configure a display-frequency ratio reading in engineering units.

For more detailed configuration and operating options, see later on this manual, display and Setpoints configuration and related available functions.

DISPLAY CONFIGURATION

Display Programming

The second menu corresponds to display configuration. This, in turn, consists of a routine that varies depending on the operating mode previously selected during input configuration. In any case, only the related routine will be displayed each time.

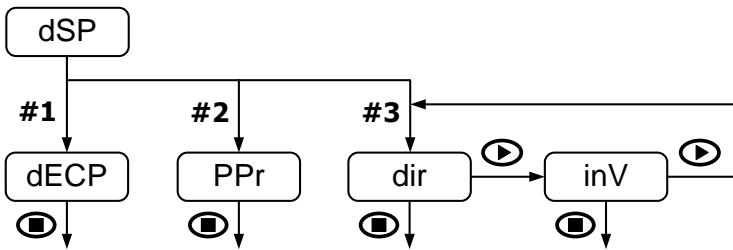

All display configuration values and parameters are **manually** introduced using frontal keys.

Counter mode (#1)

If selected operating mode is counter (**Cont**), the displayed routine after pressing **ENTER** will be the one on the left.

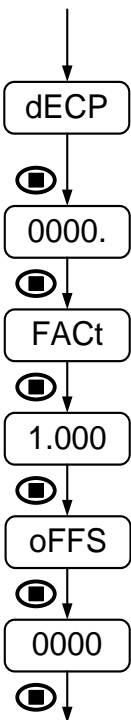

First thing to configure is decimal point position. After "**dECP**" indication, decimal point position is shown at the right end that means no decimal point. Press **SHIFT** key several times to locate decimal point in desired position.

After pressing again **ENTER**, "**FACT**" indication is displayed, configurable factor, and then "**1.000**" with first of the four digits flashing. This factor can be programmed from **0.001** to **9.999**.

Display will increase according to the programmed multiplying factor. This factor is set to "1.000" by default, which makes display match the real number of pulses received at the input. A factor of 0.010 will increase display one count every 100 pulses at the input whereas a factor of 2.000 will increase two counts for every pulse at the input.

Pressing again **ENTER**, display shows "**oFFS**" and then four digits to introduce desired offset value. Offset can be programmed from **0000** to **9999**.

Offset value is shown on display after every time a main counter **RESET** is done.

Once offset value is introduced, press **ENTER** to save changes and to return back to **RUN** mode.

Simplified main counter operation diagram.

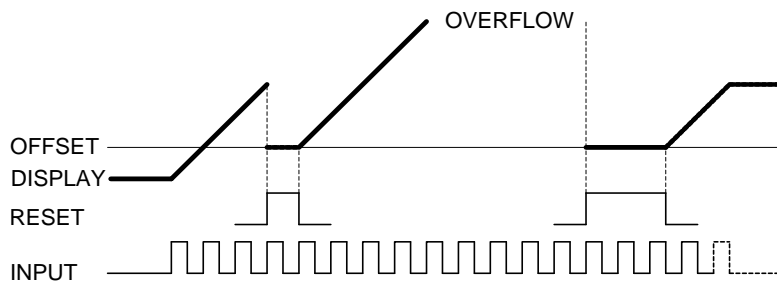

Rpm Tachometer (#2)

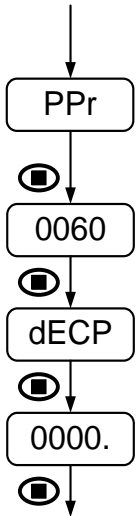

If selected operating mode is rpm tachometer (**tACH**), the displayed routine after pressing **ENTER** will be the one on the left.

First thing to configure is the number of pulses per revolution that provides the sensor connected to the input. After "PPr" indication, display shows four digits (by default 0060) and the possibility to enter the number that must be between **0001** and **9999**.

When pressing **ENTER** again, display shows "dECP" and then "0000." to locate decimal point position. It is possible to choose one decimal position or simply no decimal point by pressing **SHIFT** key.

This operating mode always implies a **rpm** (revolutions per minute) reading and display scaling it is not available.

Press again **ENTER** to save changes and to return back to **RUN** mode.

Rate Tachometer (#3)

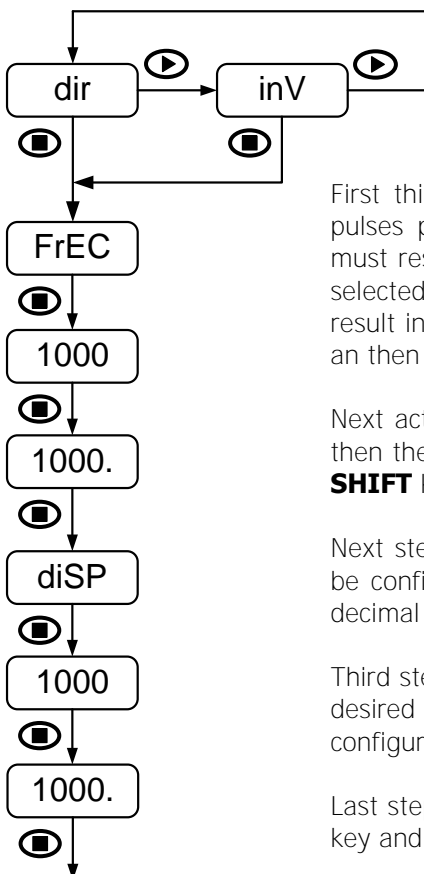

If selected operating mode is rate tachometer (**rAtE**), the displayed routine after pressing **ENTER** will be the one on the left.

First thing to configure is the relation between display reading and the number of pulses per second received at the input (input frequency). If increasing frequency must result in an increasing display then "**dir**" (direct proportional variation) must be selected. Select "**inV**" (reverse proportional variation) if increasing frequency must result in a decreasing display or vice-versa. Select desired variation using **SHIFT** key and then press **ENTER**.

Next action then is to define display scaling in four steps. Display shows "**FrEC**" and then the number of pulses per second at the input must be introduced using **UP** and **SHIFT** keys (1000 by default). Press **ENTER** to accept input frequency value.

Next step defines decimal point position using **SHIFT** key. Frequency resolution can be configured with two (hundredths of a Hertz), one (tenths of a Hertz) or without decimal places (Hz). Press **ENTER** to validate decimal point position.

Third step begins with "**diSP**" message and then a four-digit number which will be the desired display that will correspond to the input frequency value 'FrEC' previously configured in first step. Once it is entered (1000 by default) press **ENTER** to accept.

Last step defines display decimal point position. Choose desired location using **SHIFT** key and press again **ENTER** to save changes and to return back to **RUN** mode.

EXAMPLE OF CONFIGURATION:

It is desired to measure the speed in m/s of a conveyor belt which is driven by a shaft turning at 300 rpm that has 20 cm of diameter and provides 4 pulses per revolution.

In 1 second the shaft will generate 20 pulses (300 rpm = 5 rev/s and each revolution provides 4 pulses). Input frequency is then **20Hz**. Belt lineal speed is **3.142 m/s** ($v = e/t$; $v = 5 \text{ rev} \times \pi \times 0.2 \text{ m/1 s}$). The parameters to be configured will be:

Direct proportional variation (**dir**) ; "FrEC": **0020** ; (no decimal point) ; "diSP": **3142** ; decimal point: 3.142

EXAMPLES OF CONFIGURATION OPERATING AS FREQUENCY METER:

It is possible to operate as a frequency meter configuring the instrument as tachometer (rAtE) and scaling display properly.

For a mains frequency measurement (**50Hz**), using high voltage input the parameters to configure could be: direct proportional variation (**dir**) ; "FrEC": **0500** ; decimal point: 050.0 ; "diSP": **0500** ; decimal point: 050.0

For a frequency of **20kHz** measurement, the parameters to configure could be: direct proportional variation (**dir**) ; "FrEC": **1000** ; (**no decimal point**) ; "diSP": **0010** ; decimal point: 001.0

Average measurement maximum time (tMAH) and time limit (tLiM) (tachometer mode only)

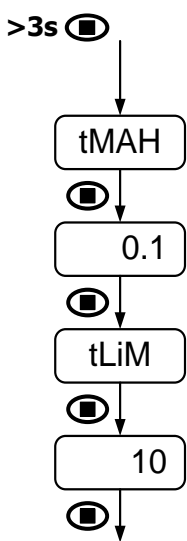

The instrument configured as tachometer with parameters properly programmed ("PPr" and "dCP" for **rpm** mode and "FrEC" and "diSP" for **rate** mode) should operate correctly. However, depending on the sensor type, it may be necessary to modify internal measurement times.

After defining decimal point position at the end of the two configuration routines for **rpm** and **rate** modes, it is possible to access the routine that is shown on the left to modify "tMAH" and "tLiM" parameters by pressing ENTER for at least 3 seconds.

AVERAGE MEASUREMENT MAXIMUM TIME "tMAH"

With irregular input signals, display may present fluttering or unwanted variations due that the number of input cycles detected at each reading are not equal.

"tMAH" parameter allows to extend the average measurement time in seconds to increase taken signal periods during measurement time, reducing the possibility of display variations. A value of 0.0 means that no average will be made and every measure will be displayed. This parameter can be programmed from **0.1** to **9.9** seconds (0.1s by default).

To help stabilizing the display in case of irregular input signals it is recommended to increment this parameter, taking into account that the display readout will be updated at the programmed time. This parameter can be reduced, if the input signal is stable at operating frequency, to increment the display refresh rate.

Once tMAH value is entered, press again **ENTER** to move to the next step.

TIME LIMIT "tLiM"

Time limit, programmable from **1** to **99** seconds (10s by default), allows to limitate waiting time until at least 1 pulse is received at the input before considering it to be 'zero'. If no pulse is detected before programmed time is elapsed, the display goes to zero.

Decreasing time limit makes instrument be able to respond more quickly to the zero condition when system stops but, this reduction leads to an increment of the minimum displayable reading before display goes to zero. The value for this parameter must be always greater or equal to possible minimum period of input signal.

Once tLiM value is entered, press again **ENTER** to save changes.

SETPOINTS CONFIGURATION

Setpoints configuration

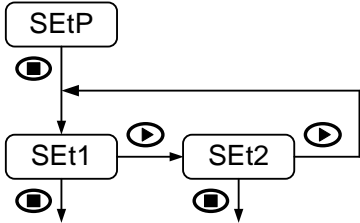

The third menu "SEtP" only appears when two relays output card is installed. For further details on **function modes** please refer to the corresponding **OUTPUT OPTION** part later on this manual.

Programming steps are similar for both relays on each "SEt1" and "SEt2" submenus. The parameters to be configured are the following:

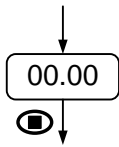

SETPOINT VALUE:

00.00: Value entering in counts within available model display range.

(Is not possible to change decimal point position, which is the previously defined in display configuration menu).

Counter mode ('Cont')

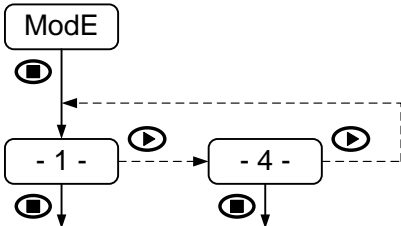

CONTROL MODES (FOR SETPOINT 2 ONLY):

- MODE 1:** INDEPENDENT
- MODE 2:** STOP
- MODE 3:** RESET
- MODE 4:** CLEAR

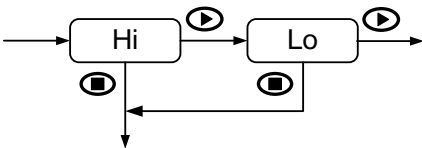

ACTIVATING MODE:

- Hi:** High level relay activation.
- Lo:** Low level relay activation.

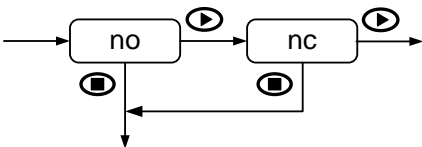

RESTING CONTACTS STATE:

- no:** Normally open contact.
- nc:** Normally closed contact.

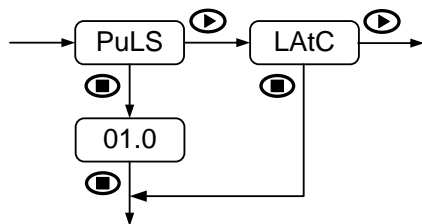

PULSE OR LATCHED OUTPUT:

- PuLS:** Pulse output with activation time configurable from **0.1** to **99.9s**.
- LAtC:** Latched output.

Tachometer mode ('tACH' and 'rAtE')

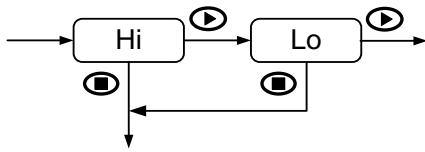

ACTIVATING MODE:

Hi: High level relay activation.
Lo: Low level relay activation.

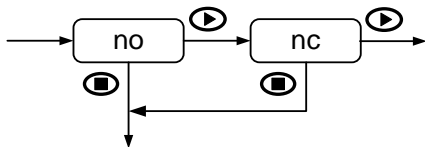

RESTING CONTACTS STATE:

no: Normally open contact.
nc: Normally closed contact.

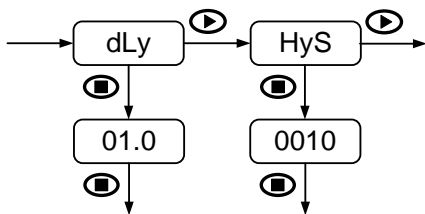

TIME DELAY AND HYSTERESIS:

dLy: Programmable delay from **0** to **99.9s**.
HyS: Hysteresis in counts within available model display range.

In both counter and tachometer mode, if 2RE output option card is uninstalled, the instrument keeps Setpoints last configuration in memory, though it can not be visualized.

Thanks to this feature there will be no need to reconfigure relays setting when 2RE output option is again installed if the same configuration is required.

AVAILABLE KEYBOARD FUNCTIONS

In addition to already known functions used to browse through the configuration menus and submenus, introduce and/or modify existing values and parameters, the instrument provides some more added functions.

TOTALIZER, MAX/MIN and RESET functions

Counter mode ('Cont')

TOTALIZER function is available only when operating as a counter and it is not possible to disable it. It consists in a 6-digit counter that increases at every received pulse applying the configured factor.

Totalizer value is displayed after indication "**tot**" when pressing **SHIFT** key in a sequence of two partial readings of three digits each. Decimal point is located in the same position as in main counter. The less significant digits are preceded by a "**L**" whereas the most significant by a letter "**H**". If totalizer range is exceeded, display will directly display "**Oue**". This sequence lasts 15 seconds, alternating low and high readings (if most significant digits are null they will not be shown). If **SHIFT** key is not again pressed, the instrument will automatically switch back to **RUN** mode after that time.

Main counter **RESET** function activates only in **RUN** mode by pressing **UP** key (or closing contact between 1 and 5 pins of CN2 connector, see page 10) and remains active until this key is released. Main counter **RESET** sets display to zero or to configured OFFSET value.

TOTALIZER RESET function activates while visualizing totalizer value, **SHIFT** key is pressed for at least 3 seconds. After this time zero is displayed. This function always sets totalizer value to zero since there is no associated OFFSET available for it and does not affect the main counter either.

Tachometer mode ('tACH' and 'rAtE')

This device detects and stores in memory maximum and minimum values reached by the input signal. These values remain in memory although power supply is removed, as well. When pressing repeatedly **SHIFT** key, **MAX/MIN** function shows saved maximum and minimum values in display since last **RESET** function activation.

In order to differentiate these values indication from a mode **RUN** indication, decimal point blinks during the time these values are shown. The unit automatically switches back to **RUN** mode after 15 seconds have elapsed since the last key press.

First **SHIFT** key pressing shows "**MAH**" in display followed by the maximum value, a second pressing now shows "**Min**" followed by the minimum value and finally, a third pressing shows "**run**" to back again in an instant to **RUN** mode.

MAX/MIN RESET function activates when visualizing maximum or minimum values **SHIFT** key is pressed for at least 3 seconds. If maximum is the displayed value, current input signal value will replace the previous maximum saved value. In the same way, current input signal will replace saved minimum value while is the minimum the displayed value.

Direct access to Setpoints value

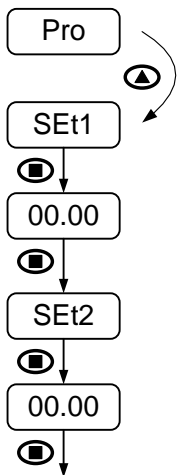

If 2RE output option is installed, it is possible to access to Setpoints value configuration without having to enter main menu.

To access this submenu, from **RUN** mode and after **ENTER** key is pressed, simply press **UP** key while "Pro" is displayed.

FIRST SETPOINT VALUE:

SEt1: Setpoint 1 value indication.

00.00: Value entering in counts within available model display range.

SECOND SETPOINT VALUE:

SEt2: Setpoint 2 value indication.

00.00: Value entering in counts within available model display range.

Return to default configuration

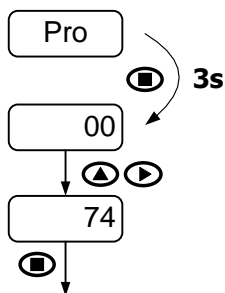

To access this menu from **RUN** mode, press **ENTER** key and while display shows "Pro" press again **ENTER** for at least 3 seconds.

Display shows now "00" and '74' code must be introduced through **SHIFT** and **UP** keys.

Finally press **ENTER** to validate configuration and back to **RUN** mode.

Access to lock-out configuration menu

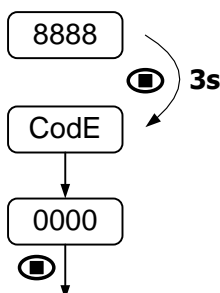

To access this menu from **RUN** mode, press **ENTER** key for at least 3 seconds.

Display shows now "CodE" and then "0000". Desired security code must be introduced through **SHIFT** and **UP** keys (by default this code is **0000**).

Finally press **ENTER** to begin with lock-out level configuration. If entered security code is wrong, the instrument will go back to **RUN** mode.

CONFIGURATION LOCK-OUT

Lock-out menu

In order to prevent accidental or undesirable modifications of instrument parameters, a selective or total configuration lock-out is available. By default the unit is delivered unlocked, giving access to all programming levels. Once in this menu, the first option will be to choose between lock-out level setting ("LiSt") or security access code changing ("CHAn").

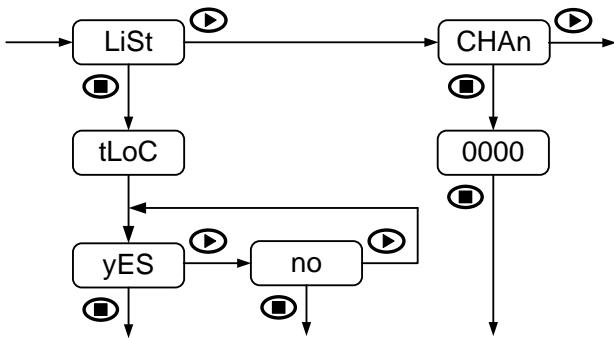

If "LiSt" option is selected, display will show momentarily "tLoc". Total configuration lock-out is activated by selecting "yES", then routine directly jumps to RESET function and SHIFT key for MAX/MIN function lock-out configuration before the unit goes back to RUN mode. **When total lock-out is set, no data can be entered or modified**, although it will still be possible to visualize all programmed parameters. Under these conditions when entering main menu, initial indication will be "dAtA" instead of "Pro".

On the other hand, when "no" option is selected, routine move on to next step to configure a partial lock-out. **When a partial lock-out is set, only non-locked data can be entered or modified**. Under these conditions when entering main menu, initial indication will be "Pro".

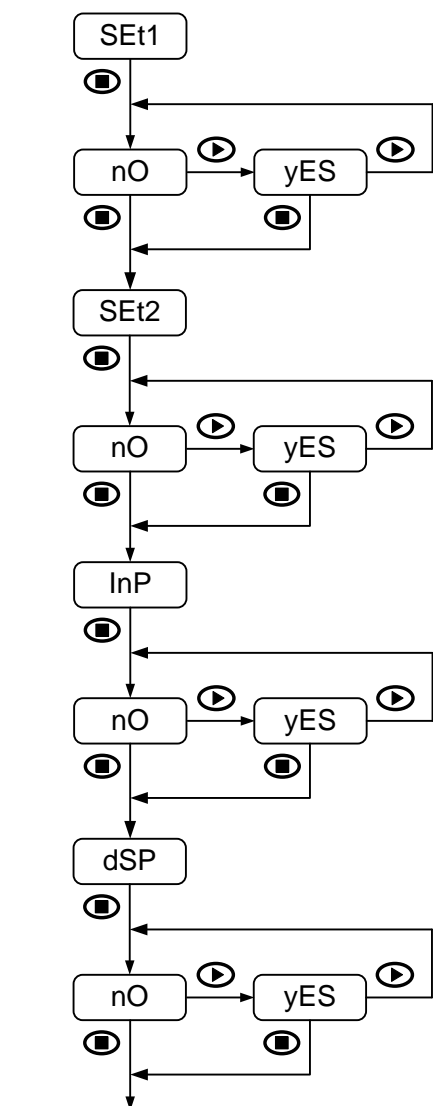

The following configuration access can be locked-out:

- Setpoint 1 configuration (SEt1)
- Setpoint 2 configuration (SEt2)
- Input configuration (InP)
- Display configuration (dSP)
- RESET function configuration (rSt)
- SHIFT key configuration for MAX/MIN function (MAH)

In each case lock-out is activated by selecting "yES" option and deactivated by selecting "no".

Setpoints 1 and 2 configuration lock-out is available only when 2RE output is installed.

RESET function configuration lock-out (rSt) is available only when operating as counter ('Cont').

SHIFT key for MAX/MIN function configuration lock-out (MAH) is available only when operating as tachometer ('TACH' or 'rAtE').

If 2RE output option card is uninstalled, the instrument keeps Setpoints last configuration in memory, though it can not be visualized. There will be no need to reconfigure Setpoints lock-out when 2RE output option is again installed if the same configuration is required.

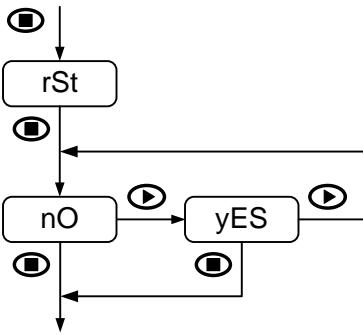

RESET function activated through UP key can be blocked, as well (only when operating as counter 'Cont').

NOTE:

Totalizer RESET function lock-out is not available and it will always remain active.

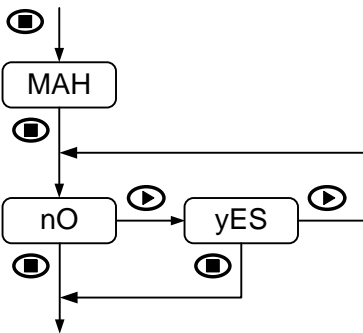

SHIFT key lock-out for MAX/MIN function is configurable in the same way as previous configurations (only when operating as tachometer 'tACH' or 'rAtE').

When lock-out is enabled (selecting "yES") it is not possible to visualize maximum or minimum values by pressing SHIFT key, although instrument internally continues detecting and saving new extreme values reached by input signal.

Once the instrument programming is completed, if there are parameters that are going to be frequently changed, a partial lock-out is recommended. A total lock-out is recommended when configuration parameters will be constant for a long time.

Changing default security code and keep new one in a safe place is also strongly recommended.

OUTPUT OPTION

Description

2RE output option allows JR-D and JR20-D models to perform control operations and limit values treatment via ON/OFF logic outputs. It is supplied as an independent card that is connected to main board without any additional operation since internal software recognizes it once it is installed. There is no need to read the manual since all information required is contained in this user manual.

Function modes description

Alarms are independent, they become activate when display value reach Setpoint level programmed by the user (Setpoints can **not** be referred to the totalizer). For a correct configuration it will be necessary to define function mode, as well.

HI/LO mode activation

In **HI** mode, output activates when display value goes above Setpoint level, whereas in **LO** mode, output activates when display value falls below Setpoint level.

Time delay (Tachometer mode 'tACH' and 'rAtE' only)

Both output actions can be deferred by a configurable time delay from 0 up to 99.9 seconds.

Time delay activation starts when display value reach each Setpoint '**SET**' either increasingly or decreasingly, obtaining the '**dly**' delay in output activation/deactivation as right figure shows.

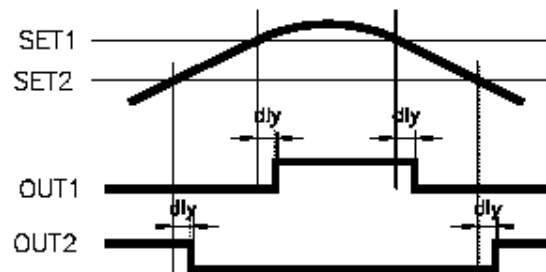

Retardo por temporización para OUT1 en modo **HI** y OUT2 en modo **LO**

Asymmetrical hysteresis (Tachometer mode 'tACH' and 'rAtE' only)

Both output actions can be deferred by a hysteresis level which is configurable in counts within full available display. Decimal point position is the previously defined in display configuration menu.

Asymmetrical hysteresis action only starts in the output deactivation edge, obtaining as a result the '**hys-1**' delay as indicated on the right figure.

Note that outputs activation is not affected by hysteresis and they activate in each case just when Setpoint '**SET**' is reached by display.

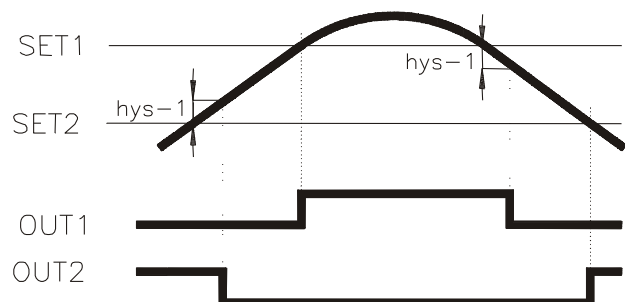

Retardo por histéresis para OUT1 en modo **HI** y OUT2 en modo **LO**

1, 2, 3 and 4 control modes (for counter mode 'Cont' and Setpoint 2 only)

MODE 1: INDEPENDIENT

Relays will be activated when main counter reaches their respective Setpoint values. They will be deactivated when the necessary conditions are met depending on how output is configured, 'pulse' or 'latched'. Outputs are respectively shown overlapped in right diagrams as or .

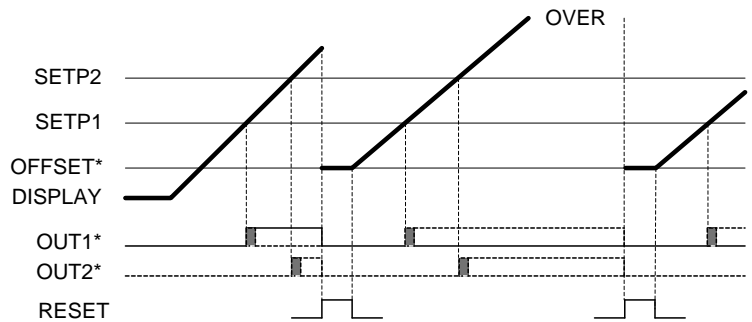

MODE 2: STOP

Relay 1 activates when the main counter reaches its respective Setpoint value and Relay 2 stops when Setpoint 2 is reached. Main counter remains stopped until a RESET is done. Relays will be deactivated when display goes down below their respective Setpoint value.

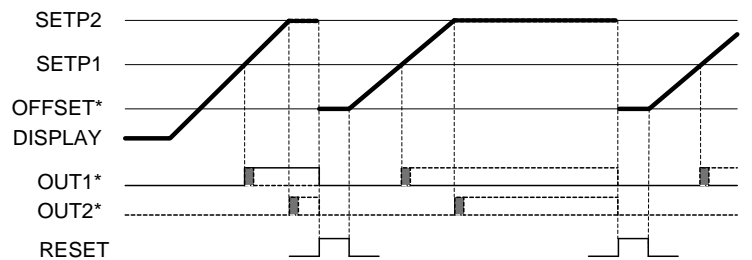

MODE 3: RESET

Relay 1 activates at its Setpoint value. When main counter reaches Setpoint 2, a main counter RESET is done. Relay 2 output is pulse type and remains active for the programmed time. Relay 1 will be deactivated if display goes down below Setpoint 1 value.

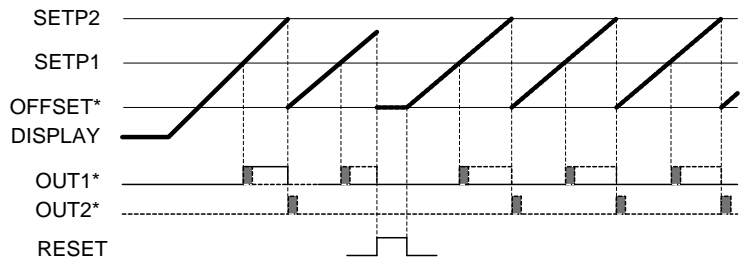

MODE 4: CLEAR

Relay 1 activates at its Setpoint value. When main counter reaches Setpoint 2, relay 2 activates and relay 1 is deactivated (if it was activated). Relay 2 output is latched type. Main counter goes on until a RESET sets display to programmed OFFSET value. Relay 2 will be deactivated if display goes below Setpoint 2.

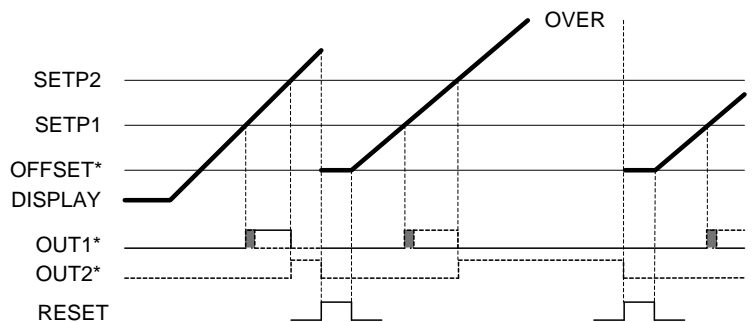

*** In all cases, the behaviour of OUT1 and OUT2 outputs relays, and consequently of the main counter, changes depending on defined OFFSET level.**

Pulse output "PuLS" (Counter mode only 'Cont') ()

Relay activates when its Setpoint is reached by display and deactivates after a period of time. This activation time is a parameter which can be programmed between 0.1s and 9.9s.

Latched output "LAtC" (Counter mode only 'Cont') ()

Relay activates when its Setpoint is reached by display and remains activated until a RESET makes display go below that Setpoint.

Installation

To physically install the output option, the electronics assembly should be first lifted out from the case. Use a screwdriver or similar to slightly press both side tabs until the rear case is released. Then broke the junctions from the corresponding polycarbonate cover in order to obtain the required orifice in the case. This orifice will allow 2RE connectors come out through instrument rear part once it is installed.

Install 2RE option on the indicated location pushing slightly down until both connectors get perfectly together. For best installation, it is recommended to solder this card to the main circuit making use of the copper pads on both sides of its insertion pin and those surrounding the circuit hole where it is inserted in.

Once 2RE is installed, carefully put the circuitry again inside the case verifying that circuits slide properly without much effort through rear case internal guides.

Each output card is supplied with an adhesive label that indicates wiring connections. To help identifying terminals, this label should be placed in the upper side of the unit case. Besides its own connections, there are other output options indications for other outputs that can be installed in other model indicators.

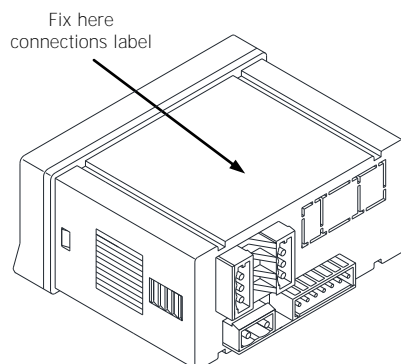
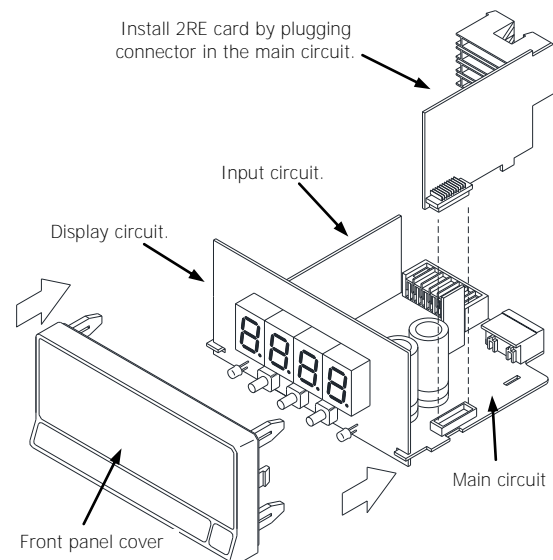
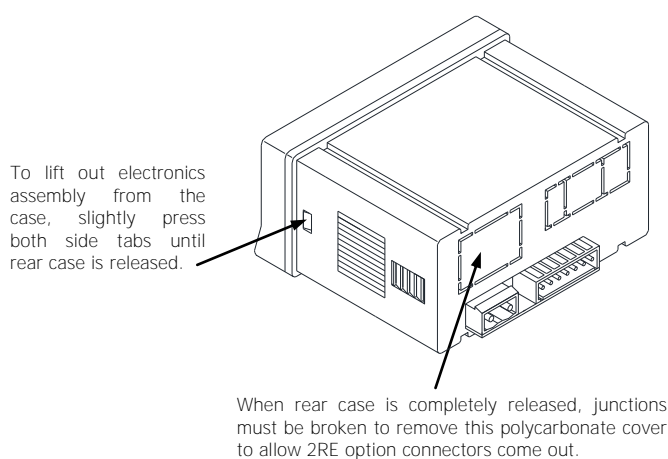

Once 2RE is installed and instrument is again inside the case, 2RE connectors should come out through the obtained orifice as this figure shows.



WARNING:

Disconnect all power and rest of input signals connected to the indicator before installing or extracting the output option card.

SPECIFICATIONS

Technical specifications

SPECIAL FUNCTIONS

Return to factory configuration.
Software configuration lock-out.

PRECISION (tachometer rpm or rate modes)

Temperature coefficient 50ppm/°C
Accuracy $\pm(0.01\% \text{ rdg} + 1\text{d})$
Specifications range $23^{\circ}\text{C} \pm 5^{\circ}\text{C}$
Warm-up time 5 minutes

ALIMENTACIÓN y FUSIBLES (DIN 41661) (no incorporados)

JR-D: 20-265 V AC 50/60 Hz and 11-265 V DC.. F 3A/ 250V
JR20-D: 20-265 V AC 50/60 Hz and 11-265 V DC.. F 3A/ 250V
Power consumption (both models) 3W
Sensor excitation (both models) 8V@60mA ; 24V \pm 3V@30mA

DISPLAY

Ranges:
JR-D 0 ÷ 9999, 14mm RED LED
JR20-D 0 ÷ 9999, 20mm RED LED
Totalizer (counter mode) (both models) 0 ÷ 999999
Decimal point..... Configurable
LEDs 2 for Setpoints state indication
Display refresh rate
(tachometer rpm or rate modes) 0.1s to 9.9s (config.)
Display/frequency overrange indication "OuE"
OFFSET (counter mode) Through frontal key configurable
RESET (counter and totalizer) Through frontal key
Remote RESET (counter) Contact switch / Logic input
MAX./MIN. and MAX./MIN. RESET functions
(tachometer rpm or rate modes) Through frontal key

FILTER (switch contact)

Cutoff frequency (Fc) 20Hz

ENVIRONMENTAL CONDITIONS

Operating temperature $-10^{\circ}\text{C} \div +60^{\circ}\text{C}$
Storage temperature $-25^{\circ}\text{C} \div +85^{\circ}\text{C}$
Relative humidity (non-condensing) $<95\% @ 40^{\circ}\text{C}$
Maximum altitude 2000m
Frontal protection degree IP65

INPUT SIGNAL

Maximum frequency (counter mode) 7.5kHz
Maximum frequency (tachometer rpm or rate modes) 25kHz
Minimum frequency (tachometer rpm or rate modes) 0.01Hz

High voltage input

Range 10V AC to 600V AC

Magnetic sensor

Sensitivity $F \geq 1\text{kHz}$; $V_{in} \text{ min.} \geq 100\text{mV}$

Namur sensor

R_C $1\text{k}\Omega$
 I_{ON} $< 1\text{mA DC}$
 I_{OFF} $> 3\text{mA DC}$

NPN/PNP sensor

R_C $1\text{k}\Omega$
Logic level "0" $< 2.4\text{V DC}$
Logic level "1" $> 2.6\text{V DC}$

TTL/24V encoder

Logic level "0" $< 2.4\text{V DC}$
Logic level "1" $> 2.6\text{V DC}$

Contact switch

V_C 5V
 R_C $3.9\text{k}\Omega$

DIMENSIONS

Dimensions 96 x 48 x 60 mm (1/8 DIN).
Panel cutout 92 x 45 mm.
Weight 150g.
Case material UL 94 V-0 polycarbonate.

2RE OPTION

Maximum switching current (resistive load) 8A
Maximum switching power 2000VA / 192W
Maximum switching voltage 400VAC / 125VDC
Contact rating 8A @ 250VAC / 24VDC
Contact resistance $\leq 100\text{m}\Omega$ at 6V DC @ 1A
Contact type SPDT
Operate time $\leq 10\text{ms}$

NOTE:

In case that the outputs are used to drive inductive loads, it is recommended to add an RC network between the coil terminals (preferably) or between the relay contacts, to limit electromagnetic effects and to extend contacts life.

NOTES:

INSTRUMENT CONFIGURATION

Use the following template for the annotation of configured parameters in your instrument for later consulting or data recover.

INPUT:

TYPE:

MODE: CONT TACH RATE

DISPLAY:

MULT. FACTOR:

OFFSET:

PPR:

DISP. VARIATION: DIR INV

INPUT FREQUENCY:

DISPLAY:

TMAX.:

TLIM.:

SETPOINTS:

SET1:

ACT. MODE: no nc

DLY / PULSE TIME: /

HYS / LATCH: /

SET2:

CONTROL MODE:

ACT. MODE: no nc

DLY / PULSE TIME: /

HYS / LATCH: /

LOCK-OUT:

ACCESS CODE:

