



**GUIA RÁPIDA DE INSTALACIÓN**  
**GUIDE RAPIDE D'INSTALLATION**  
**QUICK INSTALLATION GUIDE**  
**SCHNELL-INSTALLIERUNGSANLEITUNG**



Indicador digital con entrada para:  
 TENSION DC ( $\pm 600V$ ,  $\pm 200V$  y  $\pm 20V$ )  
 CORRIENTE DC ( $\pm 5A$ ,  $\pm 1A$ ,  $\pm 100mV$  y  $\pm 60mV$ )  
 TENSION AC (0-600V, 0-200V y 0-20V)  
 CORRIENTE AC (0-5A, 0-1A, 0-100mV y 0-60mV)

Indicateur digitale pour signaux d'entrée:  
 TENSION DC ( $\pm 600V$ ,  $\pm 200V$  et  $\pm 20V$ )  
 COURANT DC ( $\pm 5A$ ,  $\pm 1A$ ,  $\pm 100mV$  et  $\pm 60mV$ )  
 TENSION AC (0-600V, 0-200V et 0-20V)  
 COURANT AC (0-5A, 0-1A, 0-100mV et 0-60mV)

Digital indicator for input signal:  
 DC VOLTAGE ( $\pm 600V$ ,  $\pm 200V$  and  $\pm 20V$ )  
 DC CURRENT ( $\pm 5A$ ,  $\pm 1A$ ,  $\pm 100mV$  and  $\pm 60mV$ )  
 AC VOLTAGE (0-600V, 0-200V and 0-20V)  
 AC CURRENT (0-5A, 0-1A, 0-100mV and 0-60mV)

Digitalanzeige für Eingangssignal:  
 DC-SPANNUNG ( $\pm 600V$ ,  $\pm 200V$  und  $\pm 20V$ )  
 DC-STROM ( $\pm 5A$ ,  $\pm 1A$ ,  $\pm 100mV$  und  $\pm 60mV$ )  
 AC-SPANNUNG (0-600V, 0-200V und 0-20V)  
 AC-STROM (0-5A, 0-1A, 0-100mV und 0-60mV)

**Tensión DC. Tension DC. DC Voltage. DC-Spannung.**

Rango Plage Range Bereich	$\pm 20V$	$\pm 200V$	$\pm 600V$
Impedancia de entrada Impédance d'entrée Input impedance Eingangsimpedanz	100k $\Omega$	1M $\Omega$	3M $\Omega$
Sobrecarga máxima Surcharge maximale Maximum overload Maximale Überlast	100V	600V	1000V
Precisión Précision Accuracy Genauigkeit	$\pm(0.05\% \text{ rdg} + 25mV)$	$\pm(0.05\% \text{ rdg} + 250mV)$	$\pm(0.05\% \text{ rdg} + 0.7V)$

**Corriente DC. Courant DC. DC Current. DC-Strom.**

Rango Plage Range Bereich	$\pm 1A$	$\pm 5A$	Shunt $\pm 60mV$	Shunt $\pm 100mV$
Impedancia de entrada Impédance d'entrée Input impedance Eingangsimpedanz	70m $\Omega$	14m $\Omega$	2.5k $\Omega$	2.5k $\Omega$
Sobrecarga máxima Surcharge maximale Maximum overload Maximale Überlast	1.2A	7A	20V	20V
Precisión Précision Accuracy Genauigkeit	$\pm(0.05\% \text{ rdg} + 1mA)$	$\pm(0.05\% \text{ rdg} + 6mA)$	$\pm(0.05\% \text{ rdg} + 70\mu V)$	$\pm(0.05\% \text{ rdg} + 120\mu V)$

**Tensión AC. Tension AC. AC Voltage. AC-Spannung.**

Rango Plage Range Bereich	0-20V	0-200V	0-600V
Impedancia de entrada Impédance d'entrée Input impedance Eingangsimpedanz	100k $\Omega$	1M $\Omega$	3M $\Omega$
Sobrecarga máxima Surcharge maximale Maximum overload Maximale Überlast	100V	600V	1000V
Precisión Précision Accuracy Genauigkeit	$\pm(0.1\% \text{ rdg} + 30mV)$ (45Hz-1kHz)	$\pm(0.25\% \text{ rdg} + 0.3V)$ (45Hz-1kHz)	$\pm(0.35\% \text{ rdg} + 0.9V)$ (45Hz-1kHz)

**Corriente AC. Courant AC. AC Current. AC-Strom.**

Rango Plage Range Bereich	0-1A	0-5A	Shunt 0-60mV	Shunt 0-100mV
Impedancia de entrada Impédance d'entrée Input impedance Eingangsimpedanz	70m $\Omega$	14m $\Omega$	2.5k $\Omega$	2.5k $\Omega$
Sobrecarga máxima Surcharge maximale Maximum overload Maximale Überlast	1.2A	7A	20V	20V
Precisión Précision Accuracy Genauigkeit	$\pm(0.1\% \text{ rdg} + 5mA)$ (45Hz-1kHz)	$\pm(0.1\% \text{ rdg} + 20mA)$ (45Hz-1kHz)	$\pm(0.1\% \text{ rdg} + 300\mu V)$ (45Hz-1kHz)	$\pm(0.1\% \text{ rdg} + 300\mu V)$ (45Hz-1kHz)

**Conformidad CE. Conformité CE. CE Conformity. CE-Konformität**

Directivas Directives Directives Richtlinien	EMC 2004/108/EC	LVD 2006/95/EC
Normas Normes Standards Normen	EN 61326-1	EN 61010-1



Según la Directiva 2002/96/CE, no puede deshacerse de este aparato como un residuo urbano normal. Puede devolverlo, sin coste alguno, al lugar donde fue adquirido para que de esta forma se proceda a su tratamiento y reciclado controlados.  
 Selon la Directive 2002/96/CE, l'utilisateur ne peut se défaire de cet appareil comme d'un résidu urbain courant. Vous pouvez le restituer, sans aucun coût, au lieu où il a été acquis afin qu'il soit procédé à son traitement et recyclage contrôlés.  
 According to 2002/96/CE Directive, You cannot dispose of it at the end of its lifetime as unsorted municipal waste. You can give it back, without any cost, to the place where it was acquired to proceed to its controlled treatment and recycling.  
 Gemäß der Richtlinie 2002/96/EG darf dieses Elektronikgerät nicht über den herkömmlichen Haushaltsmüllkreislauf entsorgt werden. Sie kann das Gerät kostenlos an die Stelle von der es erworben wurde, für die kontrollierte Bearbeitung und Wiederverwertung zurückgeben.

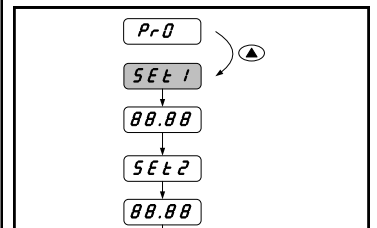
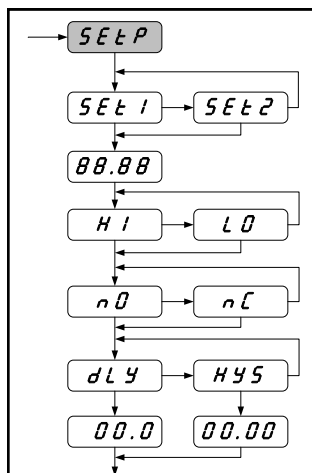
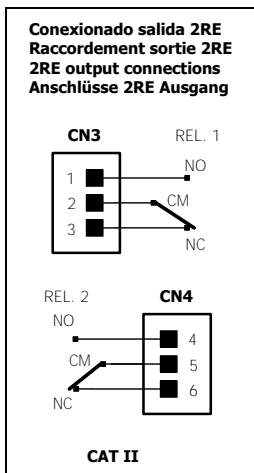
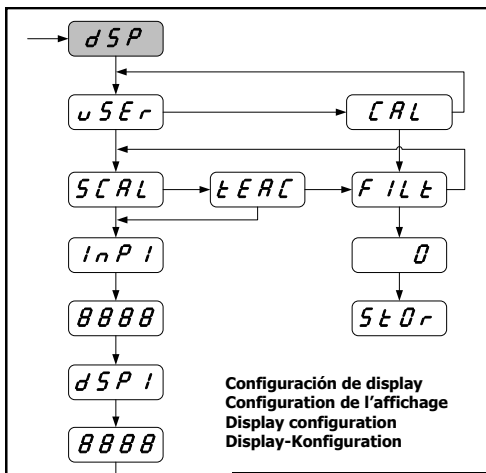
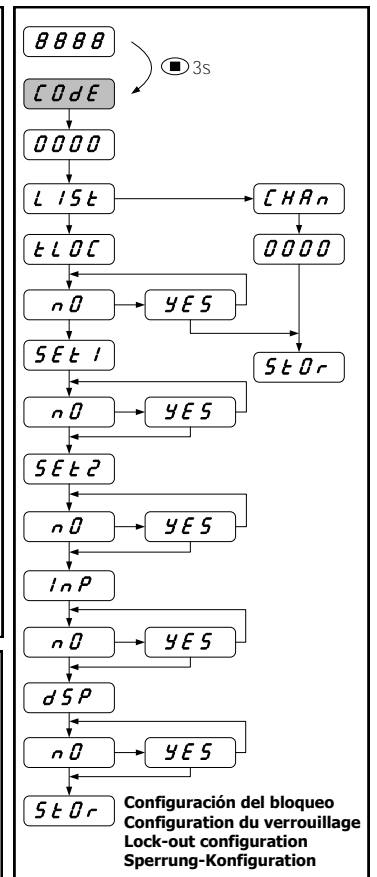
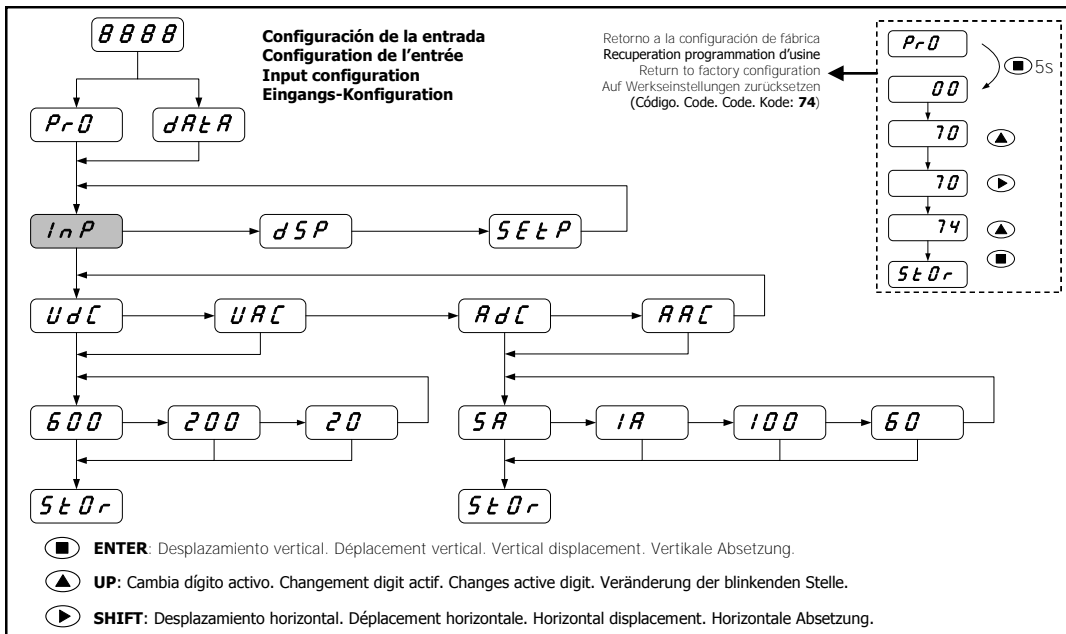

Corriente máxima. Courant maximal.  
Maximum current. Maximale Strom.

Fusible recomendado. Fusible recommandé.  
Recommended fuse. Empfohlene Sicherung.

**8A/250V**

**\*\* IMPORTANTE! / IMPORTANT! / WICHTIG!**

Para garantizar la seguridad eléctrica de acuerdo con EN 61010-1 deberá instalarse como medida de protección un fusible externo.

Pour garantir la sécurité électrique selon EN 61010-1 il faut installer un fusible externe de protection.

To guarantee electrical safety according to EN 61010-1 a protective external fuse must be installed.

Um die elektrische Sicherheit nach EN 61010-1 zu garantieren, muss eine externe Sicherung installiert werden.

