



**GUIA RÁPIDA DE INSTALACIÓN
GUIDE RAPIDE D'INSTALLATION
QUICK INSTALLATION GUIDE
SCHNELL-INSTALLIERUNGSANLEITUNG**

Indicador digital con entrada para:
CÉLULA DE CARGA ($\pm 300\text{mV}$ ó $\pm 30\text{mV}$)

Indicateur digitale pour signaux d'entrée:
CELLULE DE CHARGE ($\pm 300\text{mV}$ ou $\pm 30\text{mV}$)

Digital indicator for input signal:
LOAD CELL ($\pm 300\text{mV}$ or $\pm 30\text{mV}$)

Digitalanzeiger für Eingangssignal:
DMS SENSOREN ($\pm 300\text{mV}$ oder $\pm 30\text{mV}$)



Datos técnicos. Données techniques. Technical data. Technische Daten.

Rango Plage Range Bereich	$\pm 30\text{mV}$	$\pm 300\text{mV}$
Señal máxima de entrada Signale d'entrée maximale Maximum input signal Maximale Eingangssignal	$\pm 32\text{mV}$	$\pm 320\text{mV}$
Impedancia de entrada Impédance d'entrée Input impedance Eingangsimpedanz	3M Ω	
Límites de display Échelle d'affichage Display limits Anzeigebereich	-9999...+9999 (JR-C) -1999...+9999 (JR20-C)	
Excitación Excitation Excitation Speisung	5V / 10V (30mA max.)	
Función TARA Fonction TARE TARE function TARA Funktion	Entrada lógica ó por teclado Entrée logique ou par clavier Logic input or by keyboard Logische-Eingang oder über Tastatur	
Precisión Précision Accuracy Genauigkeit	$\pm(0.05\% \text{ rdg} + 6\mu\text{V})$	$\pm(0.05\% \text{ rdg} + 60\mu\text{V})$

Conformidad CE. Conformité CE. CE Conformity. CE-Konformität.

Directivas Directives Directives Richtlinien	EMC 2004/108/EC	LVD 2006/95/EC
Normas Normes Standards Normen	EN 61326-1	EN 61010-1



Según la Directiva 2002/96/CE, no puede deshacerse de este aparato como un residuo urbano normal. Puede devolverlo, sin coste alguno, al lugar donde fue adquirido para que de esta forma se proceda a su tratamiento y reciclado controlados.
Selon la Directive 2002/96/CE, l'utilisateur ne peut se défaire de cet appareil comme d'un residu urbain courant. Vous pouvez le restituer, sans aucun coût, au lieu où il a été acquis afin qu'il soit procédé à son traitement et recyclage contrôlés.
According to 2002/96/CE Directive, You cannot dispose of it at the end of its lifetime as unsorted municipal waste. You can give it back, without any cost, to the place where it was acquired to proceed to its controlled treatment and recycling.
Gemab der Richtlinie 2002/96/EG darf dieses Elektronikgerät nicht über den herkömmlichen Haushaltsmüllkreislauf entsorgt werden. Sie kann das Gerät kostenlos an die Stelle von der es erworben wurde, für die kontrollierte Bearbeitung und Wiederverwertung zurückgeben.

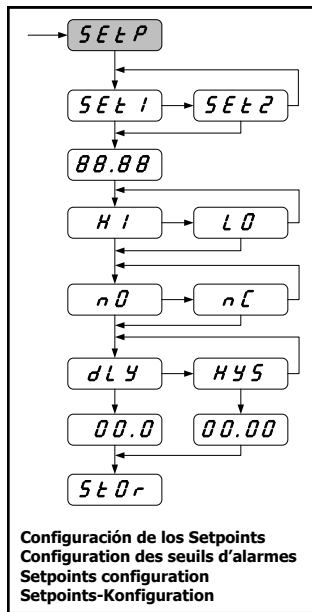
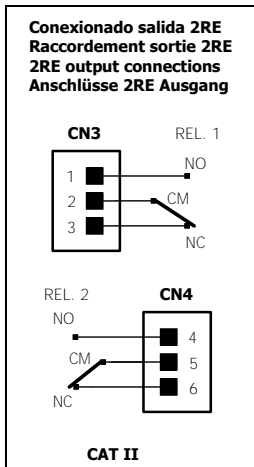
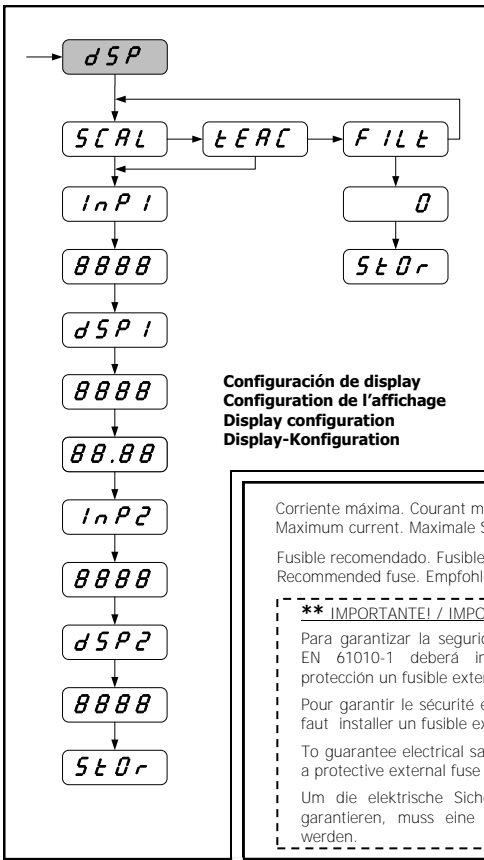
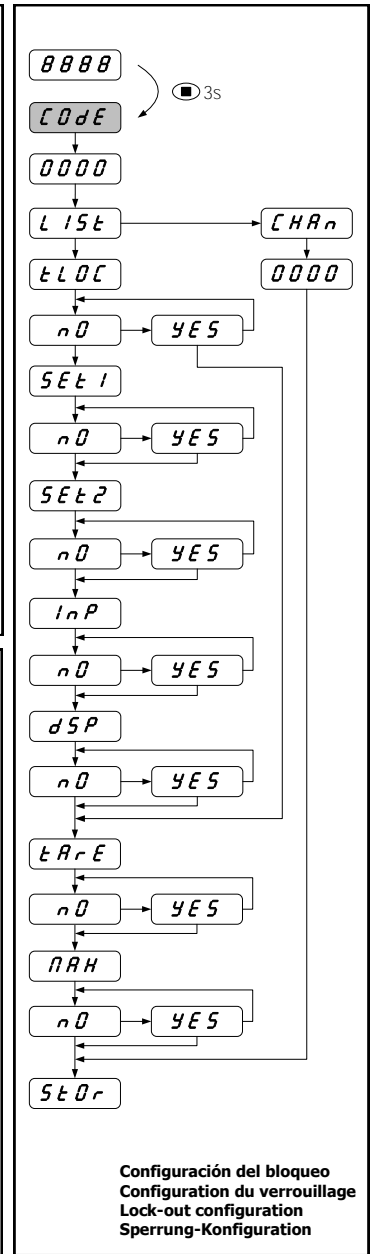
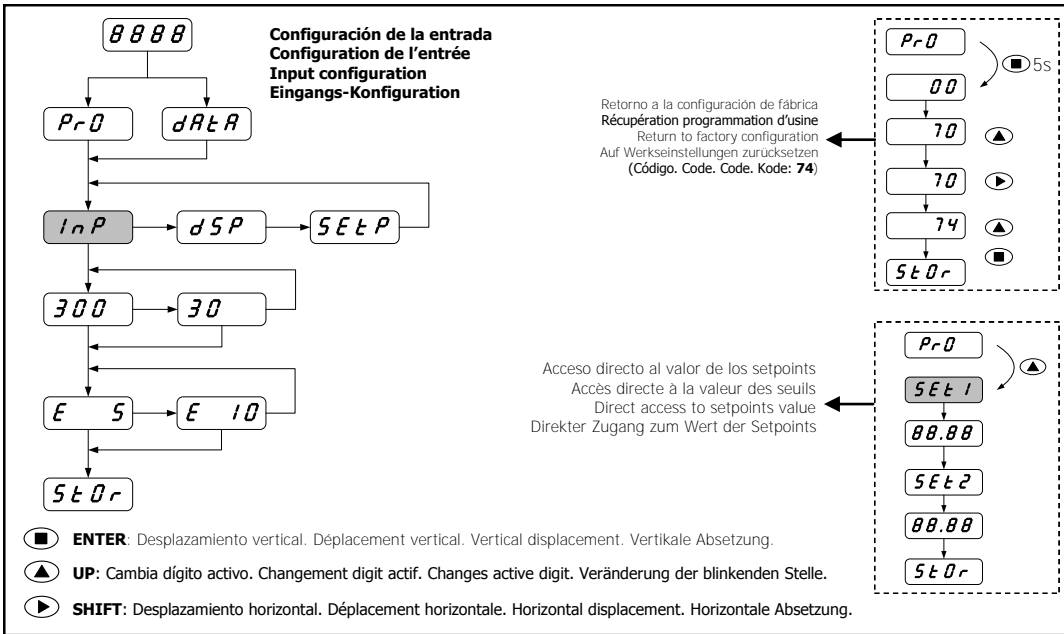

Corriente máxima. Courant maximal.
Maximum current. Maximale Strom. **8A**
(250V AC/24V DC)

Fusible recomendado. Fusible recommandé.
Recommended fuse. Empfohlene Sicherung. **8A**

**** IMPORTANTE! / IMPORTANT! / WICHTIG!**

Para garantizar la seguridad eléctrica de acuerdo con EN 61010-1 deberá instalarse como medida de protección un fusible externo.

Pour garantir la sécurité électrique selon EN 61010-1 il faut installer un fusible externe de protection.

To guarantee electrical safety according to EN 61010-1 a protective external fuse must be installed.

Um die elektrische Sicherheit nach EN 61010-1 zu garantieren, muss eine externe Sicherung installiert werden.

