



	<b>DK</b>	Side 1
	<b>UK</b>	Page 21
	<b>FR</b>	Page 41
	<b>DE</b>	Seite 61

# 9203

## Solenoid / alarm driver

No. 9203V101-IN (1014)  
Product version: 9203-001



**SIGNALS THE BEST**

**MTS** **Messtechnik  
Schaffhausen GmbH**  
CH-8260 Stein am Rhein  
Telefon +41 52-672 50 00

- DK** ▶ PR electronics A/S tilbyder et bredt program af analoge og digitale signalbehandlingsmoduler til industriel automation. Programmet består af Isolatorer, Displays, Ex-barrierer, Temperaturtransmittere, Universaltransmittere mfl. Vi har modulerne, du kan stole på i selv barske miljøer med elektrisk støj, vibrationer og temperaturudsving, og alle produkter opfylder de strengeste internationale standarder. Vores motto »Signals the Best« er indbegrebet af denne filosofi – og din garanti for kvalitet.
- UK** ▶ PR electronics A/S offers a wide range of analogue and digital signal conditioning modules for industrial automation. The product range includes Isolators, Displays, Ex Interfaces, Temperature Transmitters, and Universal Modules. You can trust our products in the most extreme environments with electrical noise, vibrations and temperature fluctuations, and all products comply with the most exacting international standards. »Signals the Best« is the epitome of our philosophy – and your guarantee for quality.
- FR** ▶ PR electronics A/S offre une large gamme de produits pour le traitement des signaux analogiques et numériques dans tous les domaines industriels. La gamme de produits s'étend des transmetteurs de température aux afficheurs, des isolateurs aux interfaces SI, jusqu'aux modules universels. Vous pouvez compter sur nos produits même dans les conditions d'utilisation sévères, p.ex. bruit électrique, vibrations et fluctuations de température. Tous nos produits sont conformes aux normes internationales les plus strictes. Notre devise »SIGNALS the BEST« c'est notre ligne de conduite - et pour vous l'assurance de la meilleure qualité.
- DE** ▶ PR electronics A/S verfügt über ein breites Produktprogramm an analogen und digitalen Signalverarbeitungsmodulen für die industrielle Automatisierung. Dieses Programm umfasst Displays, Temperaturtransmitter, Ex- und galvanische Signaltrenner, und Universalgeräte. Sie können unsere Geräte auch unter extremen Einsatzbedingungen wie elektrisches Rauschen, Erschütterungen und Temperaturschwingungen vertrauen, und alle Produkte von PR electronics werden in Übereinstimmung mit den strengsten internationalen Normen produziert. »Signals the Best« ist Ihre Garantie für Qualität!

# VENTIL- / ALARMDRIVER

9203

## INDHOLD

Advarsel.....	2
Signaturforklaring .....	2
Sikkerhedsregler.....	2
Afmontering af system 9000 .....	4
EF-Overensstemmelseserklæring .....	5
Avancerede features.....	6
Anvendelse .....	6
Teknisk karakteristik .....	6
Applikationer .....	7
PR 4501 Display- / programmeringsfront .....	8
Bestillingsskema: 9203B.....	9
Elektriske specifikationer.....	9
Hardware- / softwarefejl.....	13
Tilslutninger .....	14
Blokdiagram .....	15
Visning af signalfejl uden displayfront.....	16
Programmering / betjening af trykknapper .....	16
Rutediagram .....	18
Rutediagram, Avancerede indstillinger (ADV.SET) .....	19
Rullende hjælpetekster i displaylinie 3.....	20
Appendix .....	81
IECEx Installation Drawing .....	82
ATEX Installation Drawings, UK, FR, DE, DK.....	84
FM Installation Drawing.....	92
Safety Manual .....	94



## ADVARSEL

Følgende operationer bør kun udføres på modulet i spændingsløs tilstand og under ESD-sikre forhold:

Installation, ledningsmontage og -demontage.

Fejlfinding på modulet.

**Reparation af modulet og udskiftning af sikringer må kun foretages af PR electronics A/S.**



## ADVARSEL

Modulets frontplade må ikke åbnes, da dette vil medføre skade på stikforbindelsen til display- / programmeringsfronten PR 4501. Modulet indeholder ingen DIP-switches eller jumpere.

## SIGNATURFORKLARING



Trekant med udråbstegn: Læs manualen før installation og idriftsættelse af modulet for at undgå hændelser, der kan føre til skade på personer eller materiel.



CE-mærket er det synlige tegn på modulets overensstemmelse med EU-direktivernes krav.



Dobbelt isolation er symbolet for, at modulet overholder ekstra krav til isolation.



Ex - Modulet er godkendt efter ATEX-direktivet til brug i forbindelse med installationer i eksplosionsfarlige områder. Se installation drawings i appendiks.

## SIKKERHEDSREGLER

### DEFINITIONER

**Farlige spændinger** er defineret som områderne: 75...1500 Volt DC og 50...1000 Volt AC.

**Teknikere** er kvalificerede personer, som er uddannet eller oplært til at kunne udføre installation, betjening eller evt. fejlfinding både teknisk og sikkerhedsmæssigt forsvarligt.

**Operatører** er personer, som under normal drift med produktet skal indstille og betjene produktets trykknapper eller potentiometre, og som er gjort bekendt med indholdet af denne manual.

## **MODTAGELSE OG UDPAKNING**

Udpak modulet uden at beskadige det. Kontrollér ved modtagelsen, at modultypen svarer til den bestilte. Indpakningen bør følge modulet, indtil dette er monteret på blivende plads.

## **MILJØFORHOLD**

Undgå direkte sollys, kraftigt støv eller varme, mekaniske rystelser og stød, og udsæt ikke modulet for regn eller kraftig fugt. Om nødvendigt skal opvarmning, ud over de opgivne grænser for omgivelsestemperatur, forhindres ved hjælp af ventilation.

Modulet skal installeres i forureningsgrad 2 eller bedre.

Modulet er designet til at være sikkert mindst op til en højde af 2000 m.

## **INSTALLATION**

Modulet må kun tilsluttes af teknikere, som er bekendte med de tekniske udtryk, advarsler og instruktioner i manualen, og som vil følge disse.

Hvis der er tvivl om modulets rette håndtering, skal der rettes henvendelse til den lokale forhandler eller alternativt direkte til:

**PR electronics A/S, Lerbakken 10, 8410 Rønede,  
Danmark, tlf: +45 86 37 26 77.**

Ved tilslutning af flerkorede ledninger med farlig spænding skal ledningsenderne forsynes med ledningstykker.

Beskrivelse af indgang / udgang og forsyningsforbindelser findes på blokdiagrammet og sideskiltet.

Modulet er forsynet med skrueterminaler og skal forsynes fra en dobbeltisoleret/forstærket isoleret spændingsforsyning. En afbryder placeres let tilgængeligt og tæt ved modulet. Afbryderen skal mærkes således, at der ikke er tvivl om, at den afbryder spændingen til modulet.

Ved installation på Power Rail 9400 bliver forsyningsspændingen leveret af Power Control Unit type 9410.

Produktionsår fremgår af de to første cifre i serienummeret.

## **KALIBRERING OG JUSTERING**

Under kalibrering og justering skal måling og tilslutning af eksterne spændinger udføres i henhold til denne manual, og teknikeren skal benytte sikkerhedsmæssigt korrekte værktøjer og instrumenter.

## **BETJENING UNDER NORMAL DRIFT**

Operatører må kun indstille eller betjene modulerne, når disse er fast installeret på forsvarlig måde i tavler el. lignende, så betjeningen ikke medfører fare for liv eller materiel. Dvs., at der ikke er berøringsfare, og at modulet er placeret, så det er let at betjene.

## **RENGØRING**

Modulet må, i spændingsløs tilstand, rengøres med en klud let fugtet med destilleret vand.

## **ANSVAR**

I det omfang instruktionerne i denne manual ikke er nøje overholdt, vil kunden ikke kunne rette noget krav, som ellers måtte eksistere i henhold til den indgåede salgsaftale, mod PR electronics A/S.

## **AFMONTERING AF SYSTEM 9000**

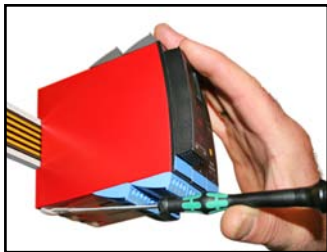

### **Billede 1:**

Modulet frigøres fra power railen ved at løfte i den nederste lås.

# EF-OVERENSSTEMMELSESERKLÆRING

Som producent erklærer

**PR electronics A/S**  
**Lerbakken 10**  
**DK-8410 Rønde**

hermed at følgende produkt:

**Type: 9203**  
**Navn: Ventil- / alarmdriver**

er i overensstemmelse med følgende direktiver og standarder:

EMC-direktivet 2004/108/EF og senere tilføjelser

**EN 61326-1 : 2006**

For specifikation af det acceptable EMC-niveau henvises til modules elektriske specifikationer.

Lavspændingsdirektivet 2006/95/EF og senere tilføjelser

**EN 61010-1 : 2001**

ATEX-direktivet 94/9/EF og senere tilføjelser

**EN 61241-0:2006, EN 61241-11:2006, EN 60079-0:2006,**  
**EN 60079-11:2007, EN 60079-15:2005, EN 60079-26:2007**  
**ATEX-certifikat: KEMA 07ATEX0147 X**

Bemyndiget organ:

**KEMA Quality B.V. (0344)**  
**Utrechtseweg 310, 6812 AR Arnhem**  
**P.O. Box 5185, 6802 ED Arnhem**  
**The Netherlands**

Rønde, 13. januar 2010



Kim Rasmussen  
Producentens underskrift

# VENTIL- / ALARMDRIVER

## 9203

- *Universel Ex-driver for ventiler, akustiske alarmer og lysdioder*
- *Udvidet autodiagnosticering*
- *1 eller 2 kanaler*
- *Kan forsynes separat eller installeres på power rail, PR type 9400*
- *SIL 2-certificeret via Full Assessment*

### Avancerede features

- Universel Ex-driver til styring af ventiler mm. med forskellige Ex-data vha. 3 indbyggede Ex-barrierer.
- To hardwareversioner giver mulighed for valg af Low (35 mA) eller High (60 mA) strømudgang.
- Opsætning og monitorering via aftagelig displayfront (PR 4501).
- Valg af direkte eller indirekte funktion for hver kanal via PR 4501 og mulighed for at reducere udgangsstrømmen til Ex-området efter behov.
- Mulighed for monitorering af udgangsstrømmen til Ex-område via PR 4501.
- Mulighed for redundant forsyning via power rail og/eller separat forsyning.

### Anvendelse

- 9203 kan monteres i sikkert område samt i zone 2 / division 2 og sende signaler til zone 0, 1, 2, 20, 21 og 22 / Class I/II/III, Div. 1, Gr. A-G.
- Ex-driver til styring af ON / OFF ventiler, akustiske alarmer og lysdioder placeret i eksplosionsfarligt område.
- 9203 styres af et NPN-/PNP-signal eller et kontaktsignal.
- Overvågning af interne fejlsituationer via det individuelle statusrelæ og / eller kollektivt elektronisk signal via power rail.
- 9203 er konstrueret, udviklet og certificeret til brug i SIL 2 installationer iht. kravene i IEC 61508.

### Teknisk karakteristik

- 1 grøn og 2 gule/røde LEDs i front indikerer normal drift og funktionsfejl.
- 2,6 kVAC galvanisk isolation mellem indgang, udgang og forsyning.

# APPLIKATIONER

## Udgangssignaler:

Kanal 1

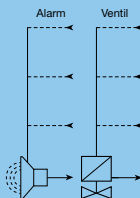

Kanal 2

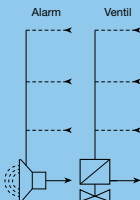

**Zone 0, 1, 2,  
20, 21, 22 /  
Cl. I/II/III, div. 1  
gr. A-G**

## Indgangssignaler:

Kanal 2

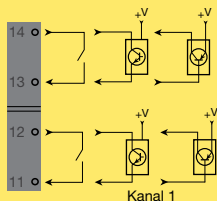

Kanal 1

Power rail

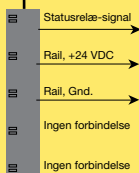

## Forsyningsspændinger:

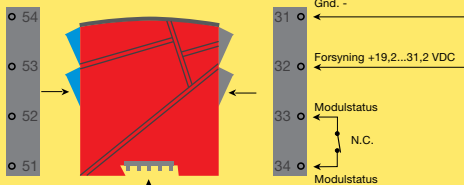

**Zone 2 / Cl. 1, div. 2, gr. A-D eller sikkert område**

# PR 4501 DISPLAY- / PROGRAMMERINGSFRONT



## Funktionalitet

Den enkle menustruktur og de forklarende hjælpetekster leder dig automatisk gennem opsætningen og gør produktet meget enkelt at anvende. Se beskrivelse af funktioner og opsætningsmuligheder under afsnittet "Programmering / betjening af trykknapper".

## Anvendelse

- Kommunikationsinterface til ændring af driftsparametre i 9203.
- Som fastmonteret display til visualisering af procesdata og status.

## Teknisk karakteristik:

- Fire liniers LCD-display, linie 1 (5,57 mm høj) viser hver kanals status (OK eller fejl). Linie 2 (3,33 mm høj) viser kanal 1's udgang (ON / OFF), linie 3 (3,33 mm høj) viser kanal 2's udgang (ON / OFF) og linie 4 viser, om modulet er SIL-låst. Statisk prik = SIL-låst og blinkende prik = ikke SIL-låst. Linie 4 viser også, om udgangen er aktiv.
- For at undgå uautoriseret brug kan konfigurationen beskyttes med et password.

## Montage / installation

- Klikkes på fronten af 9203.

## Bestillingsskema : 9203B



Type	Ex-barriere [Ex ia]	Kanaler
9203B	Low current . . . : 1	Enkelt . . . : A Dobbelt. . . : B
	High current . . . : 2	Enkelt . . . : A

**4501 = Display- / programmeringsfront**

**9400 = Power rail**

### Elektriske specifikationer

Specifikationsområde..... -20...+60°C

Lagringstemperatur..... -20...+85°C

### Fælles specifikationer:

Forsyningsspænding..... 19,2...31,2 VDC

Max. forbrug..... ≤ 3,5 W (2 kanaler)

Sikring ..... 1,25 A T / 250 VAC

Isolationsspændinger, test / drift

Indgange / udgange / forsyning..... 2,6 kVAC / 250 VAC forstærket

Udgang 1 til udgang 2 ..... 1,5 kVAC / 150 VAC forstærket

Statusrelæ til forsyning ..... 1,5 kVAC / 150 VAC forstærket

Kommunikationsinterface..... Programmeringsfront 4501

EMC-immunitetspåvirkning.....	< ±0,5% af span
-------------------------------	-----------------

Udvidet EMC-immunitet:	
------------------------	--

NAMUR NE 21, A kriterium, gniststøj.....	< ±1% af span
--	---------------

Kalibreringstemperatur..... 20...28°C

Ledningskvadrat (min. / max.)..... 0,13...2,08 mm<sup>2</sup> / AWG 26...14  
flerkoret ledning

Klemskruetilsætningsmoment..... 0,5 Nm

Relativ luftfugtighed ..... < 95% RH (ikke kond.)

Mål, uden displayfront (HxBxD) ..... 109 x 23,5 x 104 mm

Mål, med displayfront (HxBxD) ..... 109 x 23,5 x 116 mm

Kapslingsklasse..... IP20

Vægt..... 170 g / 185 g med 4501

**NPN og mekanisk kontakt:**

Trig-niveau LOW.....	≤ 2,0 VDC
Trig-niveau HIGH.....	≥ 4,0 VDC
Max. ekstern spænding .....	28 VDC
Indgangsimpedans.....	3,50 kΩ

**PNP:**

Trig-niveau LOW.....	≤ 8,0 VDC
Trig-niveau HIGH.....	≥ 10,0 VDC
Max. ekstern spænding .....	28 VDC
Indgangsimpedans.....	3,50 kΩ

**Speciel PNP trig-indgang:**

Hvis indgangssignalet kommer fra et apparat, hvor udgangen er forbundet som en åben kollektor med pull-up modstand, skal en diode forbindes i serie med indgangssignalet. Se tilslutningstegninger på side 14 for detaljer.

**Udgange:**

Udgangsripple..... < 40 mV RMS

**Ex-data:**

	9203B1A / 9203B1B								
	Klemme 41-42 / 51-52			Klemme 41-43 / 51-53			Klemme 41-44 / 51-54		
U <sub>o</sub>	28 V			28 V			28 V		
I <sub>o</sub>	93 mA			100 mA			110 mA		
P <sub>o</sub>	0,65 W			0,70 W			0,77 W		
Vudgang ubelastet	Min. 24 V			Min. 24 V			Min. 24 V		
Vudgang belastet	Min. 12,5 V			Min. 13,5 V			Min. 14,5 V		
I <sub>udg. max</sub>	35 mA			35 mA			35 mA		
	IIC	IIB	IIA	IIC	IIB	IIA	IIC	IIB	IIA
Co	80 nF	640 nF	2,1 μF	80 nF	640 nF	2,1 μF	80 nF	640 nF	2,1 μF
Lo	4,2 mH	16,8 mH	32,6 mH	3,5 mH	14,2 mH	27,6 mH	2,9 mH	11,8 mH	22,8 mH
Lo/Ro	54 μH/Ω	218 μH/Ω	436 μH/Ω	50 μH/Ω	201 μH/Ω	402 μH/Ω	46 μH/Ω	184 μH/Ω	369 μH/Ω

Uo	9203B2A								
	Klemme 41-42			Klemme 41-43			Klemme 41-44		
	28 V	28 V			28 V			28 V	
Io	115 mA			125 mA			135 mA		
Po	0,81 W			0,88 W			0,95 W		
Vudgang ubelastet	Min. 24 V			Min. 24 V			Min. 24 V		
Vudgang belastet	Min. 11,5 V		Min. 9 V	Min. 12,5 V		Min. 10 V	Min. 13,5 V		Min. 11 V
Iudg. max	50 mA		60 mA	50 mA		60 mA	50 mA		60 mA
	IIC	IIB	IIA	IIC	IIB	IIA	IIC	IIB	IIA
Co	80 nF	640 nF	2,1 µF		640 nF	2,1 µF		640 nF	2,1 µF
Lo	2,69 mH	10,8 mH	20,8 mH		9,1 mH	17,6 mH		7,8 mH	15,1 mH
Lo/Ro	44 µH/Ω	176 µH/Ω	353 µH/Ω		163 µH/Ω	327 µH/Ω		150 µH/Ω	301 µH/Ω

### Relæudgang:

Statusrelæ i sikkert område:

Max. spænding ..... 125 VAC / 110 VDC  
 Max. strøm ..... 0,5 A AC / 0,3 A DC  
 Max. effekt..... 62,5 VA / 32 W

**Marinegodkendelse:**

Det Norske Veritas, Ships &amp; Offshore ..... Ansøgt

**GOST R godkendelse:**

VNIIFTRI, Cert. No..... Ansøgt

**SIL-certificering:**

exida, Cert. No. .... xxxxxx

**Overholdte myndighedskrav:****Standard:**

EMC 2004/108/EF ..... EN 61326-1

LVD 2006/95/EF ..... EN 61010-1

ATEX 94/9/EF ..... EN 60079-0, -11, -15, -26  
og EN 61241-0, -11IECEx..... IEC 60079-0, -11, -15 og -26  
IEC 61241-0 og -11

c FM us ..... FM 3600, 3611, 3810

CSA E60079-0, -15

CSA 22.2 -25, -142, -213

ANSI/ISA-12.00.01 / 12.12.02

UL, Standard for Safety ..... UL 61010-1

SIL ..... IEC 61508

## Hardware- / softwarefejl

Visning ved hardwarefejl		
Fejlsøgning	Visning	Årsag
Test af kommunikation mellem 4501 / 9203	NO.CO	Fejl i stikforbindelse
EEProm-fejl - check konfiguration	FL.ER	Konfigurationsfejl eller crc-mismatch, recovery-konfiguration er indlæst
Hardwarefejl	DE.ER	Ugyldig recovery-konfiguration i modulet
Hardwarefejl	FC.ER	Ugyldig kode-checksum i 4501
EEProm-fejl - check konfiguration	CO.ER	Ugyldig konfiguration (CRC eller data)
Hardwarefejl	CA.ER	Fejl i fabrikskalibrering
Hardwarefejl	HW.ER	HW-setup - konfigurations-mismatch
Hardwarefejl	OC.ER	Kommunikationsfejl i primær processorkontrol
Hardwarefejl	MS.ER	Primær intern forsyning uden for grænser
Hardwarefejl	MI.ER	Fejl i primær initialiserings-selvtest
Hardwarefejl	MC.ER	Fejl i primær flash eller ram selvtest

! Alle fejlvisninger i display blinker 1 gang pr. sekund samt suppleres med tilhørende hjælpe tekst.

Fejl, som har indflydelse på begge kanaler, vises som kanal 1 fejl - og kanal 2's linie er blank.

Hardwarefejl kan resettes på to måder. Man kan steppe gennem menuerne, f.eks. hvis den anden kanal skal køre videre, eller slukke og tænde for modulet.

# TILSLUTNINGER

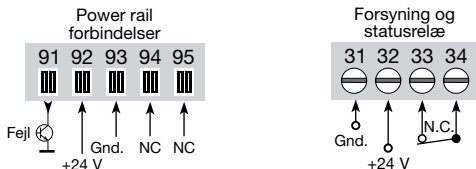

NC = Ingen forbindelse

## Indgang:

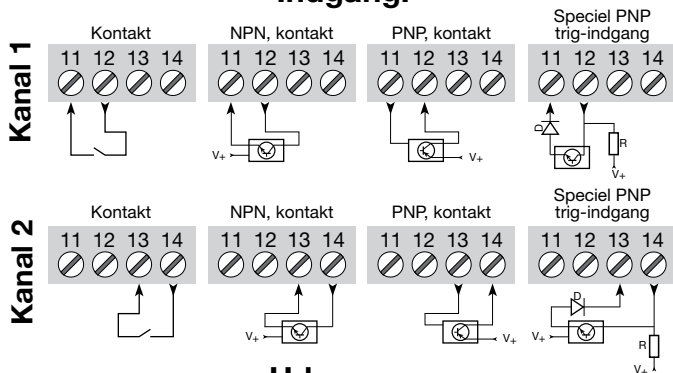

## Udgange:

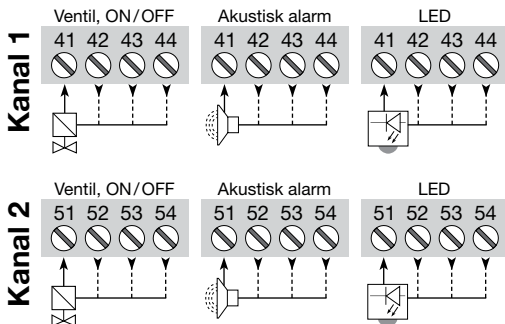

# BLOKDIAGRAM

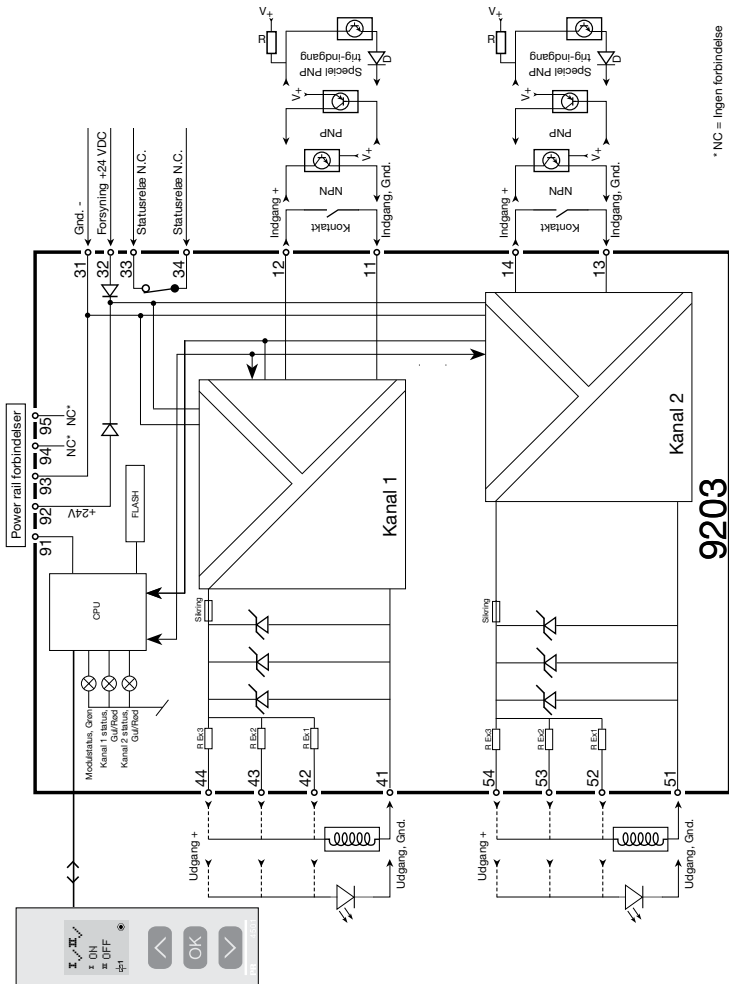

\* NC = Ingen forbindelse

## Visning af signalfejl uden displayfront

Liste over LED- og fejlsignalvisninger					
Status	Grøn LED	Kanal 1: Gul / Rød	Kanal 2: Gul / Rød	Statusrelæ, N.C.	Power rail signalstatus
Modul OK	Blinker			Trukket	OFF
Ingen forsyning	OFF	OFF	OFF	Sluppet	ON
Modul defekt	OFF	Rød	Rød	Sluppet	ON
Kanal 1, udgang ON	Blinker	Gul		Trukket	OFF
Kanal 1, udgang OFF	Blinker	OFF		Trukket	OFF
Kanal 2, udgang ON	Blinker		Gul	Trukket	OFF
Kanal 2, udgang OFF	Blinker		OFF	Trukket	OFF

## PROGRAMMERING / BETJENING AF TRYKKNAPPER

Dokumentation til rutediagram

### Generelt

Når du skal konfigurere 9203, bliver du guidet igennem samtlige parametre og kan vælge netop de indstillinger, der passer til applikationen. Til hver menu findes en rullende hjælpetekst, som vises i displaylinie 3.

Konfigurationen udføres ved hjælp af de 3 taster:

- ⬆ forøger talværdien eller vælger næste parameter
- ⬇ formindsker talværdien eller vælger forrige parameter
- Ⓚ accepterer valget og går til næste menu

Når konfigurationen er gennemført, returneres til normaltilstand 1.0.

Tryk og hold Ⓚ tasten nede for at gå til forrige menu eller normaltilstand (1.0) uden at gemme de ændrede tal eller parametre.

Hvis ingen taster har været aktiveret i 1 minut, returnerer displayet til normaltilstand (1.0) uden at gemme de ændrede tal eller parametre.

## Uddybende forklaringer

**Passwordbeskyttelse:** Programmeringsadgang kan forhindres ved indkodning af et password. Passwordet gemmes i modulet, så sikkerheden mod uønskede ændringer er så høj som muligt. Default password 2008 giver adgang til alle programmeringsmenuer.

## Signal- og modulfejlsinformation via displayfront 4501

Displayfronten 4501 kan konfigureres til at vise udgangsstatus, udgangsstrøm eller TAG.-nr. for begge kanaler. Ved hardwarefejl vises en forklarende hjælpetekst i displayet.

## Avancerede funktioner

Enheden giver adgang til en række avancerede funktioner, der nås ved at svare "yes" til punktet "adv.set".

**Display setup:** Her kan man justere kontrast og baggrundsbelysning. Opsætning af TAG-nummer med 5 alfanumeriske karakterer. Valg af funktionsvisning i linie 2 og 3 på displayet; der vælges mellem visning af udgangsstatus, udgangsstrøm og TAG-nr. Vælges "ALT" skifter displayet mellem de forskellige visningsmuligheder.

**Password:** Her kan vælges et password mellem 0000 og 9999 til beskyttelse mod uautoriserede ændringer. Enheden leveres default uden password.

**Sprog:** Der kan i menuen "LANG" vælges mellem 7 forskellige sprogvarianter af hjælpetekster, der fremkommer i menuen. Der kan vælges mellem UK, DE, FR, IT, ES, SE og DK.

**Safety Integrity Level (SIL):** Se Safety Manual (engelsk) for yderligere information.



## RUTEDIAGRAM

Hvis ingen taster har været aktiveret i 1 minut, returnerer displayet til normalttilstanden 1.0 uden at gemme eventuelle konfigurationsændringer.

- ⊗ Forøgelse af værdi / vælg næste parameter
- ⊖ Formindskelse af værdi / vælg forrige parameter
- ⊗ Accepter valget og gå til næste menu
- Holdt ⊗ går til forrige menu / returnerer til 1.0 uden at gemme

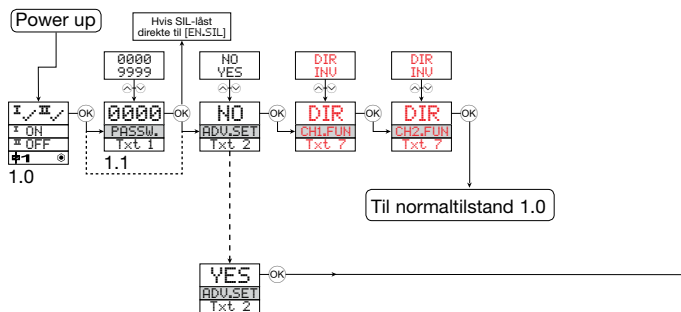

1.0 = Normaltilstand

Linie 1 viser status for kanal 1 og kanal 2.

Linie 2 viser udgangsstatus, udgangsstrøm eller TAG.-nr. for kanal 1.

Linie 3 viser udgangsstatus, udgangsstrøm eller TAG.-nr. for kanal 2.

Linie 4 indikerer om modulet er SIL-låst.

1.1 = Kun hvis beskyttet med password

1.2 = Kun hvis password er valgt.

Linie 1 symboler:

⊗ = OK. Blinkende ⊗ = fejl.

Linie 2 og 3 symboler:

⊗ ON = kanal 1 ON

⊗ OFF = kanal 2 OFF.

Linie 4 symboler:

Statisk prik = SIL-låst.

Blinkende prik = ikke SIL-låst.

⊕ = udgangen er aktiv.

**Rød tekst** viser safety parametre i en SIL-konfiguration. Se Safety Manual for yderligere information.



## RULLENDE HJÆLPETEKSTER I DISPLAYLINIE 3

- [01] Angiv korrekt password
- [02] Gå til avanceret opsætningsmenu?
- [06] Gå til valg af sprog
  - Gå til password-indstilling
  - Gå til displayopsætning
  - Gå til valg af SIL-låsning
- [07] Vælg direkte signalbehandling
  - Vælg inverteret signalbehandling
- [09] Juster LCD-kontrast
- [10] Juster LCD-baggrundsbelysning
- [11] Angiv et 5-karakters TAG-nr.
- [12] Udgangsstatus vises i display
  - Udgangsbelastning vises i display
  - TAG-nr. vises i display
  - Skiftende værdier vises i display
- [13] Konfigurationens SIL-status (åben / låst)
- [14] Vælg at SIL-låse konfigurationen
- [15] Aktiver passwordbeskyttelse?
- [16] Angiv nyt password
- [17] Vælg sprog
- [20] Ingen kommunikation - kontroller stikforbindelser
- [21] Fejl i EEPROM - kontroller konfiguration
- [22] Hardware-fejl

# SOLENOID / ALARM DRIVER

9203

## CONTENTS

Warning .....	22
Symbol identification.....	22
Safety instructions.....	22
How to demount system 9000.....	24
EC declaration of conformity .....	25
Advanced features .....	26
Application .....	26
Technical characteristics .....	26
Applications.....	27
PR 4501 Display / programming front .....	28
Order: 9203B.....	29
Electrical specifications.....	29
Visualisation in 4501 of hardware / software error .....	33
Connections .....	34
Block diagram .....	35
Signal error indications without display front.....	36
Configuration / operating the function keys .....	36
Routing diagram.....	38
Routing diagram, Advanced settings (ADV.SET).....	39
Scrolling help texts in display line 3.....	40
Appendix .....	81
IECEx Installation Drawing .....	82
ATEX Installation Drawings, UK, FR, DE, DK.....	84
FM Installation Drawing.....	92
Safety Manual .....	94



## WARNING

The following operations should only be carried out on a disconnected device and under ESD-safe conditions:

- General mounting, connection and disconnection of wires.
- Troubleshooting the device.

**Repair of the device and replacement of circuit breakers must be done by PR electronics A/S only.**



## WARNING

Do not open the front plate of the device as this will cause damage to the connector for the display / programming front PR 4501. This device contains no DIP-switches or jumpers.

## SYMBOL IDENTIFICATION



**Triangle with an exclamation mark:** Read the manual before installation and commissioning of the device in order to avoid incidents that could lead to personal injury or mechanical damage.



**The CE mark** proves the compliance of the device with the essential requirements of the directives.



**The double insulation symbol** shows that the device is protected by double or reinforced insulation.



**Ex devices** have been approved according to the ATEX directive for use in connection with installations in explosive areas. See installation drawings in appendix.

## SAFETY INSTRUCTIONS

### DEFINITIONS

**Hazardous voltages** have been defined as the ranges: 75...1500 Volt DC, and 50...1000 Volt AC.

**Technicians** are qualified persons educated or trained to mount, operate, and also troubleshoot technically correct and in accordance with safety regulations.

**Operators**, being familiar with the contents of this manual, adjust and operate the knobs or potentiometers during normal operation.

## **RECEIPT AND UNPACKING**

Unpack the device without damaging it and check whether the device type corresponds to the one ordered. The packing should always follow the device until this has been permanently mounted.

## **ENVIRONMENT**

Avoid direct sunlight, dust, high temperatures, mechanical vibrations and shock, as well as rain and heavy moisture. If necessary, heating in excess of the stated limits for ambient temperatures should be avoided by way of ventilation.

The device must be installed in pollution degree 2 or better.

The device is designed to be safe at least under an altitude up to 2 000 m.

## **MOUNTING**

Only technicians who are familiar with the technical terms, warnings, and instructions in the manual and who are able to follow these should connect the device.

Should there be any doubt as to the correct handling of the device, please contact your local distributor or, alternatively,

**PR electronics A/S, Lerbakken 10,  
8410 Rønde, Denmark tel. +45 86 37 26 77.**

The use of stranded wires is not permitted for mains wiring except when wires are fitted with cable ends.

Descriptions of input / output and supply connections are shown in the block diagram and on the side label.

The device is provided with field wiring terminals and shall be supplied from a Power Supply having double / reinforced insulation. A power switch shall be easily accessible and close to the device. The power switch shall be marked as the disconnecting unit for the device.

For installation on Power Rail 9400 the power is supplied by Power Control Unit 9410.

Year of manufacture can be taken from the first two digits in the serial number.

## **CALIBRATION AND ADJUSTMENT**

During calibration and adjustment, the measuring and connection of external voltages must be carried out according to the specifications of this manual. The technician must use tools and instruments that are safe to use.

## **NORMAL OPERATION**

Operators are only allowed to adjust and operate devices that are safely fixed in panels, etc., thus avoiding the danger of personal injury and damage. This means there is no electrical shock hazard, and the device is easily accessible.

## **CLEANING**

When disconnected, the device may be cleaned with a cloth moistened with distilled water.

## **LIABILITY**

To the extent that the instructions in this manual are not strictly observed, the customer cannot advance a demand against PR electronics A/S that would otherwise exist according to the concluded sales agreement.

## **HOW TO DEMOUNT SYSTEM 9000**

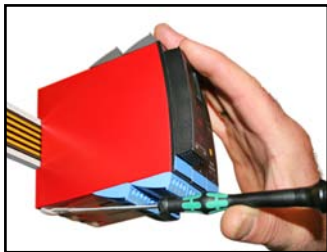

**Picture 1:**

By lifting the bottom lock, the device is detached from the DIN rail.

# EC DECLARATION OF CONFORMITY

As manufacturer

**PR electronics A/S**  
**Lerbakken 10**  
**DK-8410 Rønde**

hereby declares that the following product:

**Type: 9203**  
**Name: Solenoid / alarm driver**

is in conformity with the following directives and standards:

The EMC Directive 2004/108/EC and later amendments

**EN 61326-1 : 2006**

For specification of the acceptable EMC performance level, refer to the electrical specifications for the device.

The Low Voltage Directive 2006/95/EC and later amendments

**EN 61010-1 : 2001**

The ATEX Directive 94/9/EC and later amendments

**EN 61241-0:2006, EN 61241-11:2006, EN 60079-0:2006,**  
**EN 60079-11:2007, EN 60079-15:2005, EN 60079-26:2007**  
**ATEX certificate: KEMA 07ATEX0147 X**

Notified body

**KEMA Quality B.V. (0344)**  
**Utrechtseweg 310, 6812 AR Arnhem**  
**P.O. Box 5185, 6802 ED Arnhem**  
**The Netherlands**

Rønde, 13 January 2010



Kim Rasmussen  
Manufacturer's signature

# SOLENOID / ALARM DRIVER

## 9203

- *Universal Ex driver for solenoids, acoustic alarms and LEDs*
- *Extended self-diagnostics*
- *1 or 2 channels*
- *Can be supplied separately or installed on power rail, PR 9400*
- *SIL 2-certified via Full Assessment*

### **Advanced features**

- Universal Ex driver for the control of solenoids etc. with various Ex data by way of three built-in Ex barriers.
- Two hardware versions make it possible to choose either Low (35 mA) or High (60 mA) current output.
- Configuration and monitoring by way of detachable display front (PR 4501).
- Selection of direct or inverted function for each channel via PR 4501 and the possibility of reducing the output current to the hazardous area to suit the application.
- Optional monitoring of the output current to the hazardous area by way of PR 4501.
- Optional redundant supply via power rail and/or separate supply.

### **Application**

- The device can be mounted in the safe area and in zone 2 / div. 2 and transmit signals to zone 0, 1, 2, 20, 21 and 22.
- Ex driver for the control of ON / OFF solenoids, acoustic alarms and LEDs mounted in the hazardous area.
- The 9203 is controlled by an NPN/PNP signal or a switch signal.
- Monitoring of internal error events via the individual status relay and/or a collective electronic signal via the power rail.
- The 9203 has been designed, developed and certified for use in SIL 2 applications according to the requirements of IEC 61508.

### **Technical characteristics**

- 1 green and 2 yellow/red front LEDs indicate operation status and malfunction.
- 2.6 kVAC galvanic isolation between input, output and supply.

# APPLICATIONS

## Output signals:

Channel 1

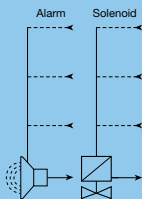

Channel 2

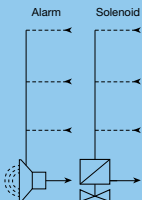

**Zone 0, 1, 2,  
20, 21, 22 /  
Cl. I/II/III, div. 1  
gr. A-G**

## Input signals:

Channel 2

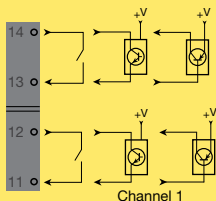

Power rail

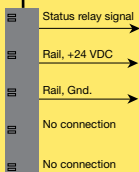

## Power connection:

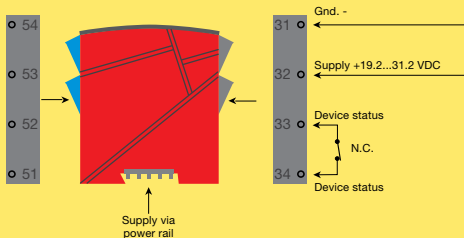

**Zone 2 / Cl. 1, div. 2, gr. A-D or safe area**

## PR 4501 DISPLAY / PROGRAMMING FRONT



### Functionality

The simple and easily understandable menu structure and the explanatory help texts guide you effortlessly and automatically through the configuration steps, thus making the product very easy to use. Functions and configuration options are described in the section "Configuration / operating the function keys".

### Application

- Communications interface for modification of operational parameters in 9203.
- When mounted in the process, the display shows process values and device status.

### Technical characteristics

- LCD display with 4 lines; Line 1 (H=5.57 mm) shows status for each channel (OK or error). Line 2 (H=3.33 mm) shows output for channel 1 (ON / OFF), line 3 (H=3.33 mm) shows output for channel 2 (ON / OFF), and line 4 shows whether the device is SIL-locked. Static dot = SIL-locked and flashing dot = not SIL-locked. Line 4 also indicates if the output is active.
- In order to protect the configuration against unauthorised changes, access to the menus can be blocked by a password.

### Mounting / installation

- Click 4501 onto the front of 9203.

Order: 9203B

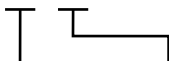

Type	Ex barrier [Ex ia]	Channels
9203B	Low current . . . : 1	Single . . . : A Double . . . : B
	High current . . . : 2	Single . . . : A

4501 = Display / programming front

9400 = Power rail

### Electrical specifications

Specifications range..... -20...+60°C

Storage temperature ..... -20...+85°C

#### Common specifications:

Supply voltage..... 19.2...31.2 VDC

Max. consumption..... ≤ 3.5 W (2 channels)

Fuse..... 1.25 A SB / 250 VAC

Isolation voltage, test / operation:

Input / output / supply ..... 2.6 kVAC / 250 VAC

Output 1 to output 2 ..... 1.5 kVAC / 150 VAC reinforced

Status relay to supply ..... 1.5 kVAC / 150 VAC reinforced

Communications interface ..... Programming front 4501

Calibration temperature..... 20...28°C

EMC immunity influence ..... < ±0.5% of span

Extended EMC immunity:

NAMUR NE 21, A criterion, burst ..... < ±1% of span

Wire size (min....max.) ..... 0.13...2.08 mm<sup>2</sup> / AWG 26...14  
stranded wire

Screw terminal torque ..... 0.5 Nm

Relative humidity ..... < 95% RH (non-cond.)

Dimensions, without display front (HxWxD). 109 x 23.5 x 104 mm

Dimensions, with display front (HxWxD)..... 109 x 23.5 x 116 mm

Protection degree..... IP20

Weight ..... 170 g / 185 g with 4501

**NPN and mechanical switch:**

Trig level LOW .....	≤ 2.0 VDC
Trig level HIGH .....	≥ 4.0 VDC
Max. external voltage.....	28 VDC
Input impedance .....	3.50 kΩ

**PNP:**

Trig level LOW .....	≤ 8.0 VDC
Trig level HIGH .....	≥ 10.0 VDC
Max. external voltage.....	28 VDC
Input impedance .....	3.50 kΩ

**Special PNP trig input:**

If the input signal comes from a device where the output is connected as an open collector with pull up resistor, a diode must be connected in series with the input signal. See connections drawing at page 34 for further details.

**Outputs:**

Output ripple ..... < 40 mV RMS

**Ex / I.S. data:**

	9203B1A / 9203B1B								
	Terminal 41-42 / 51-52			Terminal 41-43 / 51-53			Terminal 41-44 / 51-54		
U <sub>o</sub>	28 V			28 V			28 V		
I <sub>o</sub>	93 mA			100 mA			110 mA		
P <sub>o</sub>	0.65 W			0.70 W			0.77 W		
V <sub>out.</sub> no load	Min. 24 V			Min. 24 V			Min. 24 V		
V <sub>out.</sub> with load	Min. 12.5 V			Min. 13.5 V			Min. 14.5 V		
I <sub>out. max</sub>	35 mA			35 mA			35 mA		
	IIC	IIB	IIA	IIC	IIB	IIA	IIC	IIB	IIA
C <sub>o</sub>	80 nF	640 nF	2.1 μF	80 nF	640 nF	2.1 μF	80 nF	640 nF	2.1 μF
L <sub>o</sub>	4.2 mH	16.8 mH	32.6 mH	3.5 mH	14.2 mH	27.6 mH	2.9 mH	11.8 mH	22.8 mH
L <sub>o</sub> /R <sub>o</sub>	54 μH/Ω	218 μH/Ω	436 μH/Ω	50 μH/Ω	201 μH/Ω	402 μH/Ω	46 μH/Ω	184 μH/Ω	369 μH/Ω

Uo	9203B2A								
	Terminal 41-42			Terminal 41-43			Terminal 41-44		
	28 V	28 V			28 V			28 V	
Io	115 mA			125 mA			135 mA		
Po	0.81 W			0.88 W			0.95 W		
Vout. no load	Min. 24 V			Min. 24 V			Min. 24 V		
Vout. with load	Min. 11.5 V	Min. 9 V		Min. 12.5 V	Min. 10 V		Min. 13.5 V	Min. 11 V	
Iout. max	50 mA	60 mA		50 mA	60 mA		50 mA	60 mA	
	IIC	IIB	IIA	IIC	IIB	IIA	IIC	IIB	IIA
Co	80 nF	640 nF	2.1 μF		640 nF	2.1 μF		640 nF	2.1 μF
Lo	2.69 mH	10.8 mH	20.8 mH		9.1 mH	17.6 mH		7.8 mH	15.1 mH
Lo/Ro	44 μH/Ω	176 μH/Ω	353 μH/Ω		163 μH/Ω	327 μH/Ω		150 μH/Ω	301 μH/Ω

### Relay output:

Status relay in safe area:

Max. voltage..... 125 VAC / 110 VDC  
 Max. current..... 0.5 A AC / 0.3 A DC  
 Max. power ..... 62.5 VA / 32 W

**Marine approval:**

Det Norske Veritas, Ships & Offshore ..... Pending

**GOST R approval:**

VNIIFTRI, Cert No..... Pending

**SIL certification:**

exida, Cert No. .... XXXXXXXX

**Observed authority requirements:****Standard:**

EMC 2004/108/EC ..... EN 61326-1

LVD 2006/95/EC ..... EN 61010-1

ATEX 94/9/EC ..... EN 60079-0, -11, -15, -26  
and EN 61241-0, -11

IECEX ..... IEC 60079-0, -11, -15 and -26  
IEC 61241-0 and -11

c FM us ..... FM 3600, 3611, 3810

CSA E60079-0, -15

CSA 22.2 -25, -142, -213

ANSI/ISA-12.00.01 / 12.12.02

UL, Standard for Safety ..... UL 61010-1

SIL ..... IEC 61508

## Visualisation in 4501 of hardware / software error

Readout at hardware error:		
Error search	Readout	Cause
Communications test 4501 / 9203	NO.CO	Connection error
EEProm error - check configuration	FL.ER	Configuration error or crc mismatch, recovery configuration is loaded
Hardware error	DE.ER	Invalid recovery configuration in device
Hardware error	FC.ER	Invalid code checksum in 4501
EEProm error - check configuration	CO.ER	Invalid configuration (CRC or data)
Hardware error	CA.ER	Factory calibration error
Hardware error	HW.ER	HW setup - configuration mismatch
Hardware error	OC.ER	Main output controller communication error
Hardware error	MS.ER	Main internal supply out of bounds
Hardware error	MI.ER	Main initialisation selftest failed
Hardware error	MC.ER	Main flash or ram selftest failed

! All error indications in the display flash once per second. The help text explains the error.

Errors affecting both channels are shown as error on channel 1 - and the line showing channel 2 is blank.

Hardware error can be reset in two ways. Either step through the menus (if the other channel is to stay in operation) or power cycle the device.

# CONNECTIONS

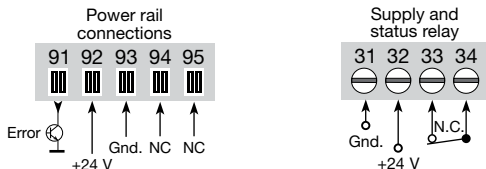

NC = No connection

## Inputs:

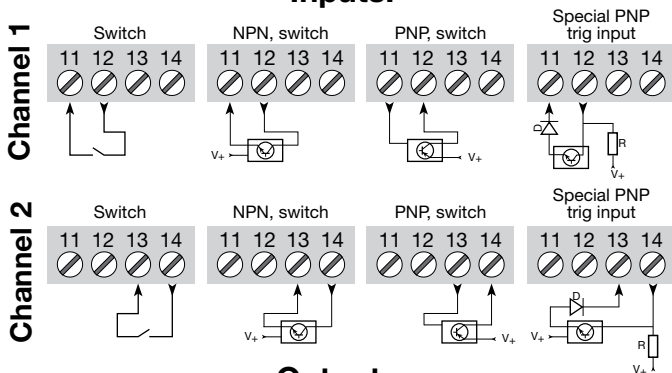

## Outputs:

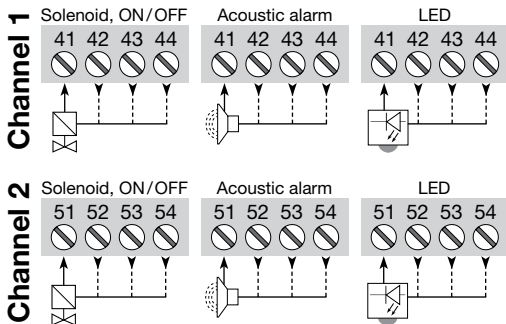

# BLOCK DIAGRAM

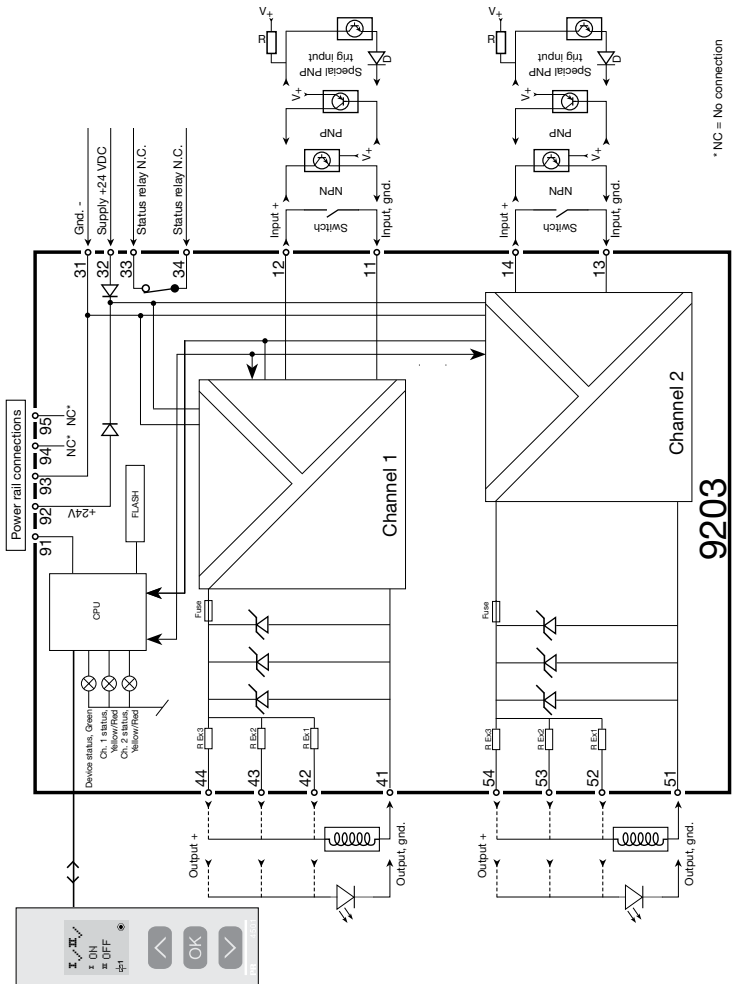

\* NC = No connection

9203

## Signal error indications without display front

LED and error signal indications					
State	Green LED	Ch 1: Yellow/Red	Ch 2: Yellow/Red	Status relay, N.C.	Power rail signal status
Device OK	Flashing			Energised	OFF
No supply	OFF	OFF	OFF	De-energised	ON
Device defective	OFF	Red	Red	De-energised	ON
Ch. 1, output ON	Flashing	Yellow		Energised	OFF
Ch. 1, output OFF	Flashing	OFF		Energised	OFF
Ch. 2, output ON	Flashing		Yellow	Energised	OFF
Ch. 2, output OFF	Flashing		OFF	Energised	OFF

## CONFIGURATION / OPERATING THE FUNCTION KEYS

Documentation for routing diagram.

### In general

When configuring the 9203, you will be guided through all parameters and you can choose the settings which fit the application. For each menu there is a scrolling help text which is automatically shown in line 3 on the display.

Configuration is carried out by use of the 3 function keys:

- ⬆ will increase the numerical value or choose the next parameter
- ⬇ will decrease the numerical value or choose the previous parameter
- ⊗ will accept the chosen value and proceed to the next menu

When configuration is completed, the display will return to the default state 1.0.

Pressing and holding ⊗ will return to the previous menu or return to the default state (1.0) without saving the changed values or parameters.

If no key is activated for 1 minute, the display will return to the default state (1.0) without saving the changed values or parameters.

## Further explanations

**Password protection:** Programming access can be blocked by assigning a password. The password is saved in the device in order to ensure a high degree of protection against unauthorised modifications to the configuration. Default password 2008 allows access to all configuration menus.

## Signal and device error information via display front 4501

The display front can be configured to show output status, output current or tag no. for both channels. In case of hardware error, a help text explaining the error will be displayed.

## Advanced functions

The unit gives access to a number of advanced functions which can be reached by answering "Yes" to the point "adv.set".

**Display setup:** Here you can adjust the brightness contrast and the backlight. Setup of TAG numbers with 5 alphanumeric. Selection of functional readout in line 2 and 3 of the display - choose between readout of output status, output current or tag no. When selecting "ALT" the readout toggles between the display options.

**Password:** Here you can choose a password between 0000 and 9999 in order to protect the device against unauthorised modifications to the configuration. The device is delivered default without password.

**Language:** In the menu "LANG" you can choose between 7 different language versions of help texts that will appear in the menu. You can choose between UK, DE, FR, IT, ES, SE and DK.

**Safety Integrity Level (SIL):** See Safety Manual for details.



## ROUTING DIAGRAM

If no key is activated for 1 minute, the display will return to the default state 1.0 without saving configuration changes.

⏪ Increase value / choose next parameter

⏩ Decrease value / choose previous parameter

⊗ Accept the chosen value and proceed to the next menu

Hold ⊗ Back to previous menu / return to menu 1.0 without saving

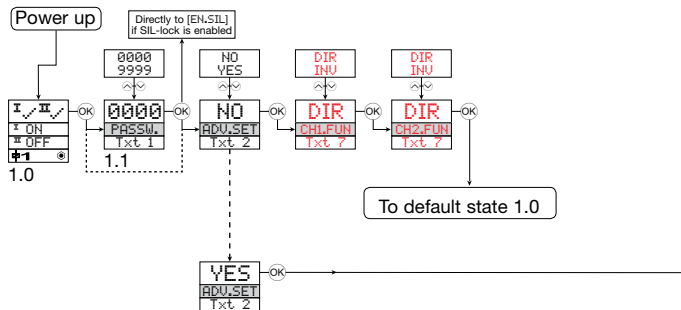

1.0 = Default state

Line 1 shows status for channel 1 and channel 2.

Line 2 shows output status for channel 1, output current or tag no.

Line 3 shows output status for channel 2, output current or tag no.

Line 4 indicates whether the device is SIL-locked.

1.1 = Only if password-protected.

1.2 = If password has been set.

Line 1 symbols:

⏪ = OK. Flashing ⏩ = error.

Line 2 and 3 symbols:

⏪ ON = channel 1 ON

⏩ OFF = channel 2 OFF.

Line 4 symbols:

Static dot = SIL-locked.

Flashing dot = Not SIL-locked.

⏪ = output is active.

Red text signifies safety

parameters in a SIL configuration. See safety manual for details



## SCROLLING HELP TEXTS IN DISPLAY LINE 3

- [01] Set correct password
- [02] Enter advanced setup?
- [06] Enter language setup  
Enter password setup  
Enter display setup  
Enter SIL setup
- [07] Select direct channel function  
Select inverted channel function
- [09] Adjust LCD contrast
- [10] Adjust LCD backlight
- [11] Write a 5-character channel tag
- [12] Show output state in display  
Show output load in display  
Show tag in display  
Alternate information shown in display
- [13] Configuration SIL status (Open / Locked)
- [14] Enable SIL configuration lock
- [15] Enable password protection?
- [16] Set new password
- [17] Select language
- [20] No communication - check connections
- [21] EEprom error - check configuration
- [22] Hardware error

# ALIMENTATION D'ÉLECTROVANNES, [Ex ia]

9203

## SOMMAIRE

Avertissement.....	42
Consignes de sécurité .....	42
Démontage du système 9000 .....	44
Déclaration de conformité CE.....	45
Options avancées.....	46
Fonctions.....	46
Caractéristiques techniques.....	46
Applications.....	47
PR 4501 indicateur / façade de programmation.....	48
Référence de commande: 9203B.....	49
Spécifications.....	49
Indications erreurs matériels / logiciels.....	53
Connexions .....	54
Schéma de principe .....	55
Indications d'erreur signal sans la façade 4501 .....	56
Configuration / opération des touches de fonctions .....	56
Diagramme de programmation .....	58
Diagramme de programmation, Reglage avance (ADV.SET).....	59
Menu déroulant en ligne 3 de l'indicateur.....	60
Appendix .....	81
IECEx Installation Drawing .....	82
ATEX Installation Drawings, UK, FR, DE, DK.....	84
FM Installation Drawing.....	92
Safety manual.....	94



## AVERTISSEMENT

Les opérations suivantes doivent être effectuées avec le module débranché et dans un environnement exempt de décharges électrostatiques (ESD) :

- Montage général, raccordement et débranchement de fils.
- Recherche de pannes sur le module.

**Seule PR electronics SARL est autorisée à réparer le module et à remplacer les fusibles.**



## AVERTISSEMENT

Ne pas ouvrir la plaque avant du module au risque d'endommager le connecteur de l'indicateur / la façade de programmation PR 4501. Ce module ne contient ni de commutateurs DIP ni de cavaliers.

## SIGNIFICATION DES SYMBOLES



**Triangle avec point d'exclamation** : Attention ! Lire ce manuel avant l'installation et la mise en service de ce module afin d'éviter des incidents pouvant causer des dommages corporels ou des dégâts mécaniques.



**Le signe CE** indique que le module est conforme aux exigences des directives.



Ce symbole indique que le module est protégé par une **isolation double** ou renforcée.



L'utilisation des modules de **type Ex** avec des installations situées dans des zones à risques d'explosions a été autorisée suivant la directive ATEX. Voir le schéma d'installation dans les annexes.

## CONSIGNES DE SECURITE

### DEFINITIONS

**Les gammes de tensions dangereuses** sont les suivantes : de 75 à 1500 Vcc et de 50 à 1000 Vca.

**Les techniciens** sont des personnes qualifiées qui sont capables de monter et de faire fonctionner un appareil, et d'y rechercher les pannes, tout en respectant les règles de sécurité.

**Les opérateurs**, connaissant le contenu de ce guide, règlent et actionnent les boutons ou les potentiomètres au cours des manipulations ordinaires.

## **RECEPTION ET DEBALLAGE**

Déballer le module sans l'endommager. Il est recommandé de conserver l'emballage du module tant que ce dernier n'est pas définitivement monté. A la réception du module, vérifiez que le type de module reçu correspond à celui que vous avez commandé.

## **ENVIRONNEMENT**

N'exposez pas votre module aux rayons directs du soleil et choisissez un endroit à l'humidité modérée et à l'abri de la poussière, des températures élevées, des chocs et des vibrations mécaniques et de la pluie. Le cas échéant, des systèmes de ventilation permettent d'éviter qu'une pièce soit chauffée au-delà des limites prescrites pour les températures ambiantes.

Ce module doit être installé en degré de pollution 2 ou meilleur.

Ce module est conçu pour fonctionner en toute sécurité sous une altitude inférieure à 2000 m.

## **MONTAGE**

Il est conseillé de réserver le raccordement du module aux techniciens qui connaissent les termes techniques, les avertissements et les instructions de ce guide et qui sont capables d'appliquer ces dernières.

Si vous avez un doute quelconque quant à la manipulation du module, veuillez contacter votre distributeur local. Vous pouvez également vous adresser à

PR electronics SARL, Zac du Chêne, Activillage, 4, allée des Sorbiers,

F-69673 Bron Cedex (tél. : (0) 472 140 607) ou à

PR electronics A/S, Lerbakken 10, DK-8410 Rønne, Danemark (tél.: +45 86 37 26 77).

Pour le raccordement électrique de l'alimentation générale, il est possible d'utiliser des fils multibrins seulement s'ils possèdent des embouts de câblage.

Les connexions des alimentations et des entrées / sorties sont décrites dans le schéma de principe et sur l'étiquette de la face latérale du module.

Les appareils sont équipés de borniers à vis et doivent être raccordés à une alimentation qui a une isolation double ou renforcée. L'interrupteur doit être à proximité du module et facile d'accès. Ce bouton doit être étiqueté avec la mention : peut couper la tension du module.

Pour une installation sur le rail d'alimentation 9400, le module sera alimenté par le contrôleur d'alimentation 9410.

L'année de production est définie par les deux premiers chiffres du numéro de série.

### **ETALONNAGE ET REGLAGE**

Lors des opérations d'étalonnage et de réglage, il convient d'effectuer les mesures et les connexions des tensions externes en respectant les spécifications mentionnées dans ce guide. Les techniciens doivent utiliser des outils et des instruments pouvant être manipulés en toute sécurité.

### **MANIPULATIONS ORDINAIRES**

Les opérateurs sont uniquement autorisés à régler et faire fonctionner des modules qui sont solidement fixés sur des platines des tableaux, ect., afin d'écartier les risques de dommages corporels. Autrement dit, il ne doit exister aucun danger d'électrocution et le module doit être facilement accessible.

### **MAINTENANCE ET ENTRETIEN**

Une fois le module hors tension, prenez un chiffon imbibé d'eau distillée pour le nettoyer.

### **LIMITATION DE RESPONSABILITE**

Dans la mesure où les instructions de ce guide ne sont pas strictement respectées par le client, ce dernier n'est pas en droit de faire une réclamation auprès de PR electronics SARL, même si cette dernière figure dans l'accord de vente conclu.

## **DEMONTAGE DU SYSTEME 9000**

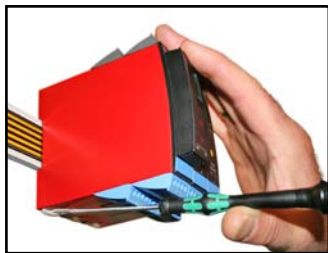

**Figure 1 :**

Débloquez le verrou inférieur pour dégager le module du rail d'alimentation.

# DECLARATION DE CONFORMITE CE

En tant que fabricant

**PR electronics A/S**  
**Lerbakken 10**  
**DK-8410 Rønde**

déclare que le produit suivant :

**Type: 9203**  
**Nom: Alimentation d'électrovannes, [Ex ia]**

correspond aux directives et normes suivantes :

La directive CEM (EMC) 2004/108/CE et les modifications subséquentes

**EN 61326-1 : 2006**

Pour une spécification du niveau de rendement acceptable CEM (EMC)  
se référer aux spécifications électriques du module.

La directive basse tension 2006/95/CE et les modifications subséquentes

**EN 61010-1 : 2001**

La directive ATEX 94/9/CE et les modifications subséquentes

**EN 61241-0:2006, EN 61241-11:2006, EN 60079-0:2006,**  
**EN 60079-11:2007, EN 60079-15:2005, EN 60079-26:2007**  
**Certificat ATEX: KEMA 07ATEX0147 X**

Organisme notifié :

**KEMA Quality B.V. (0344)**  
**Utrechtseweg 310, 6812 AR Arnhem**  
**P.O. Box 5185, 6802 ED Arnhem**  
**The Netherlands**

Rønde, le 13 janvier 2010



Kim Rasmussen  
Signature du fabricant

# ALIMENTATION D'ELECTROVANNES, [Ex ia] 9203

- Alimentation S.I. universelle pour vannes, voyants et alarmes
- Autodiagnostic avancé
- 1 ou 2 voies
- Alimentée séparément ou par le rail d'alimentation, PR type 9400
- Certifiée SIL 2 en « Evaluation Complète »

## Options avancées

- Alimentation S.I. universelle pour contrôler des électrovannes etc. avec des caractéristiques S.I. différentes à l'aide de 3 barrières S.I. incorporées.
- Deux types de modules permettent la choix entre sortie de courant basse (35 mA) ou haute (60 mA).
- Configuration et contrôle à l'aide de la façade de programmation débrochable (PR 4501).
- Sélection de la fonction directe ou inverse pour chaque voie par PR 4501 et possibilité de réduire le courant de sortie vers la zone dangereuse selon l'application.
- Surveillance facultative du courant de sortie vers la zone dangereuse par PR 4501.
- Alimentation redondante facultative par rail et / ou alimentation séparée.

## Fonctions

- Le module peut être installé dans la zone non-dangereuse et en zone 2 / div. 2 et transmettre des signaux vers zone 0, 1, 2, 20, 21 et 22 / Class I/II/III, Div. 1, Gr. A-G.
- Alimentation S.I. pour contrôler des électrovannes, alarmes sonores et voyants situés en zone dangereuse.
- Le 9203 est contrôlé par un signal NPN/PNP ou un contact sec.
- Surveillance de cas d'erreurs internes par le relais d'état individuel et / ou un signal électronique collectif par le rail d'alimentation.
- Le 9203 a été conçu, développé et certifié pour utilisation dans les applications SIL 2 en conformité avec les exigences de la CEI 61508.

## Caractéristiques techniques

- 1 DEL verte et 2 DEL jaunes / rouges en face avant indiquent un fonctionnement normal ou incorrect du module.
- Isolation galvanique de 2,6 kVca entre l'entrée, la sortie et l'alimentation.

## APPLICATIONS

Signaux de sortie :

Voie 1

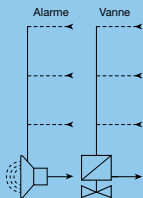

Voie 2

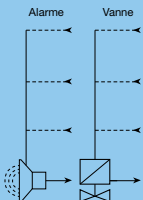

**Zone 0, 1, 2,  
20, 21, 22 /  
Cl. I/II/III, div. 1  
gr. A-G**

Signaux d'entrée :

Voie 2

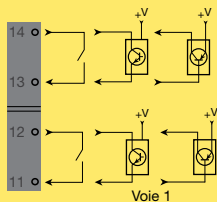

Voie 1

Rail  
d'alimentation

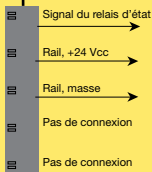

Connexion d'alimentation :

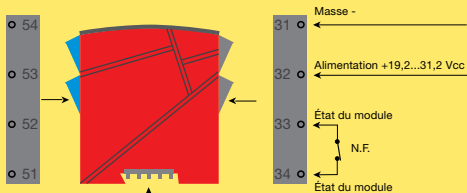

Alimentation  
par rail

**Zone 2 / Cl. 1, div. 2, gr. A-D ou zone non-dangereuse**

# PR 4501 INDICATEUR / FAÇADE DE PROGRAMMATION



## Fonctionnalité :

Le menu simple, structuré à l'aide de questions, guide automatiquement l'utilisateur par un menu déroulant et rend ainsi aisée l'utilisation du produit. Voir la description des fonctions et options de configuration dans la section « Configuration / utilisation des touches de fonction ».

## Application

- Interface de communication pour la modification des paramètres de fonctionnement du 9203.
- Quand le 4501 est monté sur le module, il affiche les valeurs du process et l'état du module.

## Caractéristiques techniques

- Affichage LCD en 4 lignes; Ligne 1 (5,57 mm de haut) affiche l'état de chaque voie (OK ou erreur). Ligne 2 (3,33 mm de haut) affiche la sortie de la voie 1 (ON / OFF), ligne 3 (3,33 mm de haut) affiche la sortie de la voie 2 (ON / OFF), et ligne 4 affiche l'état SIL (ouvert / verrouillé). Point statique = verrouillage SIL, point clignotant = aucun verrouillage SIL. Ligne 4 indique aussi quand la sortie est active.
- Afin de protéger la configuration contre les modifications non-autorisées, l'accès aux menus peut être bloqué par un mot de passe.

## Montage / installation

- Cliquer le 4501 sur la face avant du 9203.

## Référence de commande: 9203B

Type	Barrière S.I. [Ex ia]	Voies
9203B	Courant bas ... : 1	Une..... : A Deux..... : B
	Courant haut .. : 2	Une..... : A

**4501 = Indicateur / façade de programmation**

**9400 = Rail d'alimentation**

### Spécifications

#### Plages de température:

Plage d'utilisation..... -20...+60°C

Température de stockage..... -20...+85°C

#### Spécifications communes:

Tension d'alimentation ..... 19,2...31,2 Vcc

Consommation max. .... ≤ 3,5 W (2 voies)

Fusible ..... 1,25 A SB / 250 Vca

#### Tension d'isolation, test / opération:

Entrée / sortie / alimentation..... 2,6 kVca / 250 Vca renforcée

Sortie 1 à sortie 2..... 1,5 kVca / 150 Vca renforcée

Relais d'état à l'alimentation..... 1,5 kVca / 150 Vca renforcée

Interface de communication ..... Façade de programmation 4501

Immunité CEM..... < ±0,5% de l'EC

Immunité CEM améliorée:

NAMUR NE 21, critère A, burst ..... < ±1% de l'EC

Température d'étalonnage ..... 20...28°C

Taille des fils (min...max.) ..... 0,13...2,08 mm<sup>2</sup> / AWG 26...14  
fils multibrins

Pression max. avant déformation de la vis. 0,5 Nm

Humidité relative..... < 95% RH (sans cond.)

Dimensions, sans façade 4501 (HxLxP) ..... 109 x 23,5 x 104 mm

Dimensions, avec façade 4501 (HxLxP) ..... 109 x 23,5 x 116 mm

Degré de protection ..... IP20

Poids ..... 170 g / 185 g avec 4501

**NPN et contact:**

Niveau de déclenchement BAS .....	≤ 2,0 Vcc
Niveau de déclenchement HAUT.....	≥ 4,0 Vcc
Tension externe max. ....	28 Vcc
Impédance d'entrée .....	3,50 kΩ

**PNP:**

Niveau de déclenchement BAS .....	≤ 8,0 Vcc
Niveau de déclenchement HAUT.....	≥ 10,0 Vcc
Tension externe max. ....	28 Vcc
Impédance d'entrée .....	3,50 kΩ

**Entrée de déclenchement PNP spéciale:**

Si le signal d'entrée vient d'un dispositif où la sortie est connectée comme une collecteur ouvert avec résistance de pull-up, une diode doit être connectée en série avec le signal d'entrée. Voir le schéma des connexions à la page 54 pour plus d'informations.

**Sorties:**

Taux tension d'ondulation ..... < 40 mV RMS

**Caractéristiques Ex / S.I.:**

	9203B1A / 9203B1B								
	Bornes 41-42 / 51-52			Bornes 41-43 / 51-53			Bornes 41-44 / 51-54		
	Uo	Io	Po	Vsor non- chargée	Vsortie chargée	Isortie max	IIC	IIB	IIA
	28 V	93 mA	0,65 W	Min. 24 V	Min. 12,5 V	35 mA	IIC	IIB	IIA
	28 V	100 mA	0,70 W	Min. 24 V	Min. 13,5 V	35 mA	IIC	IIB	IIA
	28 V	110 mA	0,77 W	Min. 24 V	Min. 14,5 V	35 mA	IIC	IIB	IIA
							IIC	IIB	IIA
Co	80 nF	640 nF	2,1 μF	80 nF	640 nF	2,1 μF	80 nF	640 nF	2,1 μF
Lo	4,2 mH	16,8 mH	32,6 mH	3,5 mH	14,2 mH	27,6 mH	2,9 mH	11,8 mH	22,8 mH
Lo/Ro	54 μH/Ω	218 μH/Ω	436 μH/Ω	50 μH/Ω	201 μH/Ω	402 μH/Ω	46 μH/Ω	184 μH/Ω	369 μH/Ω

	9203B2A								
	Bornes 41-42			Bornes 41-43			Bornes 41-44		
	Uo	28 V			28 V			28 V	
Io	115 mA			125 mA			135 mA		
Po	0,81 W			0,88 W			0,95 W		
Vsor. non-chargée	Min. 24 V			Min. 24 V			Min. 24 V		
Vsortie chargée	Min. 11,5 V		Min. 9 V	Min. 12,5 V		Min. 10 V	Min. 13,5 V		Min. 11 V
Isortie max	50 mA		60 mA	50 mA		60 mA	50 mA		60 mA
	IIC	IIB	IIA	IIC	IIB	IIA	IIC	IIB	IIA
Co	80 nF	640 nF	2,1 µF		640 nF	2,1 µF		640 nF	2,1 µF
Lo	2,69 mH	10,8 mH	20,8 mH		9,1 mH	17,6 mH		7,8 mH	15,1 mH
Lo/Ro	44 µH/Ω	176 µH/Ω	353 µH/Ω		163 µH/Ω	327 µH/Ω		150 µH/Ω	301 µH/Ω

### Sortie relais :

Relais d'état en zone non-dangereuse :

Tension max. .... 125 Vca / 110 Vcc  
 Courant max..... 0,5 A ca / 0,3 A cc  
 Puissance max..... 62,5 VA / 32 W

**Approbation marine:**

Det Norske Veritas, Ships & Offshore ..... En cours

**Approbation GOST R:**

VNIIFTRI, Cert No..... En cours

**Certification SIL:**

exida, Cert No. .... XXXXXXXX

**Agréments et homologations:****Standard:**

CEM 2004/108/CE ..... EN 61326-1

LVD 2006/95/CE..... EN 61010-1

ATEX 94/9/CE..... EN 60079-0, -11, -15, -26  
et EN 61241-0, -11

IECEX..... IEC 60079-0, -11, -15 et -26  
IEC 61241-0 et -11

c FM us ..... FM 3600, 3611, 3810

CSA E60079-0, -15

CSA 22.2 -25, -142, -213

ANSI/ISA-12.00.01 / 12.12.02

UL, Standard for Safety ..... UL 61010-1

SIL ..... IEC 61508

## Indications erreurs matériels / logiciels

Indication erreur matériel :		
Recherche erreurs	Affichage	Cause d'erreur
Vérification de la communication entre 4501 / 9203	NO.CO	Erreur de connexion
Erreur de l'EEProm - vérifier la configuration	FL.ER	Erreur de config. ou discordance crc, la config. de récupération a été chargée
Erreur matériel	DE.ER	Config. de récupération non valable dans le module
Erreur matériel	FC.ER	Somme de contrôle de code non valable en 4501
Erreur de l'EEProm - vérifier la configuration	CO.ER	Config. non valable (CRC ou données)
Erreur matériel	CA.ER	Erreur d'étalonnage usine
Erreur matériel	HW.ER	Discordance de la configuration du matériel
Erreur matériel	OC.ER	Erreur de comm. du contrôleur de sortie principal
Erreur matériel	MS.ER	Alim. interne principal en dehors des limites
Erreur matériel	MI.ER	Erreur de l'autotest d'initialisation principale
Erreur matériel	MC.ER	Erreur de l'autotest principal du flash ou du ram

! Les indications d'erreurs clignotent une fois par seconde. Un texte d'aide explique l'erreur.

Des erreurs affectant les deux voies sont affichées comme erreur de la voie 1 - et la ligne affichant la voie 2 reste vide.

Une erreur matérielle peut être corrigée de deux manières. Soit en parcourant les menus (si l'autre voie doit rester en fonction) soit en déconnectant et puis reconnectant l'alimentation du module.

# CONNEXIONS

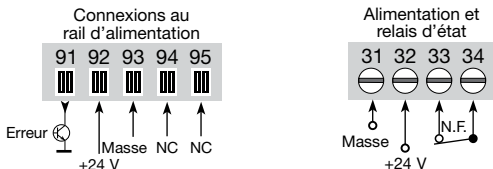

NC = Pas de connexion

## Entrées:

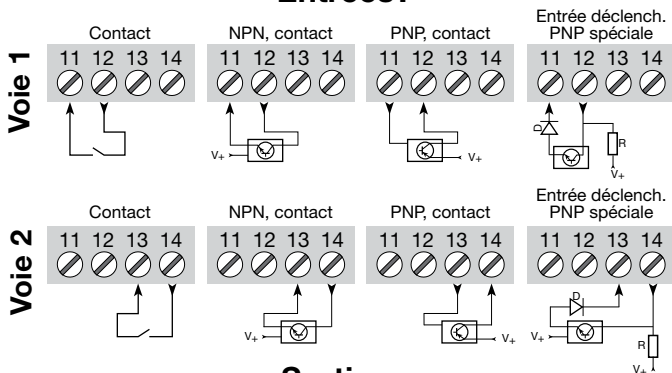

# SCHEMA DE PRINCIPE

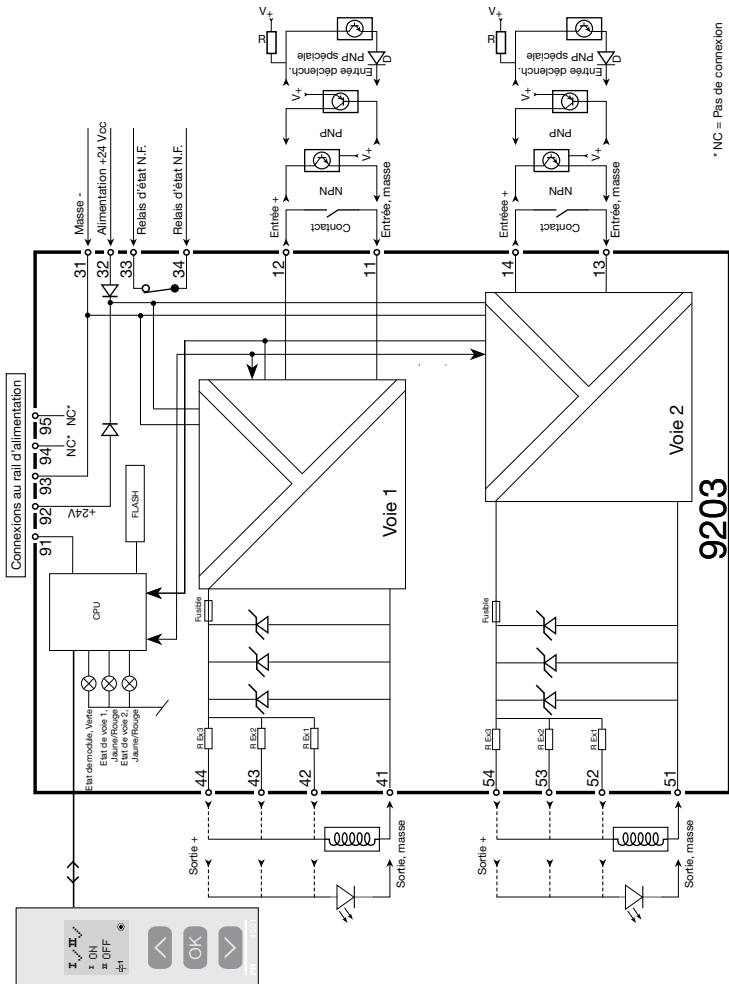

\* NC = Pas de connexion

## Indications d'erreur signal sans la façade 4501

Liste d'indications des DEL et signaux d'erreurs					
Etat	DEL verte	Voie 1 : Jaune/Rouge	Voie 2 : Jaune/Rouge	Relais d'état, N.F.	Etat de signal pour le rail
Module OK	Clignotante			Excité	OFF
Pas d'alimentation	OFF	OFF	OFF	Désexcité	ON
Défaut module	OFF	Rouge	Rouge	Désexcité	ON
Voie 1, sortie ON	Clignotante	Jaune		Excité	OFF
Voie 1, sortie OFF	Clignotante	OFF		Excité	OFF
Voie 2, sortie ON	Clignotante		Jaune	Excité	OFF
Voie 2, sortie OFF	Clignotante		OFF	Excité	OFF

## CONFIGURATION / OPERATION DES TOUCHES DE FONCTIONS

Documentation pour le diagramme de programmation.

### Généralités:

Lors de la configuration du 9203 vous êtes guidés tout au long des paramètres du menu ; ainsi vous pouvez choisir le réglage qui correspond à votre application. Pour chaque menu il y a un texte d'aide qui défile en ligne 3 de l'indicateur.

La configuration se fait à l'aide des 3 touches de fonctions :

- ⊖ Incrémenter la valeur numérique ou choisir le paramètre suivant
- ⊕ Décrémenter la valeur numérique ou choisir le paramètre précédent
- Ⓚ Valider les valeurs choisies et fin du menu

Une fois la configuration terminée, l'indicateur retournera sur l'état défaut 1.0.

En appuyant et maintenant la touche Ⓚ l'indicateur retourne au menu précédent ou sur l'état défaut (1.0) sans sauvegarde des modifications éventuelles apportées à la configuration.

Si aucune touche n'est activée pendant 1 minute, l'indicateur retournera sur l'état défaut sans sauvegarde des modifications éventuelles apportées à la configuration.

## Informations complémentaires

**Protection par mot de passe:** L'accès à la programmation peut être bloqué par un mot de passe. Ce mot de passe est sauvegardé dans le module afin d'assurer un haut niveau de protection contre les modifications non autorisées. Le mot de passe usine «2008» permet l'accès à tous les menus de configuration.

## Informations relatives aux erreurs de signal et de module sur la façade 4501

La façade 4501 peut être configurée pour afficher l'état de sortie, le courant de sortie ou le numéro de repère pour les deux voies. En cas d'erreur matérielle, un texte d'aide expliquant l'erreur sera affiché.

## Fonctions avancées

L'unité donne accès à un certain nombre de fonctions avancées qui sont accessibles en répondant « Oui » à « adv.set ».

**Configuration de l'affichage:** Il est possible de régler la luminosité et le rétro-éclairage. Enregistrement d'un numéro de repère à 5 caractères alpha-numériques. Sélection de l'affichage en ligne 2 et 3 de l'indicateur - choix entre: état de sortie, courant de sortie ou numéro de repère. En sélectionnant "ALT" l'affichage alterne entre les options d'affichage.

**Mot de passe:** Ici vous pouvez choisir un mot de passe allant de 0000 à 9999 afin de protéger la programmation. L'unité est livrée sans mot de passe.

**Langue:** Dans le menu « LANG », vous pouvez sélectionner 7 différentes langues pour le texte d'aide. Choix entre: Anglais, allemand, français, italien, espagnol, suédois et danois.

**Safety Integrity Level (SIL):** Voir le manuel de sécurité (Safety Manual - en Anglais) pour informations supplémentaires.



## DIAGRAMME DE PROGRAMMATION

Si aucune touche n'est actionnée pendant 1 minute, l'indicateur retournera sur l'état défaut sans sauvegarde des modifications éventuelles apportées à la configuration.

- ⊙ Incrémenter la valeur / choisir paramètre suivant
- ∨ Décrémenter la valeur / choisir paramètre précédent
- ⊗ Valider les valeurs choisies et fin du menu

Maintien ⊗ Retour au menu précédent / retour au menu 1.0 sans sauvegarde.

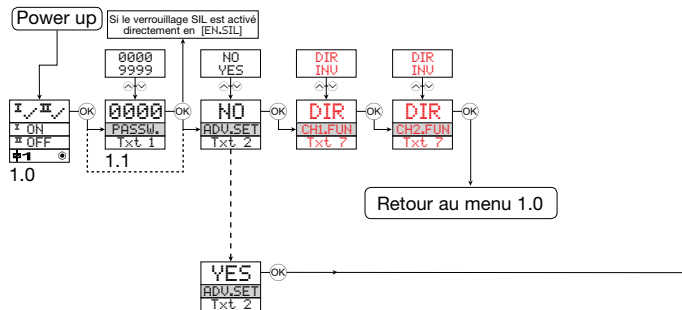

1.0 = Etat défaut

Ligne 1 affiche l'état de la voie 1 et la voie 2.

Ligne 2 affiche l'état de sortie de la voie 1, courant de sortie ou numéro de repère.

Ligne 3 affiche l'état de sortie de la voie 2, courant de sortie ou numéro de repère.

Ligne 4 affiche l'état SIL (ouvert / verrouillé).

1.1 = Seulement si l'indicateur est protégé par un mot de passe

1.2 = Seulement si un mot de passe a été choisi.

Symboles en ligne 1 :

⊙ = OK. ⊗ clignotant = erreur.

Symboles en ligne 2 et 3 :

⊙ ON = voie 1 ON

⊗ OFF = voie 2 OFF.

Symboles en ligne 4 :

Point statique = verrouillage SIL

Point clignotant = aucun verrouillage SIL

⊕ = la sortie est active.

**Texte rouge** signifie des paramètres de sécurité dans une configuration SIL. Voir le manuel de sécurité (Safety Manual - en Anglais) pour informations supplémentaires.

## DIAGRAMME DE PROGRAMMATION, REGLAGE AVANCE (ADV.SET)

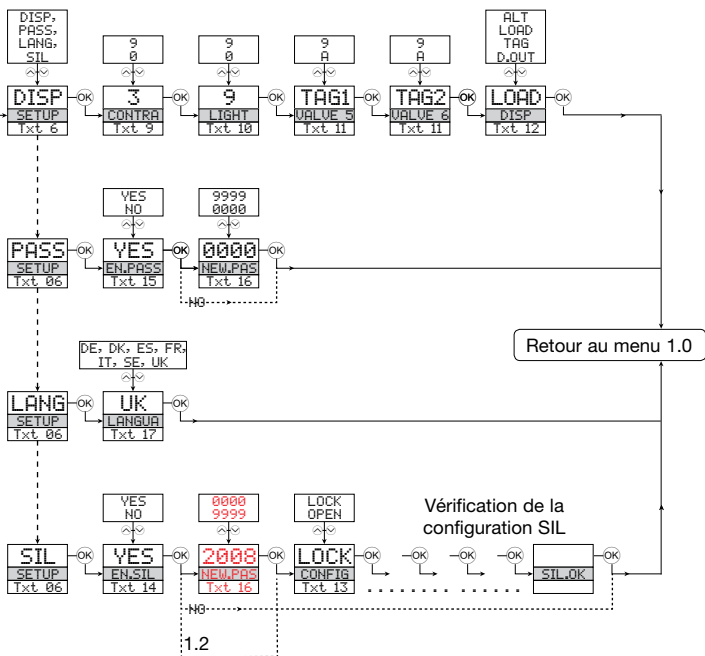

## MENU DEROULANT EN LIGNE 3 DE L'INDICATEUR

- [01] Entrer mot de passe correct
- [02] Aller dans le menu de configuration avancée?
- [06] Aller dans la configuration langue
  - Aller dans la configuration du mot de passe
  - Aller dans la configuration d'affichage
  - Aller dans la configuration SIL
- [07] Sélectionner fonction voie directe
  - Sélectionner fonction voie inverse
- [09] Ajuster le contraste LCD
- [10] Ajuster le rétro-éclairage LCD
- [11] Entrer numéro repère de 5 caractères
- [12] Afficher l'état de la sortie en ligne 3
  - Afficher la charge de la sortie en ligne 3
  - Numéro repère affiché en ligne 3
  - Alterner les informations affichées
- [13] Etat de la configuration SIL (Ouverte / Verrouillée)
- [14] Permettre verrouillage de la configuration SIL?
- [15] Permettre protection par mot de passe?
- [16] Entrer nouveau mot de passe
- [17] Sélectionner langue
- [20] Pas de communication - contrôler les connexions
- [21] Erreur de l'EEPROM - vérifier la configuration
- [22] Erreur matériel

# VENTIL- / ALARMTREIBER

9203

## INHALTSVERZEICHNIS

Warnung .....	62
Zeichenerklärungen.....	62
Sicherheitsregeln.....	62
Zerlegung des Systems 9000 .....	64
EC-Konformitätserklärung.....	65
Erweiterte Merkmale .....	66
Verwendung.....	66
Technische Merkmale.....	66
Anwendungen .....	67
PR 4501 Display- / Programmierfront.....	68
Bestellangaben: 9203B .....	69
Elektrische Daten .....	69
Visualisierung im 4501 bei Hardware / Software Fehler ....	73
Anschlüsse .....	74
Blockdiagramm .....	75
Signalfehler Erkennung ohne Frontdisplay .....	76
Konfiguration / bedienung der funktionstasten.....	76
Flussdiagramm.....	78
Flussdiagramm, erweiterte Einstellungen (ADV.SET) .....	79
Scrollender Hilfstext im Display Zeile 3 .....	80
Appendix .....	81
IECEx Installation Drawing .....	82
ATEX Installation Drawings, UK, FR, DE, DK.....	84
FM Installation Drawing.....	92
Safety manual.....	94



## WARNUNG

Die folgende Maßnahmen sollten nur in spannungslosem Zustand des Gerätes und unter ESD-sicheren Verhältnisse durchgeführt werden:

Installation, Montage und Demontage von Leitungen.  
Fehlersuche im Gerät.

**Reparaturen des Gerätes und Austausch von Sicherungen dürfen nur von PR electronics A/S vorgenommen werden.**



## WARNUNG

Die Frontplatte des Gerätes darf nicht geöffnet werden, weil hierdurch die Kontakte zur Kontaktierung des Frontdisplays 4501 beschädigt werden können. Das Gerät enthält keine internen DIP-Schalter oder Programmierbrücken.

## ZEICHENERKLÄRUNGEN



**Dreieck mit Ausrufungszeichen:** Das Handbuch ist sorgfältig durchzulesen vor Montage und Inbetriebnahme des Gerätes, um schweren Verletzungen oder mechanischer Zerstörung zu vermeiden.



**Die CE-Marke** ist das sichtbare Zeichen dafür, dass das Gerät die Vorschriften erfüllt.



**Doppelte Isolierung** ist das Symbol dafür, dass das Gerät besondere Anforderungen an die Isolierung erfüllt.



**Ex-Geräte** sind entsprechend der ATEX Direktive für die Verwendung in Verbindung mit Installationen in explosionsgefährdeter Umgebung zuge lassen. Siehe Installationszeichnungen im Appendix.

## SICHERHEITSREGELN

### DEFINITIONEN

Gefährliche Spannungen sind definitionsgemäß die Bereiche: 75...1500 Volt Gleichspannung und 50...1000 Volt Wechselspannung.

Techniker sind qualifizierte Personen, die dazu ausgebildet oder angelernt sind, eine Installation, Bedienung oder evtl. Fehlersuche auszuführen, die sowohl technisch als auch sicherheitsmäßig vertretbar ist.

Bedienungspersonal sind Personen, die im Normalbetrieb mit dem Produkt die Drucktasten oder Potentiometer des Produktes einstellen bzw. bedienen und die mit dem Inhalt dieses Handbuches vertraut gemacht wurden.

## **EMPFANG UND AUSPACKEN**

Packen Sie das Gerät aus, ohne es zu beschädigen und kontrollieren Sie beim Empfang, ob der Gerätetyp Ihrer Bestellung entspricht. Die Verpackung sollte beim Gerät bleiben, bis dieses am endgültigen Platz montiert ist.

## **UMGEBUNGSBEDINGUNGEN**

Direkte Sonneneinstrahlung, starke Staubentwicklung oder Hitze, mechanische Erschütterungen und Stöße sind zu vermeiden; das Gerät darf nicht Regen oder starker Feuchtigkeit ausgesetzt werden. Bei Bedarf muss eine Erwärmung, welche die angegebenen Grenzen für die Umgebungstemperatur überschreitet, mit Hilfe eines Kühlgebläses verhindert werden.

Das Gerät muss im Verschmutzungsgrad 2 oder besser installiert werden.

Das Gerät ist so konzipiert, dass es auch in einer Einsatzhöhe von bis zu 2 000 m noch sicher funktioniert.

## **INSTALLATION**

Das Gerät darf nur von Technikern angeschlossen werden, die mit den technischen Ausdrücken, Warnungen und Anweisungen im Handbuch vertraut sind und diese befolgen.

Sollten Zweifel bezüglich der richtigen Handhabung des Gerätes bestehen, sollte man mit dem Händler vor Ort Kontakt aufnehmen. Sie können aber auch direkt mit **PR electronics GmbH, Im Erlengrund 26, D-46149 Oberhausen, (Tel.: (0) 208 62 53 09-0)** oder mit **PR electronics A/S, Lerbakken 10, DK-8410 Rønne, Dänemark (Tel.: +45 86 37 26 77)** Kontakt aufnehmen.

Der Einsatz von verdrillter Leitung ist nicht erlaubt außer die Enden sind mit Aderendhülsen versehen.

Eine Beschreibung von Eingangs- / Ausgangs- und Versorgungsanschlüssen befindet sich auf dem Blockschaltbild und auf dem seitlichen Schild.

Das Gerät ist mit Feldverdrahtungsklemmen ausgestattet und wird von einem Netzteil mit doppelter / verstärkter Isolierung versorgt. Der Netzschalter sollte leicht zugänglich und in der Nähe des Gerätes sein. Der Netzschalter sollte mit einem Schild gekennzeichnet sein, auf dem steht, dass durch Betätigung dieses Schalters das Gerät vom Netz genommen wird.

Für den Anschluss auf der Power Rail 9400 wird das Gerät über das Power Control Unit 9410 versorgt.

Die ersten beiden Ziffern der Seriennummer geben das Produktionsjahr an.

### **KALIBRIERUNG UND JUSTIERUNG**

Während der Kalibrierung und Justierung sind die Messung und der Anschluss externer Spannungen entsprechend diesem Handbuch auszuführen, und der Techniker muss hierbei sicherheitsmäßig einwandfreie Werkzeuge und Instrumente benutzen.

### **BEDIENUNG IM NORMALBETRIEB**

Das Bedienungspersonal darf das Gerät nur dann einstellen oder bedienen, wenn diese auf vertretbare Weise in Schalttafeln o. ä. fest installiert sind, sodass die Bedienung keine Gefahr für Leben oder Material mit sich bringt. D. h., es darf keine Gefahr durch Berührung bestehen, und das Gerät muss so plaziert sein, dass es leicht zu bedienen ist.

### **REINIGUNG**

Das Gerät darf in spannungslosem Zustand mit einem Lappen gereinigt werden, der mit destilliertem Wasser leicht angefeuchtet ist.

### **HAFTUNG**

In dem Umfang, in welchem die Anweisungen dieses Handbuches nicht genau eingehalten werden, kann der Kunde PR electronics gegenüber keine Ansprüche geltend machen, welche ansonsten entsprechend der eingegangenen Verkaufsvereinbarungen existieren können.

## **ZERLEGUNG DES SYSTEMS 9000**

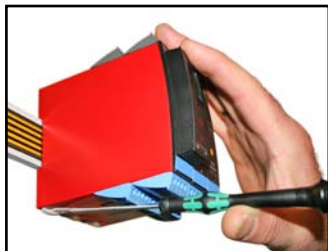

**Abbildung 1:**

Das Gerät wird von der Power Rail gelöst, indem man den unteren Verschluss löst.

# EC-KONFORMITÄTSERKLÄRUNG

Als Hersteller bescheinigt

**PR electronics A/S**  
**Lerbakken 10**  
**DK-8410 Rønde**

hiermit für das folgende Produkt:

**Typ: 9203**  
**Name: Ventil- / Alarmtreiber**

die Konformität mit folgenden Richtlinien und Normen:

Die EMV Richtlinien 2004/108/EG und nachfolgende Änderungen

**EN 61326-1 : 2006**

Zur Spezifikation des zulässigen Erfüllungsgrades, siehe die Elektrische Daten des Gerätes.

Die Niederspannungsrichtlinien 2006/95/EG und nachfolgende Änderungen

**EN 61010-1 : 2001**

Die ATEX Richtlinien 94/9/EG und nachfolgende Änderungen

**EN 61241-0:2006, EN 61241-11:2006, EN 60079-0:2006,**  
**EN 60079-11:2007, EN 60079-15:2005, EN 60079-26:2007**  
**ATEX-Zertifikat: KEMA 07ATEX0147 X**

Zulassungsstelle:

**KEMA Quality B.V. (0344)**  
**Utrechtseweg 310, 6812 AR Arnhem**  
**P.O. Box 5185, 6802 ED Arnhem**  
**The Netherlands**

Rønde, 13. Januar 2010



Kim Rasmussen  
Unterschrift des Herstellers

## **VENTIL- / ALARMTREIBER 9203**

- *Universeller Ex-Treiber für Ventile, akustischen Alarme und LED's*
- *Erweiterte Selbstdiagnose*
- *1 oder 2 Kanäle*
- *Kann separat über Klemmenanschluss oder über die Power Rail 9400 versorgt werden*
- *SIL 2-zertifiziert über Full Assessment*

### **Erweiterte Merkmale**

- Universeller Ex-Treiber zur Ansteuerung von Magnetventilen etc. mit verschiedensten Ex-Daten der drei integrierten Ex-Barrieren.
- Zwei Hardware-Versionen ermöglichen die Auswahl zwischen „Low“ (35 mA) oder „High“ (60 mA) Stromausgang.
- Konfiguration und Überwachung über das abnehmbare Frontdisplay (PR 4501).
- Auswahl einer direkten oder invertierten Funktion für jeden Kanal mit PR 4501 und die Möglichkeit den Ausgangsstrom für den gefährdeten Bereich der entsprechenden Applikation anzupassen.
- Optionale Überwachung des Ausgangsstromes zum Ex-Bereich mit dem 4501.
- Optionale redundante Versorgung über Power Rail und / oder separate Versorgung.

### **Verwendung**

- Das Gerät kann in sicheren Bereichen und in Zone 2 / div. 2 eingesetzt werden und Signale in die Zonen 0, 1, 2, 20, 21 und 22 übertragen.
- Ex-Treiber zur Kontrolle von ON / OFF Magnetventilen, akustischen Alarmen und LED's im Ex-Bereich.
- Das 9203 wird über NPN/PNP-Signale oder Schaltsignale angesteuert.
- Meldung von internen Fehlerzuständen mittels des Statusrelais und/oder der Sammelstörmeldung über die Power Rail.
- Das 9203 wurde für SIL 2-Anwendungen entwickelt und zertifiziert entsprechend den Anforderungen der Richtlinie IEC 61508.

### **Technische Merkmale**

- 1 grüne und 2 gelbe/rote Leuchtdioden in der Front des Gerätes zeigen den normalen Betrieb und Fehlfunktionen an.
- 2,6 kVAC galvanische Trennung zwischen Eingang, Ausgang und Versorgung.

# ANWENDUNGEN

## Ausgangs- signale:

Kanal 1

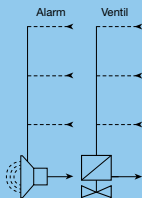

Kanal 2

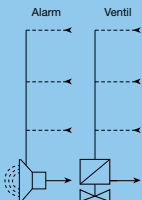

**Zone 0, 1, 2,  
20, 21, 22 /  
Cl. I/II/III, div. 1  
gr. A-G**

## Eingangssignale:

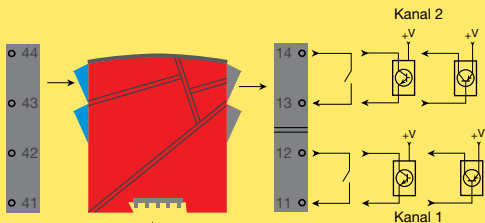

Power rail

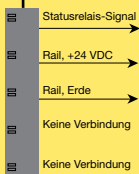

## Versorgungsanschluss:

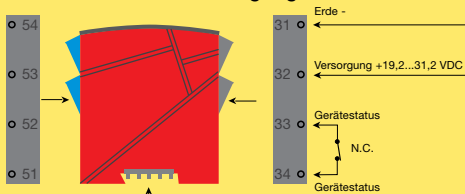

Versorgung über  
Power Rail

**Zone 2 / Cl. 1, Div. 2, gr. A-D oder sicheres Bereich**

# PR 4501 DISPLAY- / PROGRAMMIERFRONT



## Funktionalität

Die einfache Menüstruktur leitet automatisch durch die relevanten Einstellungen. Der scrollende Hilfetext macht es sehr einfach diese Geräte einzusetzen. Sie finden weitere Beschreibungen der Funktionen und Programmierungsmöglichkeiten im Abschnitt "Konfiguration / Bedienung der Funktionstasten".

## Anwendungen

- Kommunikationsschnittstelle zur Änderung der operativen Parameter im 9203.
- Wenn das Gerät im Prozess integriert ist, zeigt das Display die entsprechenden Prozesswerte und den jeweiligen Prozessstatus an.

## Technische Merkmale

- LCD Display mit 4 Zeilen; Zeile 1 (5,57 mm hoch) zeigt den status jeder Kanal (OK oder Fehler), Zeile 2 (3.33 mm hoch) den Ausgang für Kanal 1 (ON/OFF), Zeile 3 (3.33 mm hoch) den Ausgang für Kanal 2 (ON/OFF), und Zeile 4 den Status der SIL-Konfiguration (offen / verriegelt) an. Statischer Punkt = SIL-verriegelt, blinkender Punkt = nicht SIL-verriegelt. Zeile 4 zeigt auch an, ob der Ausgang aktiv ist.
- Zum Schutz der jeweiligen Konfiguration gegen unbefugte Änderungen kann der Zugang zum Menü durch ein Passwort blockiert werden.

## Montage / Installation

- Stecke das 4501 auf die Front des 9203.

## Bestellangaben: 9203B



Typ	Ex-Barriere [Ex ia]	Kanäle
9203B	Low current . . . : 1	Einfach . . : A Zweifach . : B
	High current . . . : 2	Einfach . . : A

**4501 = Display / programming front**

**9400 = Power Rail**

### Elektrische Daten

Umgebungstemperatur ..... -20...+60°C

Lagertemperatur..... -20...+85°C

### Allgemeine Daten:

Versorgungsspannung..... 19,2...31,2 VDC

Stromverbrauch, max..... ≤ 3,5 W (2 Kanäle)

Sicherung ..... 1,25 A T / 250 VAC

Isolationsspannungen, Test / Betrieb:

Eingang / Ausgang / Versorgung ..... 2,6 kVAC / 250 VAC

Ausgang 1 zum Ausgang 2 ..... 1,5 kVAC / 150 VAC verstärkt

Statusrelais zur Versorgung ..... 1,5 kVAC / 150 VAC verstärkt

EMV Störspannungseinfluss .....	< ±0,5% d. Messsp.
---------------------------------	--------------------

Erweiterte EMV Störfestigkeit:

NAMUR NE 21, Kriterium A, Burst.....	< ±1% d. Messsp.
--------------------------------------	------------------

Kommunikationsschnittstelle ..... Programmierfront 4501

Kalibrierungstemperatur..... 20...28°C

Leitungsquerschnitt (min...max.) ..... 0,13...2,08 mm<sup>2</sup> / AWG 26...14  
Litzendraht

Klemmschraubenanzugsmoment..... 0,5 Nm

Relative Luftfeuchtigkeit..... < 95% RH (nicht kond.)

Abmessungen, ohne Frontdisplay (HxBxT). 109 x 23,5 x 104 mm

Abmessungen, mit Frontdisplay (HxBxT).... 109 x 23,5 x 116 mm

Schutzart ..... IP20

Gewicht ..... 170 g / 185 g mit 4501

**NPN und mechanischer Schalter:**

Trig-Niveau LOW .....	≤ 2,0 VDC
Trig-Niveau HIGH .....	≥ 4,0 VDC
Max. externe Spannung .....	28 VDC
Eingangsimpedanz .....	3,50 kΩ

**PNP:**

Trig-Niveau LOW .....	≤ 8,0 VDC
Trig-Niveau HIGH .....	≥ 10,0 VDC
Max. externe Spannung .....	28 VDC
Eingangsimpedanz .....	3,50 kΩ

**Spezial PNP Trig-Eingang:**

Wenn das Eingangssignal von einem Gerät kommt, bei dem der Ausgang als Open-Kollektor mit Pull-up-Widerstand ausgeführt ist, muss eine Diode in Reihe mit dem Eingangssignal angeschlossen werden. Weitere Details auf Seite 74 in den Anschlusszeichnungen.

**Ausgänge:**

Ausgangswelligkeit..... < 40 mV RMS

**Ex- / I.S.-Daten:**

	9203B1A / 9203B1B								
	Klemme 41-42 / 51-52			Klemme 41-43 / 51-53			Klemme 41-44 / 51-54		
	Uo	Io	Po	V <sub>Aus.</sub> unbelastet	V <sub>Aus.</sub> belastet	I <sub>Aus.</sub> max	IIC	IIB	IIA
	28 V	93 mA	0,65 W	Min. 24 V	Min. 12,5 V	35 mA	IIC	IIB	IIA
	28 V	100 mA	0,70 W	Min. 24 V	Min. 13,5 V	35 mA	IIC	IIB	IIA
	28 V	110 mA	0,77 W	Min. 24 V	Min. 14,5 V	35 mA	IIC	IIB	IIA
Co	80 nF	640 nF	2,1 μF	80 nF	640 nF	2,1 μF	80 nF	640 nF	2,1 μF
Lo	4,2 mH	16,8 mH	32,6 mH	3,5 mH	14,2 mH	27,6 mH	2,9 mH	11,8 mH	22,8 mH
Lo/Ro	54 μH/Ω	218 μH/Ω	436 μH/Ω	50 μH/Ω	201 μH/Ω	402 μH/Ω	46 μH/Ω	184 μH/Ω	369 μH/Ω

	9203B2A								
	Klemme 41-42			Klemme 41-43			Klemme 41-44		
	U <sub>o</sub>	28 V			28 V			28 V	
I <sub>o</sub>	115 mA			125 mA			135 mA		
P <sub>o</sub>	0,81 W			0,88 W			0,95 W		
V <sub>Aus.</sub> unbelastet	Min. 24 V			Min. 24 V			Min. 24 V		
V <sub>Aus.</sub> belastet	Min. 11,5 V	Min. 9 V		Min. 12,5 V	Min. 10 V		Min. 13,5 V	Min. 11 V	
I <sub>Aus.</sub> max	50 mA	60 mA		50 mA	60 mA		50 mA	60 mA	
	IIC	IIB	IIA	IIC	IIB	IIA	IIC	IIB	IIA
Co	80 nF	640 nF	2,1 μF		640 nF	2,1 μF		640 nF	2,1 μF
Lo	2,69 mH	10,8 mH	20,8 mH		9,1 mH	17,6 mH		7,8 mH	15,1 mH
Lo/Ro	44 μH/Ω	176 μH/Ω	353 μH/Ω		163 μH/Ω	327 μH/Ω		150 μH/Ω	301 μH/Ω

### Relaisausgang:

Statusrelais in sicheren Bereich:

Max. Spannung ..... 125 VAC / 110 VDC  
 Max. Strom..... 0,5 A AC / 0,3 A DC  
 Max. Leistung..... 62,5 VA / 32 W

**Marine-Zulassung:**

Det Norske Veritas, Ships & Offshore ..... Angefordert

**GOST R Zulassung:**

VNIIFTRI, Cert No..... Angefordert

**SIL-Zertifizierung:**

exida, Cert No. .... XXXXXXXX

**Eingehaltene Richtlinien:****Norm:**

EMV 2004/108/EC..... EN 61326-1

LVD 2006/95/EC..... EN 61010-1

ATEX 94/9/EC..... EN 60079-0, -11, -15, -26  
und EN 61241-0, -11

IECEx..... IEC 60079-0, -11, -15 und -26  
IEC 61241-0 und -11

c FM us ..... FM 3600, 3611, 3810

CSA E60079-0, -15

CSA 22.2 -25, -142, -213

ANSI/ISA-12.00.01 / 12.12.02

UL, Standard for Safety ..... UL 61010-1

SIL ..... IEC 61508

## Visualisierung im 4501 bei Hardware / Software Fehler

Anzeige bei Hardware Fehler:		
Fehlersuche	Anzeige	Grund
Kommunikationstest 4501 / 9203	NO.CO	Verbindungsfehler
EEProm error - überprüfe Konfiguration	FL.ER	Konfigurationsfehler oder CRC Versatz, gespeicherte Konfiguration wird geladen
Hardware Fehler	DE.ER	Ungültige Konfiguration im Gerät
Hardware Fehler	FC.ER	Ungültiger Code Checksumme im 4501
EEProm Fehler - überprüfe Konfiguration	CO.ER	Ungültige Konfiguration (CRC oder Daten)
Hardware Fehler	CA.ER	Werkskalibrierungsfehler
Hardware Fehler	HW.ER	HW Setup - Konfiguration Versatz
Hardware Fehler	OC.ER	Main Output Controller Kommunikationsfehler
Hardware Fehler	MS.ER	Interne Hauptversorgung außerhalb der Grenzen
Hardware Fehler	MI.ER	Hauptinitialisierung Selbsttest fehlerhaft
Hardware Fehler	MC.ER	Main Flash oder RAM Selbsttest fehlerhaft

! Alle Fehleranzeigen im Display blinken im Sekundentakt. Der Hilfstext erklärt den Fehler.

Fehler die in beiden Kanälen auftreten, werden als Fehler im Kanal 1 angezeigt – und die Anzeige Kanal 2 ist leer.

Hardware Fehler können in zwei Arten zurückgesetzt werden. Erstens schrittweise durch das Menü gehen (wenn der andere Kanal weiterarbeiten soll) oder kurzfristiges Wegschalten der Versorgungsspannung.

# ANSCHLÜSSE

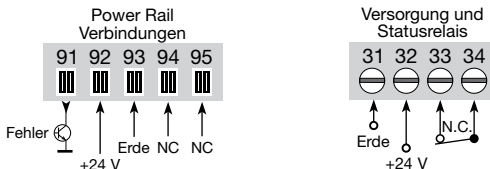

NC = Keine Verbindung

## Eingänge:

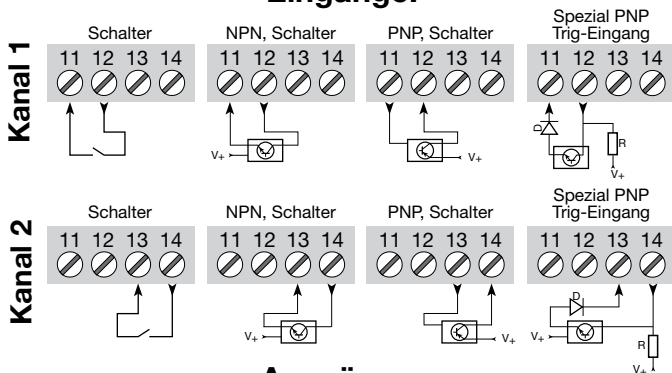

## Ausgänge:

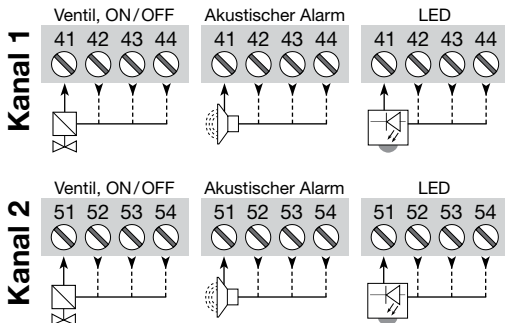

# BLOCKDIAGRAMM

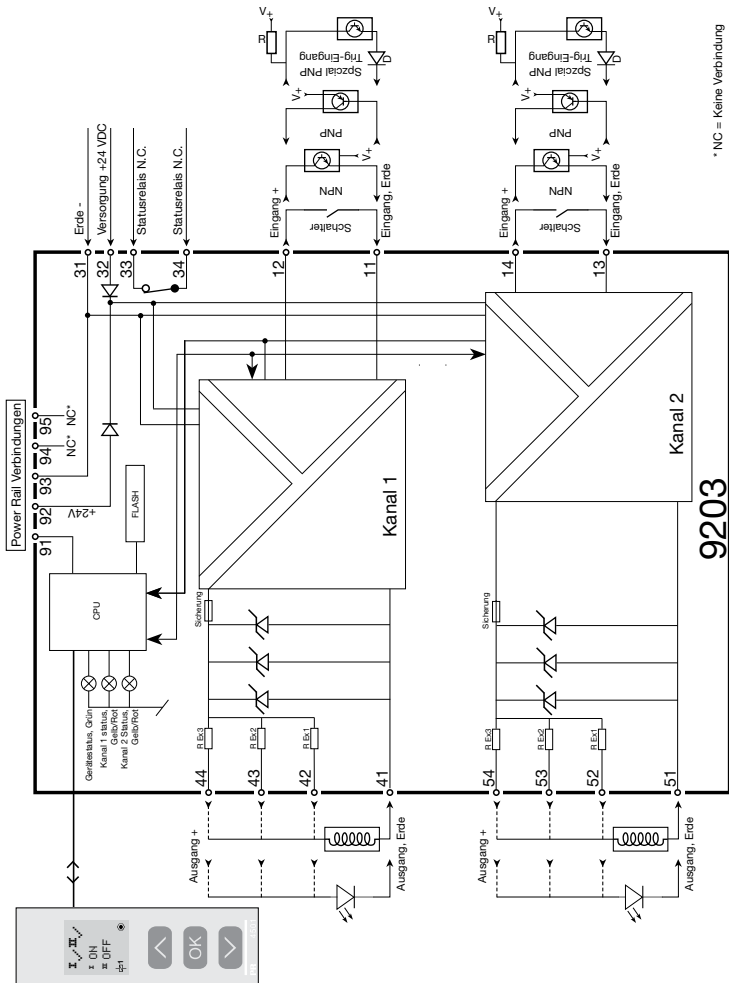

\* NC = Keine Verbindung

## Signalfehler Erkennung ohne Frontdisplay

Liste der LED und Fehlersignalanzeigen					
Status	Grüne LED	Kanal 1: Gelb / Rot	Kanal 2: Gelb / Rot	Statusrelais, N.C.	Power Rail Signalstatus
Gerät OK	Blinkt			Angesteuert	OFF
Keine Versorgung	OFF	OFF	OFF	Abgefallen	ON
Gerät defekt	OFF	Rot	Rot	Abgefallen	ON
Kanal 1, Ausgang ON	Blinkt	Gelb		Angesteuert	OFF
Kanal 1, Ausgang OFF	Blinkt	OFF		Angesteuert	OFF
Kanal 2, Ausgang ON	Blinkt		Gelb	Angesteuert	OFF
Kanal 2, Ausgang OFF	Blinkt		OFF	Angesteuert	OFF

## KONFIGURATION / BEDIENUNG DER FUNKTIONSTASTEN

Dokumentation für das Flussdiagramm.

### Grundsätzliches

Bei der Konfiguration des 9203 werden Sie durch alle Parameter geleitet und Sie können die Einstellungen wählen, welche zur Applikation passt. Für jedes Menü existiert ein scrollender Hilfetext welcher automatisch in der 3. Zeile im Display gezeigt wird.

Die Konfiguration wird mittels der 3 Funktionstasten durchgeführt:

- erhöht den numerischen Wert oder wählt nächsten Parameter
- setzt den numerischen Wert herab oder wählt nächsten Parameter
- übernimmt den gewählten Wert und beendet das Menü

Wenn eine Konfiguration eingegeben worden ist, kehrt das Display auf den Menüpunkt 1.0 zurück

Bei drücken und halten von  springt man zurück zum vorherigen Menü oder in den Normal-Zustand (1.0) ohne die geänderten Werte oder Parameter zu speichern.

Wenn für 1 Minute keine Taste betätigt wird, geht das Display in den Normalzustand zurück, ohne die geänderten Werte oder Parameter zu speichern.

## Weitere Erklärungen

**Passwortschutz:** Der Zugriff auf die Programmierung kann mit der Eingabe eines Passwortes blockiert werden. Das Passwort wird im Gerät gespeichert, um den höchsten Grad an Schutz gegen nicht autorisierte Änderungen der Konfiguration sicherzustellen. Bei Eingabe des Master-Passwortes 2008 sind alle Konfigurationsmenüs erreichbar.

## Signal- und Gerätefehler Informationen über das Display 4501

Das Frontdisplay kann so konfiguriert werden, das es den Ausgangsstatus, Ausgangsstrom oder die Messstellennummer für beide Kanäle anzeigt. Im Falle eines Hardware-Fehlers wird dieser mittels Hilfstext angezeigt.

## Hauptfunktionen

Das Gerät bietet Zugang zu verschiedenen Funktionen, welche mit "yes" bei der Abfrage „adv.set“ bestätigt werden müssen.

**Anzeigeeinstellungen:** Sie können Werte einstellen, wie z.B. Displaykontrast und Hintergrundhelligkeit sowie die Einstellung der TAG-Nummer mit 5 alphanumerischen Werten vornehmen. Auswahl funktioneller Anzeigewerte in Zeile 2 und 3 des Displays - wählen Sie zwischen Auslesen des Ausgangsstatus, Ausgangsstroms oder Tag-Nr. Bei der Einstellung „ALT“ wechselt die Anzeige zwischen den Anzeigewerten.

**Passwort:** Sie können ein Passwort zwischen 0000 und 9999 einstellen, um ein unbefugtes Verändern der Parameter zu vermeiden. Das Gerät wird werksseitig ohne Passwordeingabe ausgeliefert.

**Sprache:** Im Menü können Sie zwischen 7 verschiedenen Sprachen auswählen, die Sie mit Hilfetexten unterstützen. Sie können auswählen zwischen: UK, DE, FR, IT, ES, SE und DK.

**Safety Integrity Level (SIL):** Für Details sehen Sie bitte im Sicherheitshandbuch (Safety Manual) nach.



# FLUSSDIAGRAMM

Wenn für eine Dauer von 1 Minute keine Taste betätigt wird, kehrt das Display auf den Menüpunkt 1.0 zurück und eventuelle Änderungen in der Konfiguration werden nicht gespeichert.

⊙ Wert erhöhen / nächsten Parameter wählen

⊙ Wert herabsetzen / vorherigen Parameter Wählen

⊙ Parameter speicher und nächsten Parameter wählen

Halten ⊙ Zurück zum vorherigen Parameter / zurück zum Menüpunkt 1.0 ohne Speicherung von Änderungen

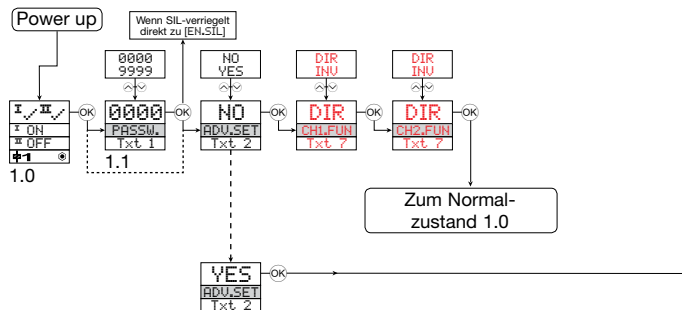

1.0 = Normalzustand

Zeile 1 zeigt den Status für Kanal 1 und Kanal 2.

Zeile 2 zeigt den Ausgangsstatus für Kanal 1, Ausgangsstrom oder Tag-nr.

Zeile 3 zeigt den Ausgangsstatus für Kanal 2, Ausgangsstrom oder Tag-nr

Zeile 4 zeigt wenn das Gerät SIL-verriegelt ist.

1.1 = Nur bei Passwortschutz.

1.2 = Wenn Passwort eingegeben.

Zeile 1 Symbole:

⊙ = OK. Blinkend ⊙ = Fehler.

Zeile 2 und 3 Symbole:

⊙ ON = Kanal 1 ON

⊙ OFF = Kanal 2 OFF.

Zeile 4 Symbole:

Statischer Punkt = SIL-verriegelt

Blinkender Punkt = nicht SIL verriegelt

⊙ = Ausgang ist aktiv.

Roter Text bedeutet Sicherheitsparameter in einer SIL Konfiguration. Siehe Sicherheitshandbuch (Safety Manual) für Details.

# FLUSSDIAGRAMM, ERWEITERTE EINSTELLUNGEN (ADV.SET)

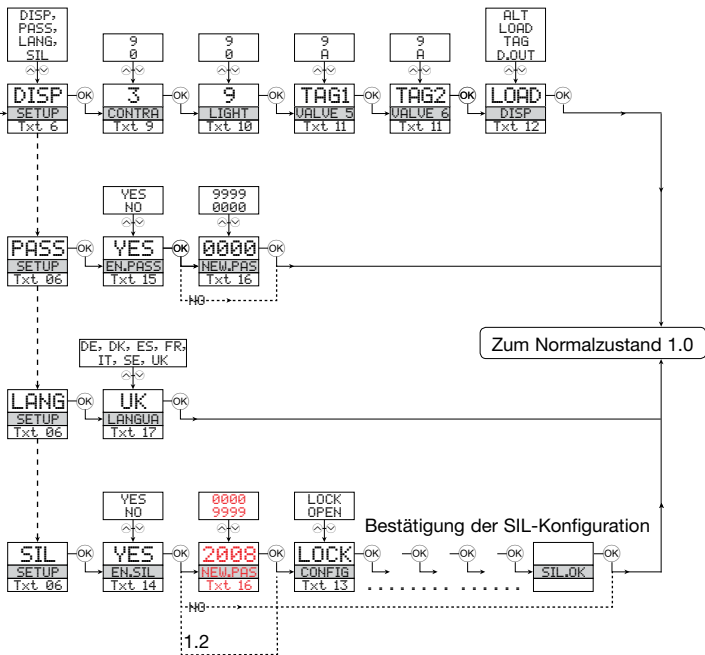

## SCROLLENDER HILFSTEXT IM DISPLAY ZEILE 3

- [01] Einstellung des korrekten Passwortes
- [02] Eingabe erweitertes Setup Menü?
- [06] Eingabe Sprachauswahl  
Eingabe Passwort Einstellung  
Eingabe Display Einstellung  
Eingabe SIL Einstellungen
- [07] Auswahl Direkte Kanalfunktion  
Auswahl Invertierte Kanalfunktion
- [09] Einstellung LCD Kontrast
- [10] Einstellung LCD Hintergrundbeleuchtung
- [11] Schreibe eine 5-Zeichen Geräte TAG Nummer
- [12] Ausgangsstatus wird im Display angezeigt  
Ausgangsbelastung wird im Display angezeigt  
Geräte TAG Nummer wird im Display angezeigt  
Wechselnde Information im Display
- [13] Konfiguration SIL Status (offen / verriegeln)
- [14] Aktivierung der SIL Konfiguration verriegeln?
- [15] Ermögliche Passwortschutz?
- [16] Eingabe Neuen Passwortes
- [17] Wähle Sprache
- [20] Keine Kommunikation - überprüfe Verbindungen
- [21] EEprom Fehler - überprüfe Konfiguration
- [22] Hardware-Fehler

# **APPENDIX**

**IECEX INSTALLATION DRAWING  
ATEX INSTALLATION DRAWINGS  
UK, FR, DE, DK  
FM INSTALLATION DRAWING  
SAFETY MANUAL**

## IECEX Installation drawing

**9203**

For safe installation of 9203B the following must be observed. The module shall only be installed by qualified personnel who are familiar with the national and international laws, directives and standards that apply to this area.

Year of manufacture can be taken from the first two digits in the serial number.

**4501**

For Installation in Zone 2 / Division 2 the following must be observed.

The 4501 programming module is to be used solely with PR electronics modules. It is important that the module is undamaged and has not been altered or modified in any way. Only 4501 modules free of dust and moisture shall be installed.

Certificate IECEX KEM 09.0001X

Marking Ex nA nC IIC T4 Gc  
[Ex ia Ga] IIC/II B/IIA  
[Ex ia Da] IIIC

Standards IEC60079-15:2005, IEC60079-11:2006, IEC60079-0:2007  
IEC60079-26:2006, IEC61241-0:2004, IEC61241-11:2005

Hazardous area Non Hazardous area  
Zone 0, 1, 2, 20, 21, 22 or Zone 2

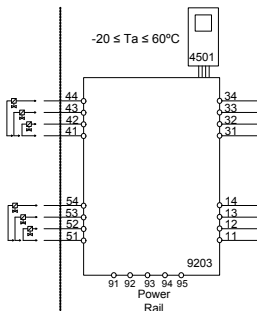

**Supply / Input**  
(terminal 11,12,13,14)  
(terminal 31,32,33,34)  
(terminal 91,92,93,94,95)  
 $U_m$ : 253 V, max. 400 Hz

Modul 9203B1A & 9203B1B Terminal 41-42 / 51-52			Co	Lo	Lo/Ro
Uo	28 V	IIC	80 nF	4.2 mH	54 µH/Ω
Io	93 mA	IIB	640 nF	16.8 mH	218 µH/Ω
Po	0.65 W	IIA	2.1 µF	32.6 mH	436 µH/Ω

Modul 9203B2A Terminal 41-42			Co	Lo	Lo/Ro
Uo	28 V	IIC	80 nF	2.69 mH	44 µH/Ω
Io	115 mA	IIB	640 nF	10.8 mH	176 µH/Ω
Po	0.81 W	IIA	2.1 µF	20.8 mH	353 µH/Ω

Modul 9203B1A & 9203B1B Terminal 41-43 / 51-53			Co	Lo	Lo/Ro
Uo	28 V	IIC	80 nF	3.5 mH	50 µH/Ω
Io	100 mA	IIB	640 nF	14.2 mH	201 µH/Ω
Po	0.70 W	IIA	2.1 µF	27.6 mH	402 µH/Ω

Modul 9203B2A Terminal 41-43			Co	Lo	Lo/Ro
Uo	28 V	IIC			
Io	125 mA	IIB	640 nF	9.1 mH	162 µH/Ω
Po	0.88 W	IIA	2.1 µF	17.6 mH	325 µH/Ω

Modul 9203B1A & 9203B1B Terminal 41-44 / 51-54			Co	Lo	Lo/Ro
Uo	28 V	IIC	80 nF	2.9 mH	46 µH/Ω
Io	110 mA	IIB	640 nF	11.8 mH	184 µH/Ω
Po	0.77 W	IIA	2.1 µF	22.8 mH	369 µH/Ω

Modul 9203B2A Terminal 41-44			Co	Lo	Lo/Ro
Uo	28 V	IIC			
Io	135 mA	IIB	640 nF	7.8 mH	150 µH/Ω
Po	0.95 W	IIA	2.1 µF	15.1 mH	301 µH/Ω

**Terminal (31,32)**
**Supply:**

Voltage	19.2 – 31.2 VDC
Power max.	3.5 W

**Terminal (11,12 and 13,14)**
**Input:**

Voltage	max. 28 VDC
Trig: NPN	Low < 2 V, High > 4 V
Trig: PNP	Low < 8 V, High > 10 V

**Terminal (33,34)**
**Status Relay:**

<b>Non Hazardous location</b>	
Voltage max.	125 VAC / 110 VDC
Power max.	62.5 VA / 32 W
Current max.	0.5 AAC / 0.3 ADC

**Zone 2 installation**

32 VAC / 32 VDC
16 VA / 32 W
0.5 AAC / 1 ADC

**Installation notes.**

For installation in Zone 2, the module must be installed in an outer enclosure having an IP protection of at least IP54 according to type of protection Ex-n or Ex-e.

For installation on Power Rail in Zone 2, only Power Rail type 9400 supplied by Power Control Unit type 9410 is allowed.

In type of protection "intrinsic safety iD" the parameters for intrinsic safety for gas group IIB are applicable.

If the sensor circuits (Terminals 41...44, 51...54) have been installed in a type of protection other than "intrinsic safety", the module shall not be re-installed in type of protection "intrinsic safety".

Do not separate connectors when energized and an explosive gas mixture is present.

Do not mount or remove modules from the Power Rail when an explosive gas mixture is present.

The maximum internal Power dissipation for adjacent modules is assumed to be max. 2 W each.

## ATEX Installation drawing

**9203**

For safe installation of 9203B the following must be observed. The module shall only be installed by qualified personnel who are familiar with the national and international laws, directives and standards that apply to this area.

Year of manufacture can be taken from the first two digits in the serial number.

**4501**

For Installation in Zone 2 / Division 2 the following must be observed.

The 4501 programming module is to be used solely with PRElectronics modules. It is important that the module is undamaged and has not been altered or modified in any way. Only 4501 modules free of dust and moisture shall be installed.

ATEX Certificate      KEMA 07ATEX 0147 X

Marking



II 3 G Ex nA nC IIC/IIB/IIA T4  
II (1) G [Ex ia] IIC/IIB/IIA  
II (1) D [Ex iaD]

Standards

EN 60079-0 : 2006, EN 60079-11 : 2007, EN 60079-15 : 2005  
EN 60079-26 : 2007, EN 61241-0 : 2006, EN 61241-11 : 2006

Hazardous area  
Zone 0,1,2, 20, 21, 22

Non Hazardous Area  
or Zone 2

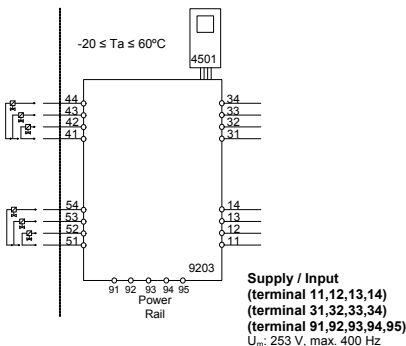

Modul 9203B1A & 9203B1B Terminal 41-42 / 51-52			Co	Lo	Lo/Ro
Uo	28 V	IIC	80 nF	4.2 mH	54 µH/Ω
Io	93 mA	IIB	640 nF	16.8 mH	218 µH/Ω
Po	0.65 W	IIA	2.1 µF	32.6 mH	436 µH/Ω

Modul 9203B2A Terminal 41-42			Co	Lo	Lo/Ro
Uo	28 V	IIC	80 nF	2.69 mH	44 µH/Ω
Io	115 mA	IIB	640 nF	10.8 mH	176 µH/Ω
Po	0.81 W	IIA	2.1 µF	20.8 mH	353 µH/Ω

Modul 9203B1A & 9203B1B Terminal 41-43 / 51-53			Co	Lo	Lo/Ro
Uo	28 V	IIC	80 nF	3.5 mH	50 µH/Ω
Io	100 mA	IIB	640 nF	14.2 mH	201 µH/Ω
Po	0.70 W	IIA	2.1 µF	27.6 mH	402 µH/Ω

Modul 9203B2A Terminal 41-43			Co	Lo	Lo/Ro
Uo	28 V	IIC			
Io	125 mA	IIB	640 nF	9.1 mH	162 µH/Ω
Po	0.88 W	IIA	2.1 µF	17.6 mH	325 µH/Ω

Modul 9203B1A & 9203B1B Terminal 41-44 / 51-54			Co	Lo	Lo/Ro
Uo	28 V	IIC	80 nF	2.9 mH	46 µH/Ω
Io	110 mA	IIB	640 nF	11.8 mH	184 µH/Ω
Po	0.77 W	IIA	2.1 µF	22.8 mH	369 µH/Ω

Modul 9203B2A Terminal 41-44			Co	Lo	Lo/Ro
Uo	28 V	IIC			
Io	135 mA	IIB	640 nF	7.8 mH	150 µH/Ω
Po	0.95 W	IIA	2.1 µF	15.1 mH	301 µH/Ω

**Terminal (31,32)**
**Supply:**

Voltage	19.2 – 31.2 VDC
Power max.	3.5 W

**Terminal (11,12 and 13,14)**
**Input:**

Voltage	max 28 VDC
Trig: NPN	Low < 2 V, High > 4 V
Trig: PNP	Low < 8 V, High > 10 V

**Terminal (33,34)**
**Status Relay:**

Voltage max.	125 VAC / 110 VDC
Power max.	62.5 VA / 32 W
Current max.	0.5 AAC / 0.3 ADC

**Zone 2 Installation**

Voltage max.	32 VAC / 32 VDC
Power max.	16 VA / 32 W
Current max.	0.5 AAC / 1 ADC

**Installation notes.**

For installation in Zone 2, the module must be installed in an outer enclosure having an IP protection of at least IP54, according to type of protection Ex-n or Ex-e.

For installation on Power Rail in Zone 2, only Power Rail type 9400 supplied by Power Control Unit type 9410 is allowed.

In type of protection "intrinsic safety iD" the parameters for intrinsic safety for gas group IIB are applicable.

After the sensor circuits (Terminals 41...44, 51...54) have been installed in a type of protection other than "intrinsic safety", the module shall not be re-installed in type of protection "intrinsic safety". Do not separate connectors when energized and an explosive gas mixture is present.

Do not mount or remove modules from the Power Rail when an explosive gas mixture is present. The maximum internal Power dissipation for adjacent modules is assumed to be max. 2 W each.

## Schéma d'installation ATEX

**9203**

Pour une installation sûre du 9203B vous devez observer ce qui suit. Le module sera seulement installé par un personnel qualifié qui est informé des lois, des directives et des normes nationales et internationales qui s'appliquent à ce secteur. L'année de la fabrication est indiquée dans les deux premiers chiffres dans le numéro de série.

**4501**

Pour l'installation dans la zone 2 / Division 2 on doit observer ce qui suit.

Le module de programmation 4501 doit être employé seulement avec des modules de PR electronics. Il est important que le module soit intact et n'ait pas été changé ou n'ait pas été modifié de quelque façon que se soit. Le module 4501 doit être exempt des zones de poussières et d'humidité lorsqu'il est installé.

Certificat ATEX      KEMA 07ATEX 0147 X

Marquage



II 3 G Ex nA nC IIC/IIB/IIA T4  
II (1) G [Ex ia] IIC/IIB/IIA  
II (1) D [Ex iaD]

Standards

EN 60079-0 : 2006, EN 60079-11 : 2007, EN 60079-15 : 2005  
EN 60079-26 : 2007, EN 61241-0 : 2006, EN 61241-11 : 2006

Zone dangereuse  
Zone 0,1,2, 20, 21, 22

Zone non dangereuse ou  
Zone 2

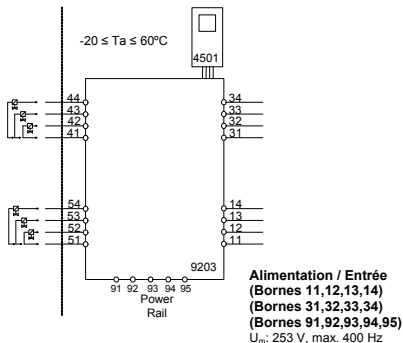

Modul 9203B1A & 9203B1B Terminal 41-42 / 51-52			Co	Lo	Lo/Ro
Uo	28 V	IIC	80 nF	4.2 mH	54 µH/Ω
Io	93 mA	IIB	640 nF	16.8 mH	218 µH/Ω
Po	0.65 W	IIA	2.1 µF	32.6 mH	436 µH/Ω

Modul 9203B2A Terminal 41-42			Co	Lo	Lo/Ro
Uo	28 V	IIC	80 nF	2.69 mH	44 µH/Ω
Io	115 mA	IIB	640 nF	10.8 mH	176 µH/Ω
Po	0.81 W	IIA	2.1 µF	20.8 mH	353 µH/Ω

Modul 9203B1A & 9203B1B Terminal 41-43 / 51-53			Co	Lo	Lo/Ro
Uo	28 V	IIC	80 nF	3.5 mH	50 µH/Ω
Io	100 mA	IIB	640 nF	14.2 mH	201 µH/Ω
Po	0.70 W	IIA	2.1 µF	27.6 mH	402 µH/Ω

Modul 9203B2A Terminal 41-43			Co	Lo	Lo/Ro
Uo	28 V	IIC			
Io	125 mA	IIB	640 nF	9.1 mH	162 µH/Ω
Po	0.88 W	IIA	2.1 µF	17.6 mH	325 µH/Ω

Modul 9203B1A & 9203B1B Terminal 41-44 / 51-54			Co	Lo	Lo/Ro
Uo	28 V	IIC	80 nF	2.9 mH	46 µH/Ω
Io	110 mA	IIB	640 nF	11.8 mH	184 µH/Ω
Po	0.77 W	IIA	2.1 µF	22.8 mH	369 µH/Ω

Modul 9203B2A Terminal 41-44			Co	Lo	Lo/Ro
Uo	28 V	IIC			
Io	135 mA	IIB	640 nF	7.8 mH	150 µH/Ω
Po	0.95 W	IIA	2.1 µF	15.1 mH	301 µH/Ω

**Bornes (31,32)**
**Alimentation :**

Tension 19,2 – 31,2 Vcc  
Puissance max. 3,5 W

**Bornes (11,12 et 13,14)**
**Entrée :**

Tension Max. 28 Vcc  
Déclenchement : NPN Bas < 2 V, Haut > 4 V  
Déclenchement : PNP Bas < 8 V, Haut > 10 V

**Bornes (33,34)**
**Relais d'état :**

Tension max. 125 Vca / 110 Vcc  
Puissance max. 62,5 VA / 32 W  
Courant max. 0,5 Aca / 0,3 Acc

**Localisation zone non dangereuse**
**Installation en Zone 2**

32 Vca / 32 Vcc  
16 VA / 32 W  
0,5 Aca / 1 Acc

**Notes d'installation :**

Pour l'installation dans la zone 2, le module doit être installé dans une enceinte externe ayant une protection d'étanchéité au moins d'IP54, selon le type de protection Ex-n ou Ex-e.

Pour l'installation avec le rail d'alimentation dans la zone 2, on doit utiliser seulement le bloc d'alimentation du rail type 9400 ainsi que le contrôleur de puissance type 9410.

Selon le type de protection « sécurité intrinsèque iD » les paramètres pour la sécurité intrinsèque pour le gaz IIB s'appliquent.

Après les circuits de sonde (bornes 41..44, 51..54) ont été installés dans les autres types de protection autre que « la sécurité intrinsèque », le module ne peut pas être réinstallé dans le type de protection « sécurité intrinsèque ».

Ne déconnecter pas les connecteurs une fois activé et dans un environnement en présence de gaz. La dissipation de puissance admissible pour les modules avoisinants est présumée d'être de 2 W pour chaque module.

## Installationszeichnung

**9203**

Für die sichere Installation von 9203B ist Folgendes zu beachten: Das Gerät darf nur von qualifiziertem Personal eingebaut werden, das mit den nationalen und internationalen Gesetzen, Richtlinien und Standards auf diesem Gebiet vertraut ist. Das Baujahr kann aus den ersten beiden Ziffern der Seriennummer ersehen werden.

**4501**

Für die Installation in Zone 2 / Division 2 ist Folgendes zu beachten: Das aufsteckbare Frontdisplay 4501 zur Programmierung ist ausschließlich mit PR electronics-Geräten zu verwenden. Es ist wichtig, dass das Display unbeschädigt ist, nicht umgebaut oder in irgendeiner Weise verändert wurde. Das 4501 darf nur frei von Staub und Feuchtigkeit installiert werden.

ATEX-Zertifikat KEMA 07ATEX 0147 X

**Markierung**

II 3 G Ex nA nC IIC/IIB/IIA T4

II (1) G [Ex ia] IIC/IIB/IIA

II (1) D [Ex iaD]

**Normen**

EN 60079-0 : 2006, EN 60079-11 : 2007, EN 60079-15 : 2005

EN 60079-26 : 2007, EN 61241-0 : 2006, EN 61241-11 : 2006

Ex-Bereich  
Zone 0,1,2, 20, 21, 22

Nicht Ex-Bereich oder  
Zone 2

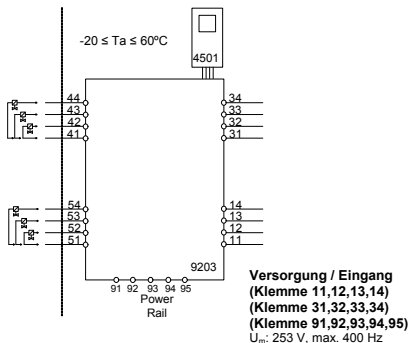

Modul 9203B1A & 9203B1B Terminal 41-42 / 51-52			Co	Lo	Lo/Ro
Uo	28 V	IIC	80 nF	4.2 mH	54 µH/Ω
Io	93 mA	IIB	640 nF	16.8 mH	218 µH/Ω
Po	0.65 W	IIA	2.1 µF	32.6 mH	436 µH/Ω

Modul 9203B2A Terminal 41-42			Co	Lo	Lo/Ro
Uo	28 V	IIC	80 nF	2.69 mH	44 µH/Ω
Io	115 mA	IIB	640 nF	10.8 mH	176 µH/Ω
Po	0.81 W	IIA	2.1 µF	20.8 mH	353 µH/Ω

Modul 9203B1A & 9203B1B Terminal 41-43 / 51-53			Co	Lo	Lo/Ro
Uo	28 V	IIC	80 nF	3.5 mH	50 µH/Ω
Io	100 mA	IIB	640 nF	14.2 mH	201 µH/Ω
Po	0.70 W	IIA	2.1 µF	27.6 mH	402 µH/Ω

Modul 9203B2A Terminal 41-43			Co	Lo	Lo/Ro
Uo	28 V	IIC			
Io	125 mA	IIB	640 nF	9.1 mH	162 µH/Ω
Po	0.88 W	IIA	2.1 µF	17.6 mH	325 µH/Ω

Modul 9203B1A & 9203B1B Terminal 41-44 / 51-54			Co	Lo	Lo/Ro
Uo	28 V	IIC	80 nF	2.9 mH	46 µH/Ω
Io	110 mA	IIB	640 nF	11.8 mH	184 µH/Ω
Po	0.77 W	IIA	2.1 µF	22.8 mH	369 µH/Ω

Modul 9203B2A Terminal 41-44			Co	Lo	Lo/Ro
Uo	28 V	IIC			
Io	135 mA	IIB	640 nF	7.8 mH	150 µH/Ω
Po	0.95 W	IIA	2.1 µF	15.1 mH	301 µH/Ω

**Klemme (31,32)**
**Versorgung:**

Spannung	19,2 – 31,2 VDC
Leistung max.	3,5 W

**Klemme (11,12 und 13,14)**
**Eingang:**

Spannung	max. 28 VDC
Trig: NPN	Low < 2 V, High > 4 V
Trig: PNP	Low < 8 V, High > 10 V

**Klemme (33,34)**
**Statusrelais:**

Spannung max.	<b>Nicht explosionsgefährdeter Bereich</b> 125 VAC / 110 VDC
Leistung max.	62,5 VA / 32 W
Strom max.	0,5 AAC / 0,3 ADC

**Zone 2-Installation**

	32 VAC / 32 VDC
	16 VA / 32 W
	0,5 AAC / 1 ADC

**Installationsvorschriften:**

Für die Installation in Zone 2 muss das Gerät in einem Gehäuse der IP-Schutzart von mindestens IP54 bzw. je nach Art des Schutzes Ex-n oder Ex-e entsprechend eingebaut werden.

Für die Installation auf Power Rail in Zone 2 ist nur Power Rail Typ 9400 – in Verbindung mit dem Power Control Unit Typ 9410 - erlaubt.

Bei der Schutzart "Eigensicherheit iD" gelten die Parameter für die Eigensicherheit der Gas-Gruppe IIB.

Sind die Fühlerkreisläufe (Klemmen 41...44, 51...54) erst einmal in einer anderen Schutzart als "Eigensicherheit" installiert worden, darf das Gerät nach einem evtl. Ausbau nicht mit Schutzart "Eigensicherheit" wieder eingebaut werden.

Nicht die Anschlüsse trennen, solange ein Energiegeladenes explosives Gasgemisch vorhanden ist. Eine maximale Verlustleistung von 2 W für jedes Nachbargerät ist angenommen.

## ATEX Installationstegning

**9203**

For sikker installation af 9203B skal følgende overholdes: Modulet må kun installeres af kvalificerede personer, som er bekendt med national og international lovgivning, direktiver og standarder i det land, hvor modulet skal installeres. Produktionsår fremgår af de to første cifre i serienummeret.

**4501**

For installation i zone 2 skal følgende overholdes:

Den aftagelige displayfront til programmering 4501 er udelukkende beregnet til brug på PR electronics moduler. Det er vigtigt, at displayet er ubeskadiget, ikke ombygget eller på anden måde forandret. 4501 må kun anvendes, hvis det er fri for støv og/eller fugt.

ATEX-certifikat    KEMA 07ATEX 0147 X

Mærkning



II 3 G Ex nA nC IIC/IIB/IIA T4  
 II (1) G [Ex ia] IIC/IIB/IIA  
 II (1) D [Ex iaD]

Standarder

EN 60079-0 : 2006, EN 60079-11 : 2007, EN 60079-15 : 2005  
 EN 60079-26 : 2007, EN 61241-0 : 2006, EN 61241-11 : 2006

Ex-område  
 Zone 0,1,2, 20, 21, 22

Ikke Ex-område eller  
 Zone 2

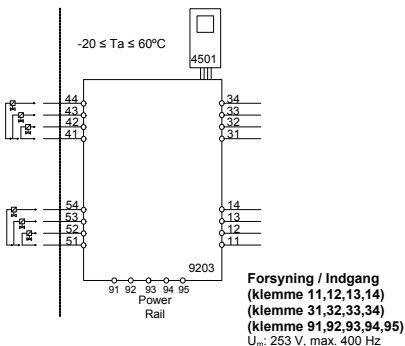

Modul 9203B1A & 9203B1B Terminal 41-42 / 51-52			Co	Lo	Lo/Ro
Uo	28 V	IIC	80 nF	4.2 mH	54 µH/Ω
Io	93 mA	IIB	640 nF	16.8 mH	218 µH/Ω
Po	0.65 W	IIA	2.1 µF	32.6 mH	436 µH/Ω

Modul 9203B2A Terminal 41-42			Co	Lo	Lo/Ro
Uo	28 V	IIC	80 nF	2.69 mH	44 µH/Ω
Io	115 mA	IIB	640 nF	10.8 mH	176 µH/Ω
Po	0.81 W	IIA	2.1 µF	20.8 mH	353 µH/Ω

Modul 9203B1A & 9203B1B Terminal 41-43 / 51-53			Co	Lo	Lo/Ro
Uo	28 V	IIC	80 nF	3.5 mH	50 µH/Ω
Io	100 mA	IIB	640 nF	14.2 mH	201 µH/Ω
Po	0.70 W	IIA	2.1 µF	27.6 mH	402 µH/Ω

Modul 9203B2A Terminal 41-43			Co	Lo	Lo/Ro
Uo	28 V	IIC			
Io	125 mA	IIB	640 nF	9.1 mH	162 µH/Ω
Po	0.88 W	IIA	2.1 µF	17.6 mH	325 µH/Ω

Modul 9203B1A & 9203B1B Terminal 41-44 / 51-54			Co	Lo	Lo/Ro
Uo	28 V	IIC	80 nF	2.9 mH	46 µH/Ω
Io	110 mA	IIB	640 nF	11.8 mH	184 µH/Ω
Po	0.77 W	IIA	2.1 µF	22.8 mH	369 µH/Ω

Modul 9203B2A Terminal 41-44			Co	Lo	Lo/Ro
Uo	28 V	IIC			
Io	135 mA	IIB	640 nF	7.8 mH	150 µH/Ω
Po	0.95 W	IIA	2.1 µF	15.1 mH	301 µH/Ω

**Klemme (31,32)**
**Forsyning:**

Spænding 19,2 – 31,2 VDC  
Effekt max. 3,5 W

**Klemme (11,12 og 13,14)**
**Indgang:**

Spænding max. 28 VDC  
Trig: NPN Low < 2 V, High > 4 V  
Trig: PNP Low < 8 V, High > 10 V

**Klemme (33,34)**
**Statusrelæ:**

Spænding max. 125 VAC / 110 VDC  
Effekt max. 62,5 VA / 32 W  
Strøm max. 0,5 AAC / 0,3 ADC

**Ikke-eksplosionsfarligt område**
**Zone 2-Installation**

32 VAC / 32 VDC  
16 VA / 32 W  
0,5 AAC / 1 ADC

**Installationsforskrifter**

For installation i zone 2 skal modulet installeres i et hus, som har en IP-beskyttelse på mindst IP54 i henhold til beskyttelsestype Ex-n eller Ex-e.

Ved installation på Power Rail type 9400 i zone 2 er det kun tilladt at forsyne Power Rail ved brug af 9410 Power Control Unit.

Ved beskyttelsesmetode „egensikker iD“ er parametrene for egensikker gasgruppe IIB gældende.

Har sensorkredsløb (klemme 41...44, 51...54) først en gang været installeret som en anden beskyttelsesmetode end "egensikker", må modulet ikke geninstalleres som beskyttelsesmetode egensikker.

Monter/demonter ikke stik, når forsyning er tilsluttet og der forefindes en eksplosionsfarlig gasblanding.

Det maksimale interne effekttab for nabomoduler antages at være max. 2 W hver.

## FM Installation drawing

**9203**

For safe installation of 9203B the following must be observed. The module shall only be installed by qualified personnel who are familiar with the national and international laws, directives and standards that apply to this area.

Year of manufacture can be taken from the first two digits in the serial number.

**4501**

For Installation in Zone 2 / Division 2 the following must be observed.

The 4501 programming module is to be used solely with PR electronics modules. It is important that the module is not damaged and has not been altered or modified in any way. Only 4501 modules free of dust and moisture shall be installed.

c-FM-us Certificate

3035277

**Hazardous area**

Class I/II/III, Division 1, Group A,B,C,D,E,F,G  
or Class I, Zone 0/1 Group IIC, [AEx ia] IIC or  
or Class I, Zone 0/1 Group IIC, [Ex ia] IIC

**Non Hazardous Area or**

Class I, Division 2, Group A,B,C,D T4  
or Class I, Zone 2 Group IIC T4

Simple Apparatus or  
Intrinsically safe apparatus  
with entity parameters:

$$V_{max}(U_i) \geq V_t(U_o)$$

$$I_{max}(I_i) \geq I_t(I_o)$$

$$P_i \geq P_t(P_o)$$

$$C_a(C_o) \geq C_{cable} + C_i$$

$$L_a(L_o) \geq L_{cable} + L_i$$

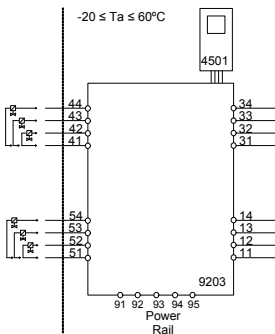
**Supply / Input**

(terminal 11,12,13,14)

(terminal 31,32,33,34)

(terminal 91,92,93,94,95)

$U_m$ : 253 V, max. 400 Hz

LERBAKKEN 10, 8410 RØNDE DENMARK

Modul 9203B1A & 9203B1B Terminal 41-42 / 51-52			Co/Ca	Lo/La	Lo/Ro or La/Ra
Uo/Voc	28 V	IIC or A.B	80 nF	4.2 mH	54 µH/Ω
Io/Isc	93 mA	IIB or C.E.F	640 nF	16.8 mH	218 µH/Ω
Po	0.65 W	IIA or D.G	2.1 µF	32.6 mH	436 µH/Ω

Modul 9203B2A Terminal 41-42			Co/Ca	Lo/La	Lo/Ro or La/Ra
Uo/Voc	28 V	IIC or A.B	80 nF	2.69 mH	44 µH/Ω
Io/Isc	115 mA	IIB or C.E.F	640 nF	10.8 mH	176 µH/Ω
Po	0.81 W	IIA or D.G	2.1 µF	20.8 mH	353 µH/Ω

Modul 9203B1A & 9203B1B Terminal 41-43 / 51-53			Co/Ca	Lo/La	Lo/Ro or La/Ra
Uo/Voc	28 V	IIC or A.B	80 nF	3.5 mH	50 µH/Ω
Io/Isc	100 mA	IIB or C.E.F	640 nF	14.2 mH	201 µH/Ω
Po	0.70 W	IIA or D.G	2.1 µF	27.6 mH	402 µH/Ω

Modul 9203B2A Terminal 41-43			Co/Ca	Lo/La	Lo/Ro or La/Ra
Uo/Voc	28 V	IIC or A.B	640 nF	9.1 mH	162 µH/Ω
Io/Isc	125 mA	IIB or C.E.F	640 nF	17.6 mH	325 µH/Ω
Po	0.88 W	IIA or D.G	2.1 µF	17.6 mH	325 µH/Ω

Modul 9203B1A & 9203B1B Terminal 41-44 / 51-54			Co/Ca	Lo/La	Lo/Ro or La/Ra
Uo/Voc	28 V	IIC or A.B	80 nF	2.9 mH	46 µH/Ω
Io/Isc	110 mA	IIB or C.E.F	640 nF	11.8 mH	184 µH/Ω
Po	0.77 W	IIA or D.G	2.1 µF	22.8 mH	369 µH/Ω

Modul 9203B2A Terminal 41-44			Co/Ca	Lo/La	Lo/Ro or La/Ra
Uo/Voc	28 V	IIC or A.B	640 nF	7.8 mH	150 µH/Ω
Io/Isc	135 mA	IIB or C.E.F	640 nF	15.1 mH	301 µH/Ω
Po	0.95 W	IIA or D.G	2.1 µF	15.1 mH	301 µH/Ω

**Terminal (31,32)**
**Supply:**

Voltage	19.2 – 31.2 VDC
Power max.	3.5 W

**Terminal (11,12 and 13,14)**
**Input:**

Voltage	max. 28 VDC
Trig: NPN	Low < 2 V, High > 4 V
Trig: PNP	Low < 8 V, High > 10 V

**Terminal (33,34)**
**Status Relay:**

Voltage max.	125 VAC / 110 VDC
Power max.	62.5 VA / 32 W
Current max.	0.5 AAC / 0.3 ADC

**Non Hazardous location:**
**Division 2 or Zone 2 installation:**

Voltage max.	32 VAC / 32 VDC
Power max.	16 VA / 32 W
Current max.	0.5 AAC / 1 ADC

**Installation notes:**

The installation and wiring shall be in accordance with the Canadian Electrical Code for Canada and National Electrical Code NFPA 70, Article 500 or 505 for installation in USA.

The module must be supplied from a Power Supply having double or reinforced insulation.

The use of stranded wires is not permitted for mains wiring except when wires are fitted with cable ends.

For installation on the 9400 Power Rail the power must be supplied from Power Control Module Unit 9410.

The module must be installed in pollution degree 2 or better.

The module must be installed in an enclosure suitable for the environment for which it is used.

For installation in Zone 2 or Division 2, the module must be installed in a suitable outer enclosure according to the regulations in the CEC for Canada or NEC for USA.

The module is galvanically isolated and does not require grounding.

Use 60 / 75 °C copper conductors with wire size AWG: (26-14).

The maximum internal Power dissipation of adjacent modules is assumed to be max. 2 W each.

**Warning:** Substitution of components may impair intrinsic safety and / or suitability for Div. 2 / Zone 2.

**Warning:** To prevent ignition of explosive atmospheres, disconnect power before servicing and do not separate connectors when energized and an explosive gas mixture is present.

**Warning:** Do not mount or remove modules from the Power Rail when an explosive gas mixture is present.

# **SAFETY MANUAL**

## **SOLENOID / ALARM DRIVER**

**9203**

**This safety manual is valid for the following product versions:**

**9203-001**

## 0. CONTENTS

1. Observed standards .....	2
2. Acronyms and abbreviations .....	2
3. Purpose of the product .....	3
4. Assumptions and restrictions for use of the product.....	3
4.1 Basic safety specifications .....	3
4.2 Associated equipment.....	3
4.2.1 Safety output.....	3
4.2.2 Safety input.....	3
4.3 Failure rates .....	3
4.4 Safe parameterisation.....	4
4.5 Installation in hazardous areas .....	4
5. Functional specification of the safety functions.....	4
6. Functional specification of the non-safety functions .....	4
7. Safety parameters .....	4
8. Hardware and software configuration .....	5
9. Failure category.....	5
10. Periodic proof test procedure .....	5
11. Procedures to repair or replace the product.....	5
12. Maintenance.....	5
13. Documentation for routing diagram .....	6
13.1 In general .....	6
13.2 Further explanations .....	6
13.2.1 Password protection .....	6
13.4 Advanced functions .....	6
13.4.1 Display setup .....	7
13.4.2 Password .....	7
13.4.3 Language .....	7
13.4.4 Power rail .....	7
13.4.5 Safety integrity level.....	7
14 Safe parameterisation - user responsibility.....	8
14.1 Safety-related configuration parameters.....	8
14.2 Verification procedure.....	8
14.2.1 If no password is set.....	8
14.2.2 If password is set.....	9
14.3 Functional test .....	9
15. Fault reaction and restart condition .....	9
16 User interface .....	10
16.1 Scrolling help texts in display line 3 .....	10
16.3 Routing diagram - Advanced settings (ADV.SET).....	12
17 Connections diagram .....	13

## 1. Observed standards

Standard	Description
IEC 61508	Functional Safety of electrical / electronic / programmable electronic safety-related systems
IEC 61508-2:2000	Part 2: Requirements for electrical / electronic / programmable electronic safety-related systems
IEC 61508-3:1998	Part 3: Software requirements
IEC 61326-3-1:2008	Immunity requirements for safety-related systems

## 2. Acronyms and abbreviations

Acronym / Abbreviation	Designation	Description
Element		Term defined by IEC 61508 as “part of a subsystem comprising a single component or any group of components that performs one or more element safety functions”
PFD	Probability of Failure on Demand	This is the likelihood of dangerous safety function failures occurring on demand.
PFH	Probability of dangerous Failure per Hour	The term “Probability” is misleading, as IEC 61508 defines a Rate.
SFF	Safe Failure Fraction	Safe Failure Fraction summarises the fraction of failures which lead to a safe state and the fraction of failures which will be detected by diagnostic measures and lead to a defined safety action.
SIF	Safety Integrity Function	Function that provides fault detection (to ensure the necessary safety integrity for the safety functions)
SIL	Safety Integrity Level	The international standard IEC 61508 specifies four discrete safety integrity levels (SIL 1 to SIL 4). Each level corresponds to a specific probability range regarding the failure of a safety function.

### 3. Purpose of the product

Universal Ex driver for the control of solenoids etc. with various Ex data by way of three built-in Ex barriers.

The device can be mounted in the safe area and in zone 2 / div. 2 and transmit signals to zone 0, 1, 2, 20, 21 and 22.

Ex driver for the control of ON / OFF solenoids, acoustic alarms and LEDs mounted in the hazardous area.

The 9203 is controlled by an NPN/PNP signal or a switch signal.

Monitoring of internal error events via the individual status relay and/or a collective electronic signal via the power rail.

The 9203 has been designed, developed and certified for use in SIL 2 applications according to the requirements of IEC 61508.

### 4. Assumptions and restrictions for use of the product

#### 4.1 Basic safety specifications

Operational temperature range .....	-20...+60°C
Storage temperature range .....	-20...+85°C
Power supply type, min.....	Double or reinforced
Supply voltage.....	19.2...31.2 VDC
Mounting area.....	Zone 2 / Division 2 or safe area
Mounting environment.....	Pollution degree 2 or better

#### 4.2 Associated equipment

##### 4.2.1 Safety output

The safety output shall be connected to the equipment with a minimum load of 10 K $\Omega$

##### 4.2.2 Safety input

The safety input signal frequency shall not be higher than 20 Hz, and the pulse length shall not be shorter than 25 ms.

#### 4.3 Failure rates

The basic failure rates from the Siemens standard SN 29500 are used as the failure rate database.

Failure rates are constant, wear-out mechanisms are not included.

External power supply failure rates are not included.

#### 4.4 Safe parameterisation

The user is responsible for verifying the correctness of the configuration parameters. (See section 14 Safe parameterisation - user responsibility). Manual override may not be used for safety applications.

#### 4.5 Installation in hazardous areas

The IECex Installation drawing, ATEX Installation drawing and FM Installation drawing shall be followed if the products are installed in hazardous areas.

### 5. Functional specification of the safety functions

Ex driver for the control of ON / OFF solenoids, acoustic alarms and LEDs mounted in the hazardous area.

### 6. Functional specification of the non-safety functions

The status relay (terminal 33 and 34), error signal on power rail (terminal 91) and LED outputs are not suitable for use in any Safety Instrumented Function.

### 7. Safety parameters

	B1A, B1B	B2A
Probability of dangerous Failure per Hour (PFH)	4.30E-08	4.60E-08
	Note <sup>1</sup>	
Probability of failure on demand (PFD) - 1 year proof test interval	2.73E-04	2.92E-04
Proof test interval (10% of loop PFD)	5 years	4 years
Safe Failure Fraction	91%	91%
Demand response time	<10 ms	
Demand mode	High	
Demand rate	1000 s	
Mean Time To Repair (MTTR)	24 hours	
Diagnostic test interval	10 seconds	
Hardware Fault Tolerance (HFT)	0	
Component Type	B	
SIL capability	SIL 2	
Description of the "Safe State"	De-energised	

Note<sup>1</sup>: The 9203 contains no lifetime limiting components, therefore the PFH figures are valid for up to 12 years, according to IEC 61508.

## 8. Hardware and software configuration

All configurations of software and hardware versions are fixed from factory, and cannot be changed by end-user or reseller.

This manual only covers products labelled with the product version (or range of versions) specified on the front page.

## 9. Failure category

Failure category	Failure rates (1/h)	
	B1A, B1B	B2A
Fail Safe Detected	0.00E+00	0.00E+00
Fail Safe Undetected	4.77E-07	4.80E-07
Fail Dangerous Detected	0.00E+00	0.00E+00
Fail Dangerous Undetected	4.30E-08	4.60E-08

## 10. Periodic proof test procedure

Step	Action
1	Bypass the safety PLC or take other appropriate action to avoid a false trip
2	Connect a simulator identical to the input setup
3	Perform an ON / OFF signal for each channel
4	Observe whether the output channel acts as expected
5	Restore the input terminals to full operation
6	Remove the bypass from the safety PLC or otherwise restore normal operation

This test will detect approximately 95% of possible “du” (dangerous undetected) failures in the device. The proof test is equivalent to the functional test.

## 11. Procedures to repair or replace the product

Any failures that are detected and that compromise functional safety should be reported to the sales department at PR electronics A/S.

Repair of the device and replacement of circuit breakers must be done by PR electronics A/S only.

## 12. Maintenance

No maintenance required.

## 13. Documentation for routing diagram

The routing diagram is shown in section 16.2.

### 13.1 In general

When configuring the 9203, you will be guided through all parameters and you can choose the settings which fit the application. For each menu there is a scrolling help text which is automatically shown in line 3 on the display.

Configuration is carried out by use of the 3 function keys:

- ⬆ will increase the numerical value or choose the next parameter
- ⬇ will decrease the numerical value or choose the previous parameter
- OK will accept the chosen value and proceed to the next menu

When configuration is completed, the display will return to the default state 1.0.

Pressing and holding OK will return to the previous menu or return to the default state (1.0) without saving the changed values or parameters.

If no key is activated for 1 minute, the display will return to the default state (1.0) without saving the changed values or parameters.

### 13.2 Further explanations

#### 13.2.1 Password protection

Access to the configuration can be blocked by assigning a password. The password is saved in the device in order to ensure a high degree of protection against unauthorised modifications to the configuration. Default password 2008 allows access to all configuration menus.

Password protection is mandatory in SIL applications.

### 13.4 Advanced functions

The unit gives access to a number of advanced functions which can be reached by answering “Yes” to the point “adv.set”.

**13.4.1 Display setup**

Here you can adjust the brightness contrast and the backlight. Setup of tag numbers with 5 alphanumerics. Selection of functional readout in line 2 and 3 of the display - choose between readout of digital output or tag no. When selecting "ALT" the readout toggles between digital output and tag no.

**13.4.2 Password**

Here you can choose a password between 0000 and 9999 in order to protect the device against unauthorised modifications to the configuration. The device is delivered default without password.

**13.4.3 Language**

In the menu "LANG" you can choose between 7 different language versions of help texts that will appear in the menu. You can choose between UK, DE, FR, IT, ES, SE and DK.

**13.4.4 Power rail**

In the menu "RAIL" you can choose if errors in the device are transmitted to the central surveillance in the PR 9410 power control unit.

**13.4.5 Safety integrity level**

See Safe parameterisation - user responsibility

## 14 Safe parameterisation - user responsibility

### 14.1 Safety-related configuration parameters

Parameters	Value	Description
CH1.FUN	DIR / INV	Direct / inverted channel function
CH2.FUN.	DIR / INV	Direct / inverted channel function
PASSW	0 - 9999	New password

The above safety-related configuration parameters are marked in red text in the routing diagrams and must be verified by the user in a SIL-configuration.

### 14.2 Verification procedure

The verification is done using the display / programming front PR 4501 by following the procedure described below.

#### 14.2.1 If no password is set

	Action	Display shows
1	Press OK	ADV.SET
2	Set (ADV.SET) to Yes and press OK	DISP SETUP
3	Step down to (SIL SETUP) and press OK	EN.SIL
4	Set (EN SIL) to YES and press OK	NEW.PASS
5	Set password to a number between 0 and 9999 and press OK (At this time the device starts operating in SIL mode with the entered configuration parameters!)	Verify⇒OPEN "briefly" ⇒LOCK*
6	Press OK to confirm verification of the OPEN-LOCK in the display	CH1.FUN
7	Verify Channel 1 function and press OK	CH2:FUN
8	Verify Channel 2 function and press OK	PASSW
9	Verify password and press OK	SIL.OK
10	Verify SIL and press OK	

\* Open is shown briefly in the display.

**14.2.2 If password is set**

	<b>Action</b>	<b>Display shows</b>
1	Press OK	PASSW
2	Enter password and press OK	ADV.SET
3	Set (ADV.SET) to Yes and press OK	DISP SETUP
4	Step down to (SIL SETUP) and press OK	EN.SIL
5	Set (EN SIL) to YES and press OK (At this time the device starts operating in SIL mode with the entered configuration parameters!)	Verify⇒OPEN "briefly" ⇒LOCK*
6	Press OK to confirm verification of the OPEN-LOCK in the display	CH1.FUN
7	Verify Channel 1 function and press OK	CH2:FUN
8	Verify Channel 2 function and press OK	PASSW
9	Verify password and press OK	SIL.OK
10	Verify SIL and press OK	

\* Open is shown briefly in the display

**14.3 Functional test**

The user is responsible for making a functional test after verification of safety parameters. The procedure for periodic proof test described in section 10 shall be used.

**15. Fault reaction and restart condition**

When the 9203 detects a fault the output will go to Safe State, in which the safety output will go to "de-energised".

For device faults there are 2 ways of bringing the device out of Safe State.

1. Power cycle the device.
2. Bring the device out of SIL mode (choose "NO" in the menu point "EN.SIL"), and set it back to SIL mode again (choose "YES" in the menu point "EN.SIL" and verify the configuration).

## 16 User interface

### 16.1 Scrolling help texts in display line 3

- [01] Set correct password
- [02] Enter advanced setup?
- [06] Enter language setup
  - Enter password setup
  - Enter display setup
  - Enter SIL setup
- [07] Select direct channel function
  - Select inverted channel function
- [09] Adjust LCD contrast
- [10] Adjust LCD backlight
- [11] Write a 5-character channel tag
- [12] Show output state in display
  - Show output load in display
  - Show tag in display
  - Alternate information shown in display
- [13] Configuration SIL status (Open / Locked)
- [14] Enable SIL configuration lock
- [15] Enable password protection?
- [16] Set new password
- [17] Select language
- [20] No communication - check connections
- [21] EProm error - check configuration
- [22] Hardware error

## ROUTING DIAGRAM

If no key is activated for 1 minute, the display will return to the default state 1.0 without saving configuration changes.

- ⤴ Increase value / choose next parameter
- ⤵ Decrease value / choose previous parameter
- ⊗ Accept the chosen value and proceed to the next menu
- Hold ⊗ Back to previous menu / return to menu 1.0 without saving

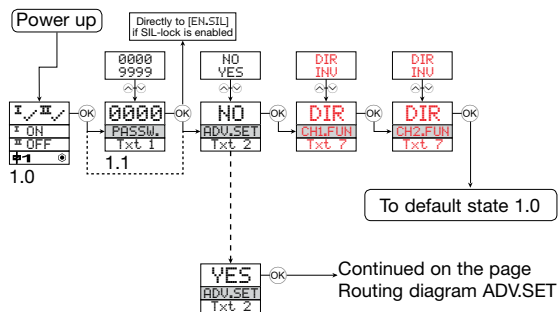

1.0 = Default state

Line 1 shows status for channel 1 and channel 2.

Line 2 shows output status for channel 1, output current or tag no.

Line 3 shows output status for channel 2, output current or tag no.

Line 4 indicates whether the module is SIL-locked.

1.1 = Only if password-protected.

1.2 If password has been set.

Line 1 symbols:

⊗ = OK. Flashing ⊗ = error.

Line 2 and 3 symbols:

⊗ ON = channel 1 ON

⊗ OFF = channel 2 OFF.

Line 4 symbols:

Static dot = SIL-locked.

Flashing dot = Not SIL-locked.

⊗ = output is active.

### 16.3 Routing diagram - Advanced settings (ADV.SET)

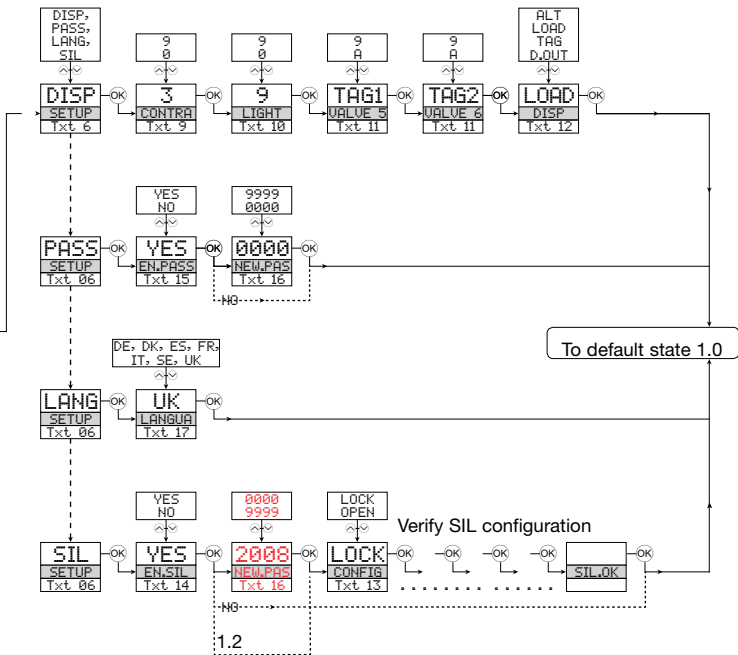

## 17 Connections diagram

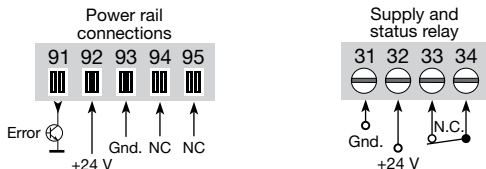

NC = No connection

### Inputs:

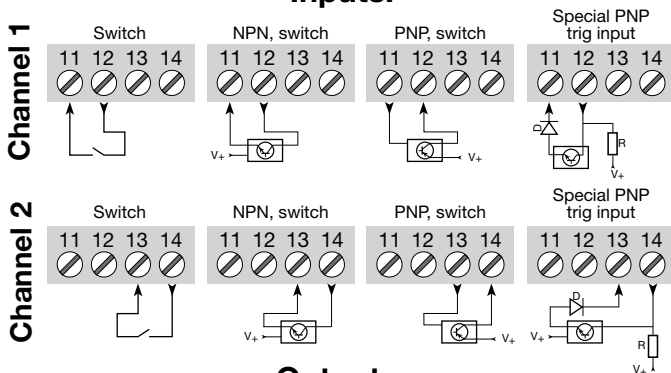

### Outputs:

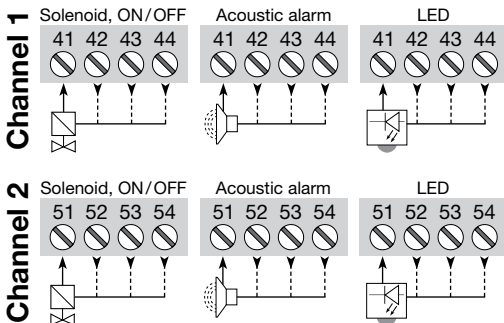



**Displays** Programmable displays with a wide selection of inputs and outputs for display of temperature, volume and weight, etc. Feature linearisation, scaling, and difference measurement functions for programming via PReset software.



**Ex interfaces** Interfaces for analogue and digital signals as well as HART® signals between sensors / I/P converters / frequency signals and control systems in Ex zone 0, 1 & 2 and for some modules in zone 20, 21 & 22.



**Isolation** Galvanic isolators for analogue and digital signals as well as HART® signals. A wide product range with both loop-powered and universal isolators featuring linearisation, inversion, and scaling of output signals.



**Temperature** A wide selection of transmitters for DIN form B mounting and DIN rail modules with analogue and digital bus communication ranging from application-specific to universal transmitters.



**Universal** PC or front programmable modules with universal options for input, output and supply. This range offers a number of advanced features such as process calibration, linearisation and auto-diagnosis.



## Subsidiaries

### France

PR electronics Sarl  
Zac du Chêne, Activillage  
4, allée des Sorbiers  
F-69673 Bron Cedex  
sales@preelectronics.fr  
tel. +33 (0) 4 72 14 06 07  
fax +33 (0) 4 72 37 88 20

### Germany

PR electronics GmbH  
Im Erlengrund 26  
D-46149 Oberhausen  
sales@preelectronics.de  
tel. +49 (0) 208 62 53 09-0  
fax +49 (0) 208 62 53 09-99

### Italy

PR electronics S.r.l.  
Via Giulietti 8  
IT-20132 Milano  
sales@preelectronics.it  
tel. +39 02 2630 6259  
fax +39 02 2630 6283

### Spain

PR electronics S.L.  
Avda. Meridiana 354, 9º B  
E-08027 Barcelona  
sales@preelectronics.es  
tel. +34 93 311 01 67  
fax +34 93 311 08 17

### Sweden

PR electronics AB  
August Barks gata 6A  
S-421 32 Västra Frölunda  
sales@preelectronics.se  
tel. +46 (0) 3149 9990  
fax +46 (0) 3149 1590

### UK

PR electronics UK Ltd  
Middle Barn, Apuldram  
Chichester  
West Sussex, PO20 7FD  
sales@preelectronics.co.uk  
tel. +44 (0) 1243 776 450  
fax +44 (0) 1243 774 065

### USA

PR electronics Inc  
11225 West Bernardo Court  
Suite A  
San Diego, California 92127  
sales@preelectronics.com  
tel. +1 858 521 0167  
fax +1 858 521 0945

## Head office

Denmark  
PR electronics A/S  
Lerbakken 10  
DK-8410 Rønne  
www.preelectronics.com  
sales@preelectronics.dk  
tel. +45 86 37 26 77  
fax +45 86 37 30 85

