

TEMPERATURE / mA CONVERTER



- Input for RTD, TC and mA
- Active / passive mA output
- 1 or 2 channels
- Can be supplied separately or installed on power rail, PR type 9400
- SIL 2-certified via Full Assessment



Advanced features:

- Configuration and monitoring by way of detachable display front (PR 4501); process calibration and signal simulation.
- Copying of the configuration from one device to others of the same type via the display front.
- TC inputs can use either the internal CJC or a terminal with a built-in Pt100 sensor (PR 5910Ex, channel 1 / PR 5913Ex, channel 2) for higher accuracy.
- The device automatically detects whether it must supply an active or a passive current signal.
- Advanced monitoring of internal communication and stored data.
- SIL 2 functionality is optional and must be activated in a menu point.

Application:

- The device can be mounted in the safe area and in zone 2 / div. 2 and receive signals from zone 0, 1, 2, 20, 21 and 22 / Class I/II/III, Div. 1, Gr. A-G.
- Conversion and scaling of temperature (Pt, Ni and TC) and active current signals.
- Monitoring of error events and cable breakage via the individual status relay and/or a collective electronic signal via the power rail.
- The 9113 has been designed, developed and certified for use in SIL 2 applications according to the requirements of IEC 61508.

Technical characteristics:

- 1 green and 2 red front LEDs indicate operation status and malfunction.
- 2.6 kVAC galvanic isolation between input, output and supply.

APPLICATIONS

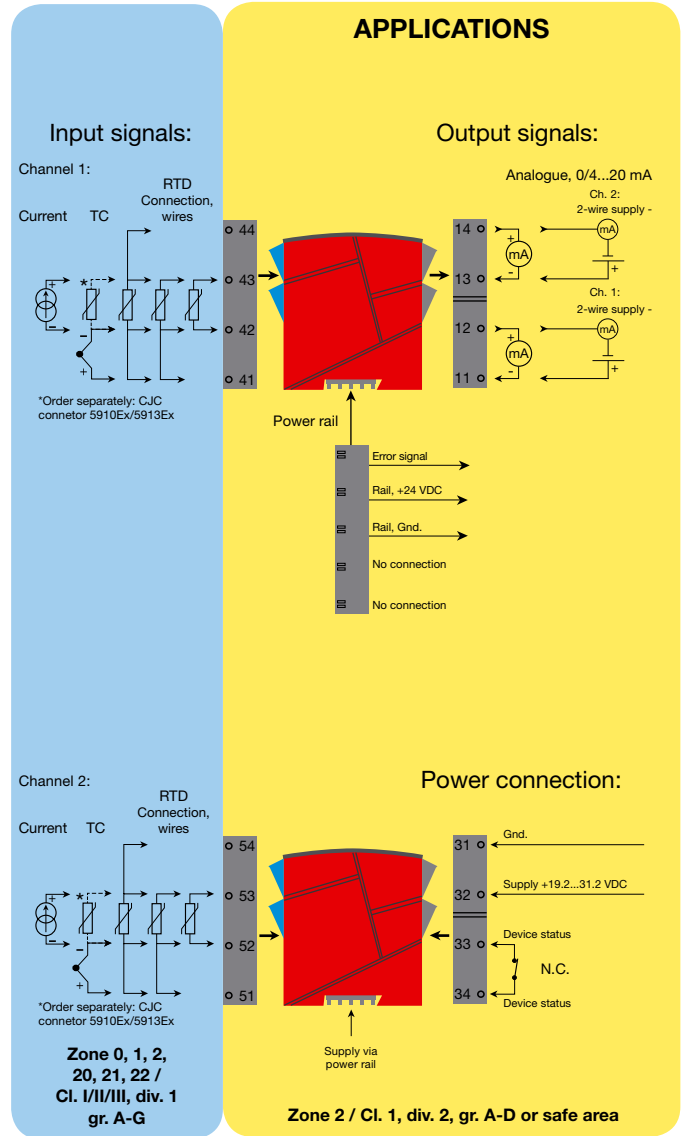

Type	Channels
9113B	Single: A Double: B

4501	= Display / programming front
5910Ex	= CJC connector, channel 1
5913Ex	= CJC connector, channel 2
9400	= Power rail



PR 4501 Display / programming front

Application:

- Communications interface for modification of operational parameters in 9113.
- Can be moved from one 9113 device to another and download the configuration of the first unit to subsequent units.
- When mounted in the process, the display shows process values and device status.

Technical characteristics:

- In order to protect the configuration against unauthorised changes, access to the menus can be blocked by a password.

Mounting / installation:

- Click 4501 onto the front of 9113.

Electrical specifications:

Specifications range..... -20°C to +60°C
Storage temperature..... -20°C to +85°C

Common specifications:

Supply voltage, DC 19.2...31.2 VDC
Max. consumption..... ≤ 3.5 W (2 channels)
Fuse..... 400 mA SB / 250 VAC

Isolation voltages, test / operation

Input / output / supply..... 2.6 kVAC / 250 VAC
Output 1 to output 2..... 1.5 kVAC / 150 VAC reinforced
Status relay to supply..... 1.5 kVAC / 150 VAC reinforced

Communications interface Programming front 4501
Signal / noise ratio..... Min. 60 dB (0...100 kHz)

Average response time incl. delay:

Temperature input ≤ 1 s
mA input ≤ 0.4 s
Calibration temperature..... 20...28°C

Accuracy, the greater of the general and basic values:

General values		
Input type	Absolute accuracy	Temperature coefficient
All	≤ ±0.1% of span	≤ ±0.01% of span / °C

Basic values		
Input type	Basic accuracy	Temperature coefficient
mA	≤ ±16 µA	≤ ±1.6 µA / °C
Pt100, Pt200, Pt 1000	≤ ±0.2°C	≤ ±0.02°C / °C
Pt500, Ni100, Ni120, Ni 1000	≤ ±0.3°C	≤ ±0.03°C / °C
Pt50, Pt400, Ni50	≤ ±0.4°C	≤ ±0.04°C / °C
Pt250, Pt300	≤ ±0.6°C	≤ ±0.06°C / °C
Pt20	≤ ±0.8°C	≤ ±0.08°C / °C
Pt10	≤ ±1.4°C	≤ ±0.14°C / °C
TC type:		
E, J, K, L, N, T, U	≤ ±1°C	≤ ±0.1°C / °C
R, S, W3, W5, LR	≤ ±2°C	≤ ±0.2°C / °C
B: 160...400°C	≤ ±4.5°C	≤ ±0.45°C / °C
B: 400...1820°C	≤ ±2°C	≤ ±0.2°C / °C

EMC immunity influence < ±0.5% of span
Extended EMC immunity:
NAMUR NE 21, A criterion, burst..... < ±1% of span

Wire size (min. / max.)..... 0,13...2,08 mm² / AWG 14...26 stranded wire

Relative humidity < 95% RH (non-cond.)
Protection degree..... IP20

Isolation:

Input to any 300 VAC double/reinforced
Analogue output to supply 300 VAC double/reinforced
Status relay to supply..... 150 VAC double/reinforced or 300 VAC basic

RTD input:

Input type	Min. value	Max. value	Standard
Pt100	-200°C	+850°C	IEC60751
Ni100	-60°C	+250°C	DIN 43760

Pt10*, Pt20*, Pt50*, Pt100, Pt200, Pt250, Pt300, Pt400, Pt500, Pt1000 Ni50, Ni100, Ni120, Ni1000

Cable resistance per wire (max.) 50 Ω
Sensor current..... Nom. 0.2 mA
Effect of sensor cable resistance (3- / 4-wire)..... < 0.002 Ω / Ω
Sensor error detection..... Programmable ON / OFF

TC input:

Thermocouple type B, E, J, K, L, N, R, S, T, U, W3, W5, LR

Cold junction compensation (CJC):

via ext. sensor in connector 5910... 20...28°C ≤ ±1°C
-20...20°C/28...70°C ≤ ±2°C
via internal sensor ±(2.0°C + 0.4°C * Δt)
Δt = internal temperature - ambient temperature

Sensor error detection..... Programmable ON or OFF (only wire breakage)

Sensor error current:

when detecting..... Nom. 2 µA
else..... 0 µA

Current input:

Programmable measurement ranges . 0...20 and 4...20 mA
Input resistance Nom. 20 Ω + PTC 50 Ω
Sensor error detection..... Programmable ON / OFF

Current output:

Signal range (span)..... 0...20 mA
Programmable signal ranges..... 0...20 / 4...20 / 20...0 and 20...4 mA

Load (max.)..... 20 mA / 600 Ω / 12 VDC
Load stability ≤ 0.01% of span / 100 Ω
Sensor error detection..... 0 / 3.5 / 23 mA / none
NAMUR NE 43 Upscale/Downscale.. 23 mA / 3.5 mA

Output limitation:

on 4...20 and 20...4 mA signals..... 3.8...20.5 mA
on 0...20 and 20...0 mA signals 0...20.5 mA
Current limit ≤ 28 mA

2-wire 4...20 mA output:

Load stability ≤ 0.01% of span / 100 Ω
Load resistance ≤ (V_{supply} -3.5)/0.023 A [Ω]
External 2-wire supply range..... 3.5...26 VDC

Status relay in safe area:

Max. voltage..... 125 VAC / 110 VDC
Max. current 0.5 AAC / 0.3 ADC
Max. AC power..... 62.5 VA / 32 W

Ex / I.S. approvals:

IECEx certificate KEM 09.0052 X
ATEX certificate KEMA 07ATEX0148 X
FM certificate..... 3038279 / 3038279C

Marine approval:

Det Norske Veritas, Ships & Offshore.. Pending

GOST R approval:

VNIIFTRI, Cert No. Pending

SIL certification:

exida, Cert No. PREI 070902 P0002 C03.01

Observed authority requirements: Standard:

EMC 2004/108/EC EN 61326-1
LVD 2006/95/EC EN 61010-1
ATEX 94/9/EC EN 60079-0, -11, -15, -26 and EN 61241-0, -11

IECEx IEC 60079-0, -11, -15, -26 IEC 61241-0 and -11

c FM us..... FM 3600, 3610, 3611, 3810 CAN/CSA E60079-0, -11

ANSI/ISA-12.00.01, -12.02.01, -82.02.01

ANSI/IEC-82.02.01

UL, Standard for Safety..... UL 61010-1

SIL..... IEC 61508

of span = of the currently selected measurement range

9000 EMC specifications - immunity :

Port	Phenomenon	Test standard	IEC 61326		NAMUR NE21 : 2007		IEC 61326-3-1		PR standard specifications		
			Test value	Criterion	Test value	Criterion	Test value for safety functions	Criterion	Test value	Criterion	
Enclosure	ESD input terminals	IEC 61000-4-2	4 kV Contact	B	6 kV Contact	B	6 kV Contact	6 kV Contact	FS	6 kV Contact	B
	ESD	IEC 61000-4-2	4 kV/8 kV Contact/Air	B	6 kV / 8 kV Contact / Air	A	6 kV / 8 kV Contact / Air	6 kV / 8 kV Contact / Air	FS	6 kV / 8 kV Contact / Air	A 1%
	HF field	IEC 61000-4-3	10 V/m, 80...1000 MHz 3 V/m, 1.4...2 GHz 1 V/m, 2...2.7 GHz	A	10 V/m, 80...1000 MHz 3...10 V/m, 1.4...2 GHz	A	20 V/m, 80...1000 MHz 10 V/m, 1.4...2 GHz 3 V/m, 2...2.7 GHz	20 V/m, 80...1000 MHz 10 V/m, 1.4...2 GHz 3 V/m, 2...2.7 GHz	FS	20 V/m, 80...1000 MHz 10 V/m, 1.4...2 GHz 3 V/m, 2...2.7 GHz	A 0.5%
	Magnetic field	IEC 61000-4-8	30 A/m	A	100 A/m	A	30 A/m	30 A/m	FS	30 A/m	A 0.5%
	Burst	IEC 61000-4-4	2 kV	B	2 kV	A	4 kV	4 kV	FS	4 kV	A 1.0%
	Surge	IEC 61000-4-5	1 kV / 2 kV, Diff. / Comm. 0 Ω/10 Ω	B	0.5 kV / 1 kV, Diff. / Comm. 0 Ω/10 Ω	A	1 kV / 2 kV, Diff. / Comm. 0 Ω/10 Ω	1 kV / 2 kV, Diff. / Comm. 0 Ω/10 Ω	FS	1 kV / 2 kV, Diff. / Comm. 0 Ω / 10 Ω	A 1.0%
	Conducted RF	IEC 61000-4-6	3 V, 150 kHz...80 MHz	A	10 V, 10 kHz...80 MHz Covers RF + LF	A	10 V, 150 kHz...80 MHz	10 V, 150 kHz...80 MHz	FS	10 V, 150 kHz...80 MHz	A 0.5%
	Interruptions	IEC 61000-4-29	60% for 10 ms 100% for 20 ms	B	100% for 20 ms	B	60% for 10 ms 100% for 20 ms	60% for 10 ms 100% for 20 ms	FS	60% for 10 ms 100% for 20 ms	B
I/O signal	Conducted LF	IEC 61000-4-16	Not required		Not required		1.5...15 kHz, 1...10 V 15...150 kHz, 10 V 50/60 Hz, 100 V	1.5...15 kHz, 1...10 V 15...150 kHz, 10 V 50/60 Hz, 100 V	FS	15 Hz...150 kHz, 10 V 50 Hz, 300 Ω, 230 V	A 0.5%
	Burst	IEC 61000-4-4	2 kV	B	2 kV	A	15...150 kHz, 10 V	15...150 kHz, 10 V	FS	2 kV	A 1.0%
	Surge input	IEC 61000-4-5	1 kV / 2 kV, Diff. / Comm. 40 Ω	B	0.5 kV / 1 kV, Diff. / Comm. 40 Ω	B	50/60 Hz, 100 V	50/60 Hz, 100 V	FS	1 kV / 2 kV Diff. / Comm. 40 Ω	B
	Surge output	IEC 61000-4-5	1 kV / 2 kV, Diff. / Comm. 40 Ω	B	0.5 kV / 1 kV, Diff. / Comm. 40 Ω	B	2 kV Comm. 40 Ω	2 kV Comm. 40 Ω	FS	1 kV / 2 kV Diff. / Comm. 40 Ω	A 1.0%
	Conducted RF	IEC 61000-4-6	3 V	A	10 V, 10 kHz...150 kHz	A	10 V, 150 kHz...80 MHz	10 V, 150 kHz...80 MHz	FS	10 V 150 kHz...100 MHz	A 0.5%
	Conducted LF	IEC 61000-4-16	Not required		Not required		1.5...15 kHz, 1...10 V 15...150 kHz, 10 V 50/60 Hz, 100 V	1.5...15 kHz, 1...10 V 15...150 kHz, 10 V 50/60 Hz, 100 V	FS	15 Hz...150 kHz, 10 V 50 Hz, 300 Ω, 230 V	A 0.5%

9000 EMC specifications - immunity:

	Essential operation (functional safety)	Continuous unmonitored operation	Continuous monitored operation	Non-continuous operation
ESD IEC 61000-4-2	A	B	B	C
EM IEC 61000-4-3	A	A	A	B
Burst IEC61000-4-4	A	B	B	B
Surge IEC 61000-4-5	A	B	B	C
Conducted RF IEC 61000-4-6	A	A	A	C
Voltage interrupts IEC 61000-4-11	A	B	C	C

Note For type testing, it is highly recommended that performance criteria A be chosen for all phenomena and all tests. However, performance criteria B and/or C may be accepted provided that both the specification and the test report highlight such deviation(s) for the relevant combination(s) of function and test.

Specified function	Normal test level	Increased test level
Normal function	Normal specification (performance criteria A; B; C)	May fail
Safety function	Performance criteria - A, or - B + observed deviation + recovery time to be documented in the data sheet, or - C + observed behaviour documented in the data sheet	Performance criteria FS (i.e. no effect outside the specification, or defined state)

A: During testing, normal performance within the specification limits.

B: During testing, temporary degradation, or loss of function or performance which is self recovering.

C: During testing, temporary degradation, or loss of function or performance which requires operator intervention or system reset occurs.

9000 EMC specifications - emission:

Class B equipment		Standard CISPR 22	
Disturbance	Test method	Frequency range	Limits
Radiated	Quasi-peak	30 to 230 MHz	30 dB ($\mu\text{V}/\text{m}$)
		230 to 1000 MHz	37 dB ($\mu\text{V}/\text{m}$)
Conducted	Quasi-peak	0.15...0.50 MHz	40 to 30 dB (μA)
	Average		30 to 20 dB (μA)
	Quasi-peak	0.50 to 30 MHz	30 dB (μA)
	Average		20 dB (μA)