

High-Precision Torque Sensor

rotating, contactless

MODEL 8661



Highlights

- Measurement ranges of 0 ... 0.02 N·m to 0 ... 1000 N·m
- Very low linearity error $\leq \pm 0.05$ % F.S.
- Output signal 0 ... ± 10 V
- Refresh rate 2000 measurements/s

Options

- Speed and angle measurement up to 2000 increments
- Dual range in different graduations
- Shaft end with keyway
- USB port including software

Applications

- Research & development
- Machinery and plant engineering
- Electric motor test
- Suitable for use in all types of test bench



With mounting block



With mounting block and couplings

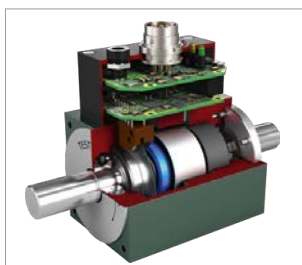

In the cross-section



With couplings

Product description

The non-contact torque sensor type 8661 works according to the strain gage principle. Thanks to the inductive and optical transmission of the signals, the sensor is maintenance-free, the signals are digitized directly on the shaft and made available by the evaluation electronics as a voltage signal or via USB. Thanks to the high-quality bearing, depending on the measuring range, up to 25,000 rpm is possible. The bidirectional voltage output from -10 V ... +10 V allows the direction of rotation to be identified very easily.

To record the speed and angle of rotation, the sensor can optionally be equipped with different number of increments, up to 2000. This speed / angle signal is available as a TTL output signal.

The free DigiVision Light software is available in connection with USB, alternatively drivers for LabVIEW and DASyLab are ready for download.

Connection cables in various lengths, metal bellows couplings and mounting blocks are available for integration in customer-specific systems.

Technical Data

| 8661 | - | 4020 | 4050 | 4100 | 4200 | 4500 | 5001 | 5002 | 5005 | 5010 | 5020 | |
|--|---------------------------------------|--|-----------|----------|-------------|--|------------|--------|--------|---------|---------|--|
| Measuring range calibrated in N·m from 0 ... | | ±0.02 N·m | ±0.05 N·m | ±0.1 N·m | ±0.2 N·m | ±0.5 N·m | ±1 N·m | ±2 N·m | ±5 N·m | ±10 N·m | ±20 N·m | |
| Accuracy | | | | | | | | | | | | |
| Relative non-linearity | | 0.1 % F.S. | | | 0.05 % F.S. | | | | | | | |
| Relative non-linearity dual range sensor | | - | | | | | 0.1 % F.S. | | | | | |
| Relative hysteresis | | < 0.1 % F.S. / dual range sensor < 0.2 % F.S. | | | | | | | | | | |
| Tolerance of sensitivity | | ±0.1 % F.S. / dual range sensor ±0.2 % F.S. | | | | | | | | | | |
| Electrical values | | | | | | | | | | | | |
| Rated supply voltage range | | 10 ... 30 V DC (or 5 V via USB) | | | | | | | | | | |
| DC power consumption | | approx. 2 W | | | | | | | | | | |
| Output voltage at ± rated torque | | ±10 V | | | | | | | | | | |
| Output resistance | | 1 kΩ | | | | | | | | | | |
| Insulation resistance | | > 5 MΩ | | | | | | | | | | |
| Refresh rate | | 2000/sec. | | | | | | | | | | |
| Ripple | | < 50 mV _{ss} | | | | | | | | | | |
| Control signal | | 10.00 V DC | | | | | | | | | | |
| Resolution | | 16 bit ± 0.38 mV | | | | | | | | | | |
| Environmental conditions | | | | | | | | | | | | |
| Range of operating and nominal temperature | | 0 °C ... +60 °C | | | | | | | | | | |
| Sensitivity of temperature effects | | on the zero point 0.015 % F.S./K / 2. measuring range dual range sensor 0.03 % F.S./K on the sensitivity 0.010 % F.S./K / 2. measuring range dual range sensor 0.02 % F.S./K | | | | | | | | | | |
| Mechanical values | | | | | | | | | | | | |
| Dynamic overload safe | | recommended 70 % of nominal torque | | | | | | | | | | |
| Max. operation torque | | 200 % of nominal torque / dual range sensor 150 % | | | | | | | | | | |
| Breakaway torque | | 300 % of nominal torque | | | | | | | | | | |
| Alternating load | | 70 % of nominal torque | | | | | | | | | | |
| Maximum limit axial load | [N] | 50 | | | | | 200 | | | | | |
| Maximum limit radial load | [N] | 3 | | | 4 | 7 | 13 | 15 | 30 | 60 | | |
| Spring constant | [N·m/rad] | 10 | 20 | 50 | 100 | | 180 | 800 | 1700 | 3000 | | |
| Mass moment of inertia measuring side | [10 ⁻⁶ kg·m ²] | 0.048 | | | 0.05 | 0.06 | 0.062 | 0.077 | 2.2 | 2.35 | 2.6 | |
| Mass moment of inertia drive side | [10 ⁻⁶ kg·m ²] | 2.2 | | | | | | | 14.3 | | 14.6 | |
| Max. rotary speed | [min ⁻¹] | 25000 | | | | | 15000 | | | | | |
| Other | | | | | | | | | | | | |
| Material | | Housing: made of anodized aluminium; Shaft: high-strength aluminium 3.1354; shaft ends stainless steel 1.4542 | | | | Housing: made of anodized aluminium Shaft: stainless steel 1.4542 | | | | | | |
| Protection class | | acc. EN 60529, IP40 | | | | | | | | | | |
| Weight | [g] | 300 | | | | | 900 | | | | | |
| Installation | | | | | | | | | | | | |
| Installation instructions | | Do not exceed the permitted axial and radial forces during fitting and operation. Please refer to our operating instructions for detailed information www.burster.com . Suitable couplings should be used to avoid strain resulting from parallel or angular offset between the shafts. | | | | | | | | | | |

Technical Data

| 8661 | - | 5025 | 5050 | 5100 | 5200 | 5300 | 5400 | 5500 | 5800 | 6001 | |
|--|---------------------------------------|---|---------|----------|----------|-----------|----------|----------|----------|-----------|--|
| Measuring range calibrated in N·m from 0 ... | | ±25 N·m | ±50 N·m | ±100 N·m | ±200 N·m | ±300 N·m | ±400 N·m | ±500 N·m | ±800 N·m | ±1000 N·m | |
| Accuracy | | | | | | | | | | | |
| Relative non-linearity | | 0.05 % F.S. | | | | | | | | | |
| Relative non-linearity dual range sensor | | 0.1 % F.S. | | | | | | | | | |
| Relative hysteresis | | < 0.1 % F.S. / dual range sensor < 0.2 % F.S. | | | | | | | | | |
| Tolerance of sensitivity | | ±0.1 % F.S. / dual range sensor ±0.2 % F.S. | | | | | | | | | |
| Electrical values | | | | | | | | | | | |
| Rated supply voltage range | | 10 ... 30 V DC (or 5 V via USB) | | | | | | | | | |
| DC power consumption | | approx. 2 W | | | | | | | | | |
| Output voltage at ± rated torque | | ±10 V | | | | | | | | | |
| Output resistance | | 1 kΩ | | | | | | | | | |
| Insulation resistance | | > 5 MΩ | | | | | | | | | |
| Refresh rate | | 2000/sec. | | | | | | | | | |
| Ripple | | < 50 mV _{ss} | | | | | | | | | |
| Control signal | | 10.00 V DC | | | | 5.00 V DC | | | | | |
| Resolution | | 16 bit ± 0.38 mV | | | | | | | | | |
| Environmental conditions | | | | | | | | | | | |
| Range of operating and nominal temperature | | 0 °C ... +60 °C | | | | | | | | | |
| Sensitivity of temperature effects | | on the zero point 0.015 % F.S./K / 2. measuring range dual range sensor 0.03 % F.S./K on the sensitivity 0.010 % F.S./K / 2. measuring range dual range sensor 0.02 % F.S./K | | | | | | | | | |
| Mechanical values | | | | | | | | | | | |
| Dynamic overload safe | | recommended 70 % of nominal torque | | | | | | | | | |
| Max. operation torque | | 200 % of nominal torque / dual range sensor 150 % | | | | | | | | | |
| Breakaway torque | | 300 % of nominal torque | | | | | | | | | |
| Alternating load | | 70 % of nominal torque | | | | | | | | | |
| Maximum limit axial load | [N] | 300 | | | | 500 | | | | | |
| Maximum limit radial load | [N] | 125 | 215 | | 250 | | | 500 | | | |
| Spring constant | [N·m/rad] | 14000 | 25000 | 40000 | 150000 | | | 220000 | | | |
| Mass moment of inertia measuring side | [10 ⁻⁶ kg·m ²] | 33.3 | 33.7 | 35.0 | 600 | | | | | | |
| Mass moment of inertia drive side | [10 ⁻⁶ kg·m ²] | 85.7 | 85.9 | 85.5 | 1200 | | | | | | |
| Max. rotary speed | [min ⁻¹] | 15000 | | | | 7000 | | | | | |
| Other | | | | | | | | | | | |
| Material | | Housing: made of anodized aluminium; Shaft: stainless steel 1.4542 | | | | | | | | | |
| Protection class | | acc. EN 60529, IP40 | | | | | | | | | |
| Weight | [g] | 1500 | | | | 6000 | | | | | |
| Installation | | | | | | | | | | | |
| Installation instructions | | Do not exceed the permitted axial and radial forces during fitting and operation. Please refer to our operating instructions for detailed information www.burster.com . Suitable couplings should be used to avoid strain resulting from parallel or angular offset between the shafts. | | | | | | | | | |

Dimensional drawing

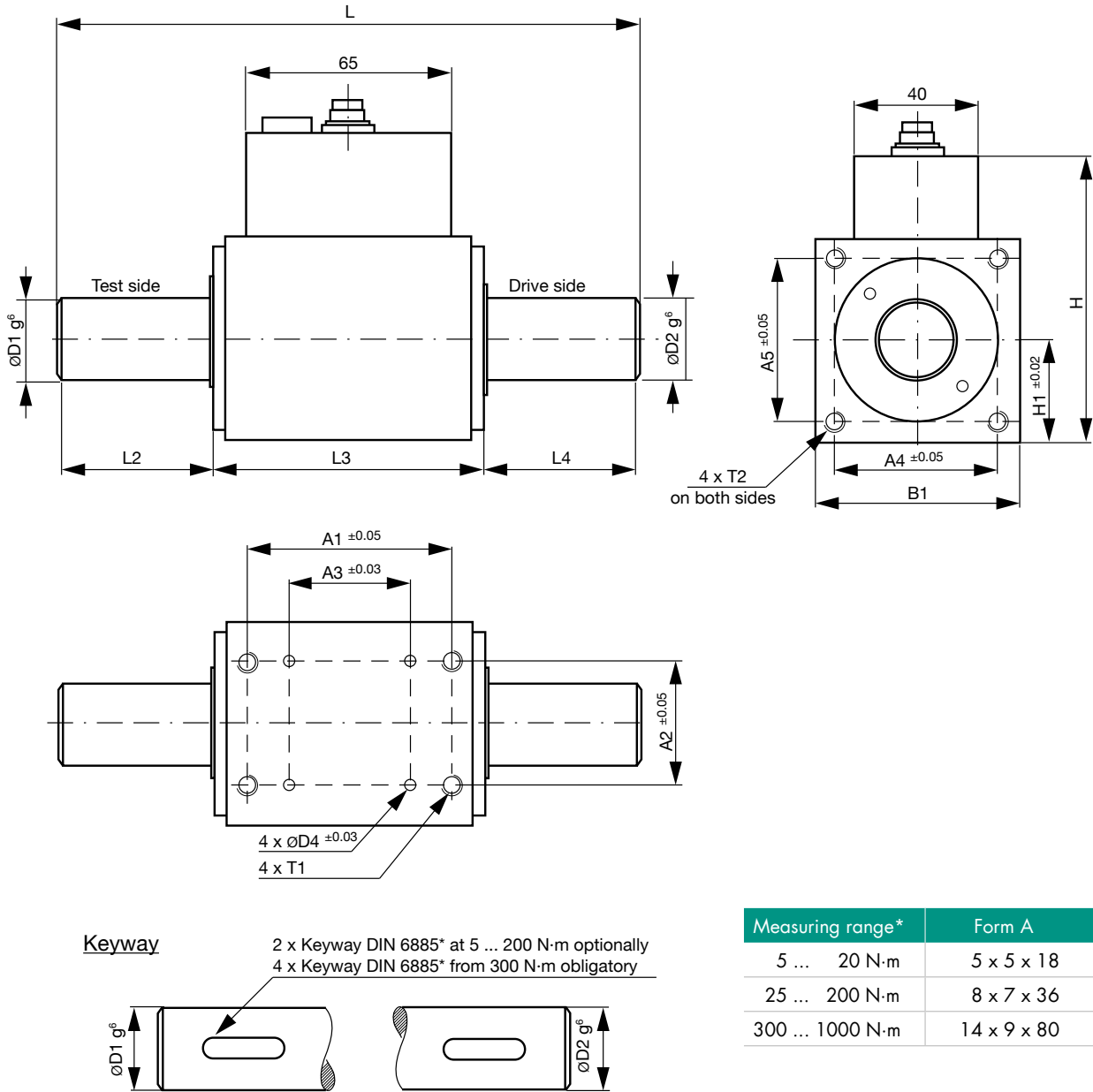

| Measuring range* | Form A |
|------------------|-------------|
| 5 ... 20 N·m | 5 x 5 x 18 |
| 25 ... 200 N·m | 8 x 7 x 36 |
| 300 ... 1000 N·m | 14 x 9 x 80 |

For detailed dimensions you can find sensor CAD data on our website www.burster.com.
 All dimensions without tolerance specifications comply with ISO 2768-fH.

| 8661 | - | 4020 | 4050 | 4100 | 4200 | 4500 | 5001 | 5002 | 5005 | 5010 | 5020 |
|----------------------------|------|--------------|--------------|-------------|-------------|-------------|-----------|-----------|-----------|------------|------------|
| Measuring range from 0 ... | | ±0.02 N·m | ±0.05 N·m | ±0.1 N·m | ±0.2 N·m | ±0.5 N·m | ±1 N·m | ±2 N·m | ±5 N·m | ±10 N·m | ±20 N·m |
| Geometry | | | | | | | | | | | |
| A1 | [mm] | | | | 45 | | | | | | 57 |
| A2 | [mm] | | | | 31 | | | | | | 44 |
| A3 | [mm] | | | | 30 | | | | | | 41 |
| A4 | [mm] | | | | 26 | | | | | | 45.3 |
| A5 | [mm] | | | | 24 | | | | | | 45.3 |
| B1 | [mm] | | | | 40 | | | | | | 55 |
| D1 | [mm] | | | | 5g6 | | | 6g6 | | | 15g6 |
| D2 | [mm] | | | | 8g6 | | | | | | 15g6 |
| D4 Ø / deep | [mm] | | | | | | | Ø 3.1 / 5 | | | |
| H | [mm] | | | | 60 | | | | | | 85 |
| H1 | [mm] | | | | 15 | | | | | | 27.5 |
| L | [mm] | | | | 87 | | | 94 | | | 143 |
| L2 | [mm] | | | | 10 | | | 14 | | | 30 |
| L3 | [mm] | | | | 66 | | | | | | 83 |
| L4 | [mm] | | | | 11 | | | 14 | | | 30 |
| T1 / deep | [mm] | | | | M4 / 8 | | | | | | M5 / 9 |
| T2 / deep | [mm] | | | | M3 / 5.5 | | | | | | M4 / 6 |

| 8661 | - | 5025 | 5050 | 5100 | 5200 | 5300 | 5400 | 5500 | 5800 | 6001 |
|----------------------------|------|------------|------------|-------------|-------------|-------------|-------------|-------------|-------------|--------------|
| Measuring range from 0 ... | | ±25 N·m | ±50 N·m | ±100 N·m | ±200 N·m | ±300 N·m | ±400 N·m | ±500 N·m | ±800 N·m | ±1000 N·m |
| Geometry | | | | | | | | | | |
| A1 | [mm] | | | 57 | | | | | 50 | |
| A2 | [mm] | | | 44 | | | | | 90 | |
| A3 | [mm] | | | 41 | | | | | 30 | |
| A4 | [mm] | | | 54.4 | | | | | 88.4 | |
| A5 | [mm] | | | 54.4 | | | | | 88.4 | |
| B1 | [mm] | | | 64 | | | | | 107 | |
| D1 | [mm] | | | 26g6 | | | | | 45g6 | |
| D2 | [mm] | | | 26g6 | | | | | 45g6 | |
| D4 Ø / deep | [mm] | | | Ø 3.1 / 5 | | | | | Ø 4.1 / 10 | |
| H | [mm] | | | 94 | | | | | 137 | |
| H1 | [mm] | | | 32 | | | | | 53.5 | |
| L | [mm] | | | 168 | | | | | 285 | |
| L2 | [mm] | | | 45 | | | | | 95 | |
| L3 | [mm] | | | 78 | | | | | 95 | |
| L4 | [mm] | | | 45 | | | | | 95 | |
| T1 / deep | [mm] | | | M5 / 8 | | | | | M8 / 20 | |
| T2 / deep | [mm] | | | M4 / 6 | | | | | M6 / 10 | |

All dimensions without tolerance specifications comply with ISO 2768-fH.



Electrical values

12-pin connector or USB (Option, USB connection cable included)

| Wiring Code depends on the options selected | | |
|---|---|-----------------------------------|
| Pin | Assignment | Cable colour (99540-000F-052XXXX) |
| A | NC | |
| B | Angular exit B | violet |
| C | Moment output + | yellow |
| D | Moment output - | green |
| E | Supply - | blue |
| F | Supply + | red |
| G | Angular exit A | pink |
| H | NC | |
| J | Ground angle output, measuring range switchover | black |
| K | Control signal | White |
| L | Measuring range switchover | brown |
| M | NC | |

Accessories

Mounting block Model 8661-Z00X



If the sensor needs to be replaced, the locating pin speeds up replacement, avoiding the need for laborious realignment. This can be useful especially when the sensor is only used occasionally in the load path. The mounting block has a central hole and special design allowing a range of options for reliable cable attachment. Two clips ensure the sensor is fixed securely. For further information please see accessories data sheet 8661-Z00X

Metal bellow couplings Model 8695



For optimum compensation of misalignment we recommend torsionally free metal bellow couplings. They are characterized by their excellent torsional stiffness during torque load and their low restoring forces. The couplings are optionally with keyways available. For further information please see accessories data sheet 8695.

Options

USB interface



This sensor version has a USB connection instead of the ± 10 V output. The sensor is powered via USB, no further connections required.

In addition to torque, the speed or rotation angle measured values are optionally available. The calculated mechanical performance in is also displayed in DigiVision.

Free drivers are available for integration into LabVIEW and DASyLab, also a DLL for integration into your own programs.



Messtechnik Schaffhausen GmbH

Mühlenstrasse 4, CH-8260 Stein am Rhein, Telefon +41 52-672 50 00, Telefax +41 52-672 50 01, www.mts.ch, e-mail: info@mts.ch

Messen Prüfen Automatisieren www.mts.ch

Dual range

The sensor with two measuring ranges corresponds to its dimensions of the standard version, but has two separately calibrated measuring ranges. The measuring ranges are switched within <50 ms, even during measurement operation, by applying the operating voltage to pin L or via USB.

Torque sensor with integrated rotational speed / angular displacement measurement

8661 torque sensors are optionally available with integrated rotational speed and angular displacement measurement. Two pulse channels with TTL level – channel A and channel B – are always available. For clockwise rotation (looking at the test side), channel A leads channel B with a phase shift of 90°. Only one pulse channel is needed for speed measurement.

For angular displacement measurement (or direction detection), both channels need to be evaluated. To achieve the maximum angular resolution, four-edge decoding must be used to read both the rising and falling edges. For instance an angular resolution of up to 0.045° can then be achieved with an encoder disk having 2000 increments.

Maximum speed:

| | | |
|-------------------|------------------|---------------------------|
| Encoder disk with | 2000 increments: | ≤ 3000 min ⁻¹ |
| Encoder disk with | 1024 increments: | ≤ 6000 min ⁻¹ |
| Encoder disk with | 400 increments: | ≤ 15000 min ⁻¹ |
| Encoder disk with | 240 increments: | ≤ 25000 min ⁻¹ |

| Increments | from 0 ... 0,02 N·m to 0 ... 2 N·m | from 0 ... 5 N·m to 0 ... 200 N·m | from 0 ... 300 N·m to 0 ... 1000 N·m |
|------------|---------------------------------------|--------------------------------------|---|
| 2000 | - | yes | - |
| 1024 | yes | yes | yes |
| 400 | yes | yes | - |
| 240 | yes | - | - |

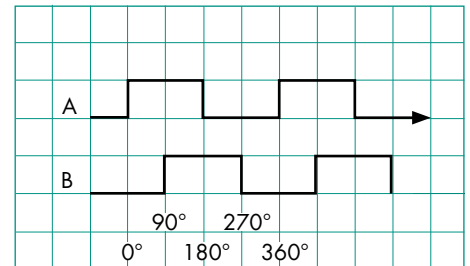

The measuring accuracy of the rotational speed and angular displacement measurement is directly related to the speed and the encoder disk used. With the USB option, another influencing factor is the setting of the averaging, which should be adapted to the speed range used.

DigiVision configuration and analysis software

Features

- Tare function
- Configuration options for averaging and filters; value stored in sensor
- Intuitive user interface
- Automatic sensor identification
- Sensor calibration data readout

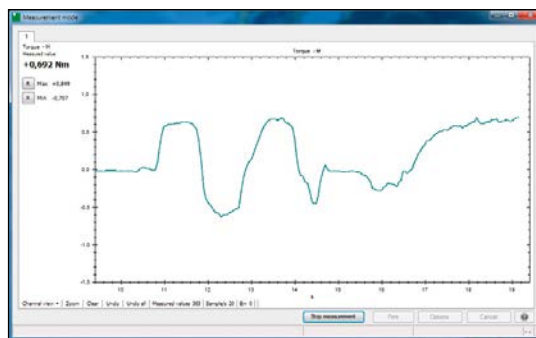

| DigiVision Light PC software | |
|-------------------------------------|--|
| freely available on our website | DigiVision configuration and analysis software max. 200 measured value/s for one sensor |
| DigiVision Standard PC software | |
| Model 8661-P100 | DigiVision configuration and analysis software up to 16 channels, no limit to the refresh rate |
| PC-Software DigiVision Professional | |
| Model 8661-P200 | DigiVision configuration and analysis software with additional configurable maths channel; up to 32 channels |

- Numerical & graphical display and measurement of the physical torque value
- Practical start and stop trigger functions
- 4 limits can be configured for each measurement channel
- MIN/MAX value acquisition
- Automatic scaling
- Measurement reports can be saved as Excel or PDF file
- Archive viewer for displaying sets of curves
- X Multichannel measurements, even with different sensors (e.g. 9206, 8631, 8625) available with standard version

Accessories

| Order code | |
|--------------------|--|
| 9940 | Mating connection 12 pin |
| 9900-V539 | Mating connection 90°-angle |
| 99540-000F-0520030 | Connecting cable, length 3 m, other end free |
| 99539-000F-0520030 | Connecting cable, length 3 m, plug with 90°-angle, other end free |
| 99209-540G-0160030 | Connecting cable for model 7281 and model 9311, length 3 m, with external supply |
| 99163-540A-0520030 | Connecting cable, length 3 m, 8661 to DIGIFORCE® 9307 combined channel D (option channel) |
| 99209-215A-0090004 | Adapter cable to DIGIFORCE® 9307 standard channel A/B and C (usable only in connection with type 99163-540A-052xxxx) |
| 8661-Z010 | USB cable connector type A, type BMini, length 2 m, black (included with USB option) |
| 8661-P100 | DigiVision Standard configuration and analysis software; up to 16 channels |
| 8661-P200 | DigiVision Professional with additional configurable maths channel; up to 32 channels |
| 8600-Z00X | Mounting block, see accessories data sheet 8661-Z00X |
| 8600-Z010 | Power pack for external supply |

Calibration

| Manufacturer Calibration Certificate (WKS) | |
|---|--|
| | Special calibration for clockwise or/and counter clockwise direction torque, in 20 % steps of range up and down. |
| Calibration Certificate with accreditation symbol | |
| | Calibration certificate with accreditation symbol per DIN 51309, clockwise or/and anticlockwise torque, with eight steps spaced across the measurement range, increasing and decreasing. |

