

2-WIRE HART® TRANSMITTER



- RTD, TC, Ohm, or mV input
- Extremely high measurement accuracy
- HART® communication
- Can be installed in Ex zone 0
- 1- or 2-channel version



Application:

- Linearised temperature measurement with Pt100...Pt1000, Ni100...Ni1000, or TC sensor.
- Difference or average temperature measurement of 2 resistance or TC sensors.
- Conversion of linear resistance variation to a standard analogue current signal, for instance from valves or Ohmic level sensors.
- Amplification of a bipolar mV signal to a standard 4...20 mA current signal.
- Connection of up to 15 channels to a digital 2-wire signal with HART® communication.

Technical characteristics:

- Within a few seconds the user can program PR6335D to measure temperatures within all ranges defined by the norms.
- The RTD and resistance inputs have cable compensation for 2-, 3- and 4-wire connection.
- The 6335D has been designed according to strict safety requirements and is thus suitable for application in SIL 2 installations.
- Continuous check of vital stored data for safety reasons.
- Sensor error detection according to the guidelines in NAMUR NE 89.

Mounting / installation:

- Mounted vertically or horizontally on a DIN rail. As the modules can be mounted without any distance between neighbouring units, up to 84 channels can be mounted per metre.
- **NB:** As Ex barrier we recommend 5106B.

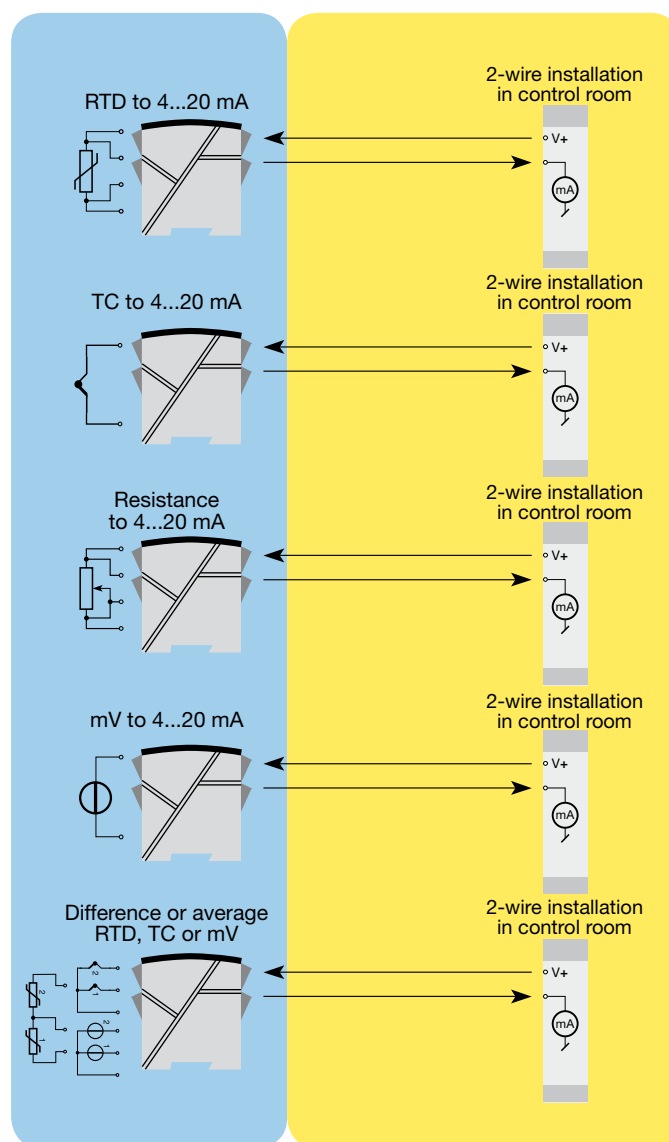

Messtechnik Schaffhausen GmbH
 Mühlenstrasse 4, CH-8260 Stein am Rhein
 Telefon +41 52-672 50 00
 Telefax +41 52-672 50 01
 www.mts.ch, e-mail: info@mts.ch

Order: 6335D

Type	Galvanic isolation	Channels
6335D	1500 VAC : 2	Single : A Double : B

***NB!** Please remember to order CJC connectors type 5910Ex (channel 1) and 5913Ex (channel 2) for TC inputs with an internal CJC.

Connections:

All connection options are shown in the user manual.

Inputs:

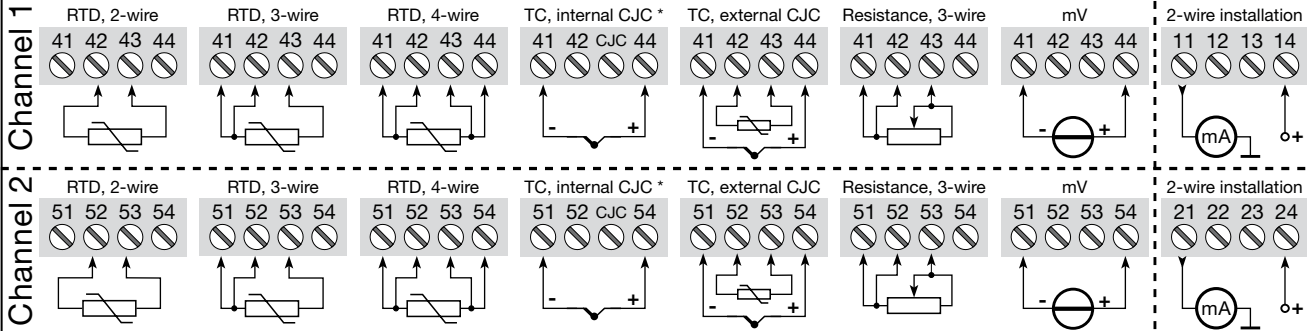

Outputs:

Electrical specifications:

Specifications range:

-40°C to +60°C

Common specifications:

Supply voltage..... 8.0...30 VDC
 Voltage drop 8.0 VDC
 Isolation voltage, test / operation..... 1.5 kVAC / 50 VAC
 Isolation voltage, ch. 1 / ch. 2 1500 VAC
 Communications interface Loop Link & HART®
 Signal / noise ratio..... Min. 60 dB
 Response time (programmable) 1...60 s
 Signal dynamics, input 22 bit
 Signal dynamics, output..... 16 bit
 Calibration temperature..... 20...28°C
 Accuracy, the greater of general and basic values:

TC input:

Type	Min. temperature	Max. temperature	Min. span	Standard
B	+400°C	+1820°C	100°C	IEC584
E	-100°C	+1000°C	50°C	IEC584
J	-100°C	+1200°C	50°C	IEC584
K	-180°C	+1372°C	50°C	IEC584
L	-100°C	+900°C	50°C	DIN 43710
N	-180°C	+1300°C	50°C	IEC584
R	-50°C	+1760°C	100°C	IEC584
S	-50°C	+1760°C	100°C	IEC584
T	-200°C	+400°C	50°C	IEC584
U	-200°C	+600°C	50°C	DIN 43710
W3	0°C	+2300°C	100°C	ASTM E988-90
W5	0°C	+2300°C	100°C	ASTM E988-90

General values		
Input type	Absolute accuracy	Temperature coefficient
All	≤ ±0.05% of span	≤ ±0.005% of span / °C

Basic values		
Input type	Basic accuracy	Temperature coefficient
Pt100 and Pt1000	≤ ±0.1°C	≤ ±0.005°C/°C
Ni100	≤ ±0.2°C	≤ ±0.005°C/°C
Lin. R	≤ ±0.1 Ω	≤ ±5 mΩ / °C
Volt	≤ ±10 μV	≤ ±0.5 μV / °C
TC type: E, J, K, L, N, T, U	≤ ±0.5°C	≤ ±0.025°C / °C
TC type: B, R, S, W3, W5	≤ ±1°C	≤ ±0.1°C / °C

EMC immunity influence < ±0.1% of span
 Extended EMC immunity:
 NAMUR NE 21, A criterion, burst < ±1% of span
 Humidity < 95% RH (non-cond.)
 Dimensions (H x W x D)..... 109 x 23.5 x 104 mm
 Protection degree IP20
 Weight (1 / 2 channels)..... 145 / 185 g

Electrical specifications, input:

Max. offset..... 50% of selec. max. value

RTD and linear resistance input:

RTD type	Min. value	Max. value	Min. span	Standard
Pt100	-200°C	+850°C	10°C	IEC 60751
Ni100	-60°C	+250°C	10°C	DIN 43760
Lin. R	0 Ω	7000 Ω	25 Ω	----

Cable resistance per wire (max.) 5 Ω

Sensor current..... Nom. 0.2 mA

Cold junction compensation < ±1.0°C

Voltage input:

Measurement range -800...+800 mV
 Min. span..... 2.5 mV
 Input resistance 10 MΩ

Current output:

Signal range 4...20 mA
 Min. signal range 16 mA
 Updating time..... 440 ms
 Load resistance ≤ (V_{supply} - 8) / 0.023 [Ω]

Sensor error detection:

Programmable..... 3.5...23 mA

Ex / I.S. approvals:

ATEX KEMA 09ATEX0148..... II 1 G Ex ia IIC
 Applicable in zone 0, 1 or 2
 ATEX Installation Drawing No. 6335QA01
 IECEx KEM 10.0084 Ex ia IIC T5 Ga
 IECEx Installation Drawing No. ... 6335QI01
 FM, applicable in IS, Cl. I, Div. 1, Gr. A, B, C, D
 IS, Cl. I, Zone 0, AEx ia IIC
 FM Installation Drawing No. 6335QF01
 CSA, applicable in IS, Cl. I, Div. 1, Gr. A, B, C, D
 Ex ia IIC
 IS, Cl. I, Zone 0, AEx ia IIC
 CSA Installation Drawing No. 6335QC02

GOST R approval:

VNIIFTRI, Cert. no. www.preelectronics.com

Observed authority requirements: Standard:

EMC 2004/108/EC EN 61326-1
 ATEX 94/9/EC EN 60079-0, -11, -26
 IECEx IEC 60079-0, -11, -26
 FM 3600, 3610, 3611
 CSA, CAN / CSA C22.2 No. 157,
 E60079-11, UL 913

Of span = Of the presently selected range