

2-WIRE TRANSMITTER WITH HART® PROTOCOL



- RTD, TC, Ohm, or mV input
- Extremely high measurement accuracy
- HART® communication
- Galvanic isolation
- For DIN form B sensor head mounting



Application:

- Linearised temperature measurement with Pt100...Pt1000, Ni100...Ni1000, or TC sensor.
- Difference or average temperature measurement of 2 resistance or TC sensors.
- Conversion of linear resistance variation to a standard analogue current signal, for instance from valves or Ohmic level sensors.
- Amplification of a bipolar mV signal to a standard 4...20 mA current signal.
- Connection of up to 15 transmitters to a digital 2-wire signal with HART® communication.

Technical characteristics:

- Within a few seconds the user can program PR5335D to measure temperatures within all ranges defined by the norms.
- The RTD and resistance inputs have cable compensation for 2-, 3- and 4-wire connection.
- The 5335D has been designed according to strict safety requirements and is thus suitable for application in SIL 2 installations.
- Continuous check of vital stored data for safety reasons.
- Sensor error detection according to the guidelines in NAMUR NE 89.

Mounting / installation:

- For DIN form B sensor head mounting.
- **NB:** As Ex barrier we recommend 5106B.

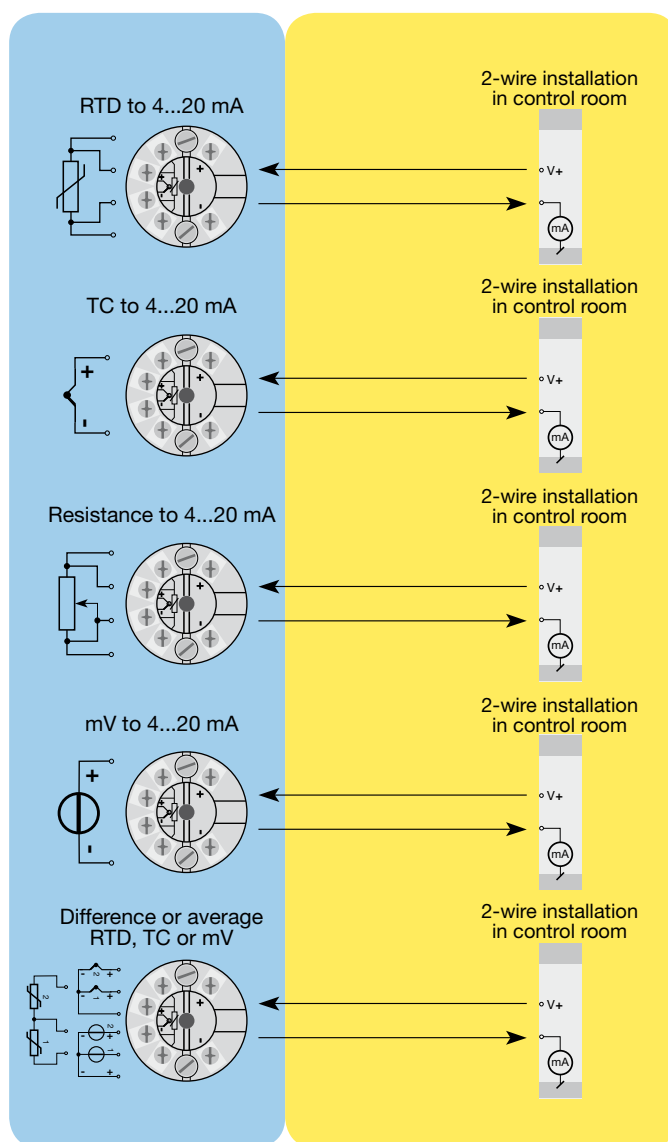

Order: 5335D

Type
5335D

Connections:

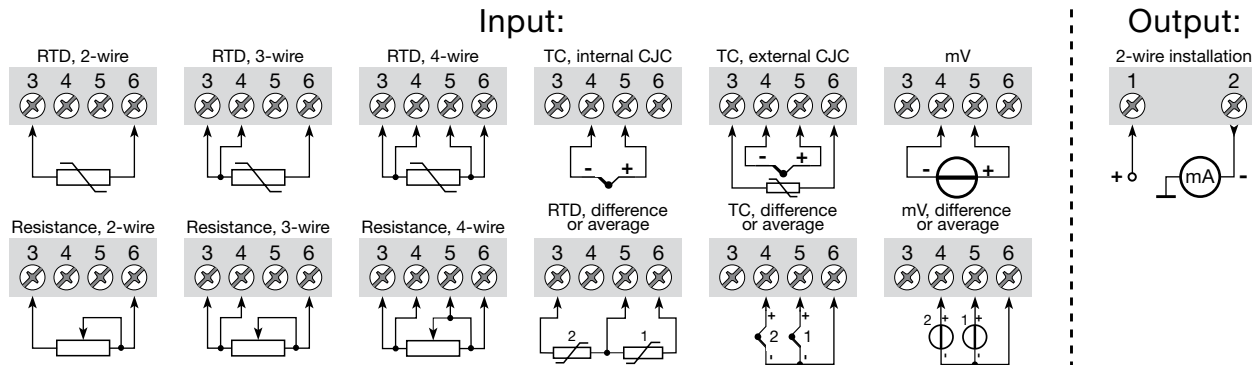

Electrical specifications:

Specifications range:

-40°C to +85°C

Common specifications:

Supply voltage..... 8.0...30 VDC
 Voltage drop 8.0 VDC
 Isolation voltage, test / operation..... 1.5 kVAC / 50 VAC
 Communications interface Loop Link & HART®
 Signal / noise ratio..... Min. 60 dB
 Signal dynamics, input 22 bit
 Signal dynamics, output..... 16 bit
 Calibration temperature..... 20...28°C
 Accuracy, the greater of general and basic values:

General values		
Input type	Absolute accuracy	Temperature coefficient
All	≤ ±0.05% of span	≤ ±0.005% of span / °C

Basic values		
Input type	Basic accuracy	Temperature coefficient
Pt100 and Pt1000	≤ ±0.1°C	≤ ±0.005°C/°C
Ni100	≤ ±0.2°C	≤ ±0.005°C/°C
Lin. R	≤ ±0.1 Ω	≤ ±5 mΩ / °C
Volt	≤ ±10 μV	≤ ±0.5 μV / °C
TC type: E, J, K, L, N, T, U	≤ ±0.5°C	≤ ±0.025°C / °C
TC type: B, R, S, W3, W5	≤ ±1°C	≤ ±0.1°C / °C

EMC immunity influence	< ±0.1% of span
Extended EMC immunity: NAMUR NE 21, A criterion, burst	< ±1% of span

Vibration IEC 60068-2-6 Test FC
 Lloyd's specification no. 1 4 g / 2...100 Hz
 Humidity < 95% RH (non-cond.)
 Dimensions..... Ø 44 x 20.2 mm
 Protection degree (encl. / terminals)... IP68 / IP00

Electrical specifications, input:

Max. offset..... 50% of select. max. value

RTD and linear resistance input:

RTD type	Min. value	Max. value	Min. span	Standard
Pt100	-200°C	+850°C	10°C	IEC 60751
Ni100	-60°C	+250°C	10°C	DIN 43760
Lin. R	0 Ω	7000 Ω	10 Ω	-----

Cable resistance per wire (max.) 5 Ω

Sensor current..... Nom. 0.2 mA

Voltage input:

Measurement range -800...+800 mV
 Min. span..... 2.5 mV
 Input resistance 10 MΩ

TC input:

Type	Min. temperature	Max. temperature	Min. span	Standard
B	+400°C	+1820°C	100°C	IEC584
E	-100°C	+1000°C	50°C	IEC584
J	-100°C	+1200°C	50°C	IEC584
K	-180°C	+1372°C	50°C	IEC584
L	-100°C	+900°C	50°C	DIN 43710
N	-180°C	+1300°C	50°C	IEC584
R	-50°C	+1760°C	100°C	IEC584
S	-50°C	+1760°C	100°C	IEC584
T	-200°C	+400°C	50°C	IEC584
U	-200°C	+600°C	50°C	DIN 43710
W3	0°C	+2300°C	100°C	ASTM E988-90
W5	0°C	+2300°C	100°C	ASTM E988-90

Cold junction compensation ≤ ±1.0°C

Current output:

Signal range 4...20 mA
 Min. signal range 16 mA
 Updating time..... 440 ms
 Load resistance ≤ (V_{supply} - 8) / 0.023 [Ω]

Sensor error detection:

Programmable..... 3.5...23 mA

Ex / I.S. approvals:

IECEX certificate..... KEM 10.0083
 ATEX certificate KEMA 03ATEX1537
 FM certificate..... 2D5A7.AX
 CSA certificate..... 1125003
 INMETRO certificate..... 09/UL-BRCO-0002

Marine approval:

Det Norske Veritas, Ships & Offshore. Stand. f. Certific. No. 2.4

GOST R approval:

VNIIM & VNIIFTRI, Cert. no. www.preelectronics.com

Observed authority requirements: Standard:

EMC 2004/108/EC EN 61326-1
 ATEX 94/9/EC..... EN 60079-0, -11, -26
 EN 61241-0, -11
 IEC 60079-0, -11, 26,
 IEC 61241-11
 FM 3600, 3611, 3610
 CSA, CAN / CSA C22.2 No. 157,
 E60079-11, UL 913
 INMETRO IEC 60079-0, -11

Of span = Of the presently selected range