

# PROGRAMMABLE f/I - f/f CONVERTER



- Pulse conditioning
- Frequency generator
- Concurrent f/I and f/f function
- Analogue current and voltage output
- PNP / NPN output, optional relays
- Programmable by PC and Loop Link



Supply voltage:	24 VDC
<b>INPUT RANGE:</b>	
Frequency:	0...20000 Hz
Sensor types:	NAMUR, tacho, NPN, PNP, TTL, SO
<b>OUTPUT RANGE:</b>	
Current and voltage output:	0...20 mA / 0...10 V
Relay outputs:	0...20 Hz
NPN and PNP output as f/f:	0...1000 Hz
NPN and PNP output as generator:	0...20000 Hz

#### In general:

By way of a standard PC and the Loop Link programming kit, the PRecon 5225 f/I - f/f Converter is configured acc. to the requested function.

Alternatively, the 5225 may be delivered fully-configured acc. to your specifications, see the Options Index on the next page.

Typical pulse sources are flow meters, tacho generators, mechanical switches, or inductive proximity sensors.

#### Applications:

**The f/I function** performs frequency to current and voltage conversion.

The output can be programmed to show period meaning that the input frequency can be converted to a linear time signal.

The digital outputs are used as e.g. a frequency watch for speed control or as a window comparator having one status between 2 limits and the opposite status outside these limits.

**The f/f function** can be used for pulse division or multiplication and as a buffer collecting fast pulse trains. The input pulses are calculated, counted in a buffer, and sent to the output as a pulse train with the programmed pulse width.

**The concurrent f/I and f/f functions** enable a scaled digital output signal in conjunction with the analogue output.

**The frequency generator function** is used as e.g. a time base or clock generator.

#### Technical characteristics:

##### Input:

Programmable input for standard pulse generator connection. Normally, the auxiliary supply and trigger level follow the sensor type, but these can be programmed acc. to other values. At contact input, the 50 Hz filter should be applied. The PRecon 5225 is protected against polarity reversal on input and supply.

##### Analogue output:

The analogue current and voltage output can be scaled acc. to your choice in relation to the digital input. Max. zero offset is 50% of selected measurement range. Programmable response time. Short-circuit-protected output. When both current and voltage signals are used simultaneously, the mA loop to ground passes through the internal shunt.

**Standard voltage output** (pin 12) is obtained by leading the current signal (pin 13) through an internal shunt resistor (pin 12). At current signals in the ranges 0...1 VDC, a 50 Ω shunt (JP1) is applied; in the ranges 0...10 VDC, a 500 Ω shunt (JP2) is applied.

##### Digital output(s):

Both NPN / PNP and relay outputs can be set up with delayed on and off. The action on the outputs can be inverted, and the hysteresis can be set acc. to your specifications. At power-up, shifts on the outputs can be delayed for up to 999 s.

**NPN and PNP outputs** for external relay, electromechanical counter, PLC input, or equivalent load.

The outputs are current-limited by way of PTC resistors.

Active output is established by connecting the NPN to the PNP output (jumper pins 22-23).

##### Relay outputs:

The PRecon 5225 can be delivered with 2 relay outputs that are programmed individually.

##### Status indication:

The 5225 is equipped with 4 front LEDs.

**f in:** Indicates an active input (non-active at NPN input).

**Dig. out. 1:** Indicates active NPN or relay 1 output.

**Dig. out. 2:** Indicates active relay 2 output.

**Error:** Indicates sensor error at NAMUR input.

## Electrical specifications:

### Specifications range:

-20°C to +60°C

### Common specifications:

Supply voltage.....	19.2...28.8 VDC
Internal consumption.....	1.7 W
Max. consumption.....	3.5 W
Power-up delay (digital outputs).....	0...999 s
Warm-up time.....	30 s
Communications interface .....	Loop Link
Signal / noise ratio.....	min. 60 dB
Response time, analogue.....	< 60 ms + period
Response time, digital output .....	< 50 ms + period
Response time, concurrent f/l and f/f.....	< 80 ms + period
Calibration temperature.....	20...28°C
Temperature coefficient.....	< ±0.01% of span / °C
Linearity error .....	< ±0.1% of span
Effect of supply voltage change.....	< 0.002% of span / %V

### Auxiliary voltages:

Namur supply .....	8.3 VDC ±0.5 VDC / 8 mA
S0 supply.....	17 VDC / 20 mA
NPN / PNP supply .....	17 VDC / 20 mA
Special supply (programmable).....	5...17 VDC / 20 mA

EMC immunity influence .....

< ±0.5%
---------

Max. wire size.....	1 x 2.5 mm <sup>2</sup> stranded wire
Screw terminal torque .....	0.5 Nm
Humidity .....	< 95% RH (non-cond.)
Dimensions (HxWxD).....	109 x 23.5 x 130 mm
DIN rail type.....	DIN 46277
Protection degree.....	IP20
Weight .....	190 g

### Input:

#### General:

Measurement range .....	0...20 kHz
Min. measurement range.....	0.001 Hz
Max. offset.....	90% of selected max. frequency
Low cut off.....	0.001 Hz
Min. pulse width (without filter) .....	25 µs
Min. period (without filter).....	50 µs
Max. frequency (without filter).....	20 kHz
Min. pulse width (with filter).....	10 ms
Min. period (with filter).....	20 ms
Max. frequency (with filter) .....	50 Hz
Programmable trig-level .....	0.025...6.5 V (nom.)
Trig-level LOW .....	> 50% of trig high -50 mV

### Namur input acc. to DIN 19234:

Trig-level LOW .....	≤ 1.2 mA
Trig-level HIGH .....	≥ 2.1 mA
Input impedance .....	1000 Ω

### Sensor error detection (only for Namur):

Breakage .....	≤ 0.1 mA
Short-circuit.....	≥ 7.0 mA
Response time .....	≤ 400 ms

### Tacho input:

Trig-level LOW .....	≤ -50 mV
Trig-level HIGH .....	≥ 50 mV
Input impedance .....	≥ 100 kΩ
Max. input voltage.....	80 VAC pp

### NPN / PNP input:

Trig-level LOW .....	≤ 4.0 V
Trig-level HIGH .....	≥ 7.0 V
Input impedance, standard .....	3.48 kΩ
Input impedance, special version.....	13.3 kΩ / NPN

### TTL input:

Trig-level LOW .....	≤ 0.8 VDC
Trig-level HIGH .....	≥ 2.0 VDC
Input impedance .....	≥ 100 kΩ

### S0 input acc. to DIN 43 864:

Trig-level LOW .....	≤ 2.2 mA
Trig-level HIGH .....	≥ 9.0 mA
Input impedance .....	800 Ω

### Analogue output:

#### Current output:

Signal range .....	0...20 mA
Min. signal range .....	5 mA
Max. offset.....	50% of select. max. value
Signal dynamics .....	16 bit
Updating time.....	20 ms
Updating time for concurrent f/l and f/f.....	40 ms
Load (max.).....	20 mA / 600 Ω / 12 VDC
Load stability .....	< ±0.01% of span / 100 Ω
Current limit .....	≤ 23 mA

### Voltage output through internal shunt:

Signal range .....	0...10 VDC
Min. signal span .....	250 mV
Max. offset.....	50% of select. max. value
Load (min.).....	500 kΩ

### Digital outputs (NPN / PNP):

I <sub>max</sub> . source .....	30 mA
I <sub>max</sub> . sink .....	130 mA
V <sub>max</sub> . .....	28.5 VDC

### f/f converter output:

Signal range .....	0...1000 Hz
Multiplicator / Divisor .....	1.0000...1000000
Min. pulse width .....	500 µs
Max. pulse width .....	999 ms
Max. duty cycle .....	50%

### Frequency generator:

Min. period .....	50 µs
Max. frequency.....	20 kHz
Duty cycle.....	50%

### Relay output:

Isolation, test / operation.....	3.75 kVAC / 250 VAC
Frequency max.....	20 Hz
V <sub>max</sub> . .....	250 VRMS
I <sub>max</sub> . .....	2 A / AC
Max. AC power.....	500 VA
Max. load at 24 VDC .....	1 A

### GOST R approval:

VNIIM, Cert. no. .... See homepage

### Observed authority requirements: Standard:

EMC 2004/108/EC .....	EN 61326-1
LVD 73/23/EEC.....	EN 61010-1
PELV/SELV.....	IEC 364-4-41 and EN 60742

**Of span =** Of the presently selected range

Options index 5225:

\*1: f/I converter

\*2: f/f converter

\*3: f/I and f/f converter

\*4: Frequency generator

**Digital input:**

\*1,3 Unit: Frequency / Period  
0% \_\_\_\_ Hz/s 100% \_\_\_\_ Hz/s

\*1,2,3 Input type: Tacho / TTL / NPN / PNP / S0 / NAMUR  
Special Current / Special Voltage  
Trig level high \_\_\_\_ mA/V Trig level low \_\_\_\_ mA/V Spec. sensor supply \_\_\_\_ V

\*1,2,3 Input filter:  
Disable / 50 Hz Lowpass

**Analogue output:**

\*1,3 Unit: Current / Voltage  
0...20 mA, 4...20 mA, 20...0 mA, 20...4 mA / 0...10 V, 0...1 V, 10...0 V, 1...0 V  
Fixed output \_\_\_\_ mA/V / Specify 0% \_\_\_\_ mA/V 100% \_\_\_\_ mA/V

\*1,3 Response time:  
\_\_\_\_ s

\*1,3 Sensor error (NAMUR):  
Off / Hold / Specify error value \_\_\_\_ mA

**Digital output 1:**

\*1 Output 1: Off / Activate for incr. freq. / Activate for decr. freq.  
Setpoint \_\_\_\_ Hz/s Hysteresis \_\_\_\_ Hz/s  
/Window  
High limit \_\_\_\_ Hz/s Low limit \_\_\_\_ Hz/s

\*4 Frequency:  
\_\_\_\_ Hz

\*1 Output 1 delay: Delay on / Delay off Power on delay  
\_\_\_\_ s / \_\_\_\_ s \_\_\_\_ s

\*1,2,3 Output 1 action:  
NPN or relay N.C. / PNP or relay N.O.

\*2,3 Output 1 function: Multiply: P1\*InA / Divide: InA/P1  
P1: \_\_\_\_\_ Pulse time \_\_\_\_ s

\*1,2,3 Sensor error action:  
Off / Close / Open / Hold

**Digital output 2:**

\*1,3 Output 2: Off / Activate for incr. freq. / Activate for decr. freq.)  
Setpoint \_\_\_\_ Hz/s Hysteresis \_\_\_\_ Hz/s

\*3 Output 2 window: /Window  
High limit \_\_\_\_ Hz/s Low limit \_\_\_\_ Hz/s

\*1,3 Output 2 action:  
NPN or relay N.C. / PNP or relay N.O.

\*1,3 Output 2 delay: Delay on / Delay off Power on delay  
\_\_\_\_ s / \_\_\_\_ s \_\_\_\_ s

\*1,2,3 Sensor error action:  
Off / Close / Open / Hold

\*1,2,3 Error LED:  
Disable / Sensor error (NAMUR)

Order: 5225

Type	Version	Output
5225	Standard : A	Analogue + NPN / PNP : 1 Analogue + Relay output : 2

**Block diagram:**

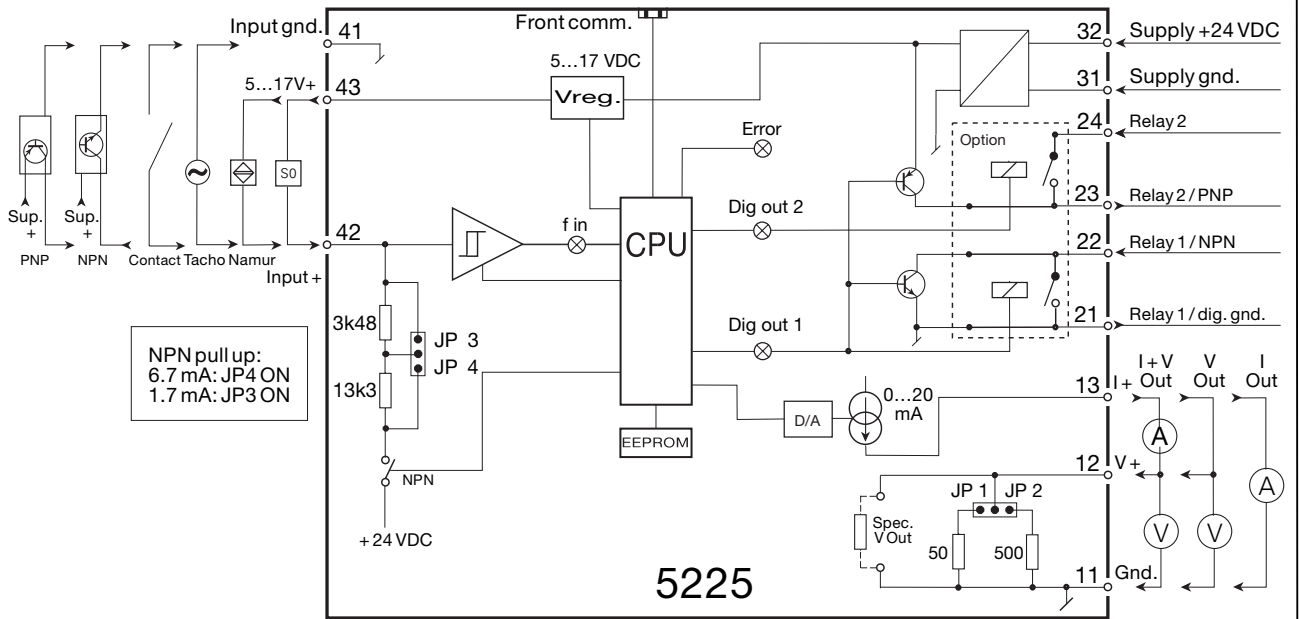

**Front layout:**

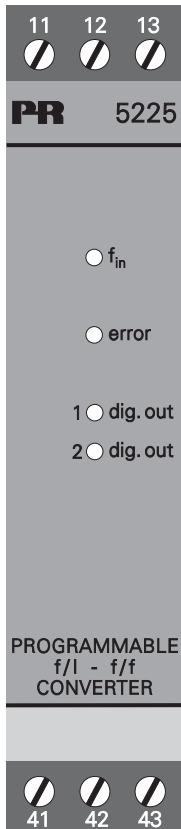

**5225 connection to Loop Link:**

