

2-WIRE TRANSMITTER-REPEATER



- Repeater for 2-wire transmitter 4...20 mA
- Loop-powered 10...35 VDC
- Galvanically isolated 3.75 kVAC
- 2-wire supply up to 15 VDC
- 1- and 2-channel versions
- For DIN rail mounting



Applications:

The PReTrans 5132 transmitter is ideal for galvanic isolation of 4...20 mA current signals from 2-wire transmitters.

Technical characteristics:

The voltages V_{supply} , $V_{transmitter}$ supply and V_{load} are floating. This means that a higher V_{supply} will cause a higher $V_{transmitter}$ supply. The listed voltages for transmitter supply are max. values.

Input / transmitter supply:

The transmitter supply is floating and dependent on V_{supply} , V_{load} (output) and V_{drop} isolator. The actual transmitter supply may be calculated by using this expression:

$$V_{transmitter\ supply} = V_{supply} - (V_{load} + V_{drop\ isolator}).$$

Output / supply:

The repeater output is supplied by the 2-wire connection from the external power supply or loop supply from the receiving equipment. The 4...20 mA signal, which is transferred from the transmitter, is repeated 1:1. By short-circuit of the input terminals the output current is limited to 40 mA. Max. output load is calculated after the following expression:

$$R_{load\ max} = \frac{V_{supply} - (V_{transmitter\ drop} + V_{drop\ isolator})}{0.02\ A}$$

Electrical specifications:

Specifications range:

-20°C to +60°C

Common specifications:

Supply voltage.....	10...35 VDC
Vdrop.....	< 4 VDC
Isolation, test / operation.....	3.75 kVAC / 250 VAC
Warm-up time.....	5 min.
Signal / noise ratio.....	> 60 dB (0...100 kHz)
Response time (0...90% / 100...10%)	≈ 2 ms
Calibration temperature.....	20...28°C
Temperature coefficient.....	< ±0.01% of span / °C
Linearity error.....	< ±0.1% of span
Effect of V_{supply} change.....	≤ 0.005% of span / V
AC effect of ripple on V_{supply}	≤ 0.5% AC of span/VAC (@ 100 Hz)
Transmitter supply (pin 43...41).....	> 15 VDC (24 V_{supply} - 5 V load)
EMC immunity influence.....	< ±0.5%
Wire size.....	1 x 2.5 mm ² stranded wire
Screw terminal torque.....	0.5 Nm
Relative air humidity.....	< 95% RH (non-cond.)
Dimensions (HxWxD).....	109 x 23.5 x 130 mm
DIN rail.....	DIN 46277
Protection degree (encl. / terminals) .	IP50 / IP20
Weight.....	250 g

Input:

Measurement range.....	4...20 mA
Min. measurement range (span).....	16 mA

Output:

Signal range.....	4...20 mA
Min. signal range (span).....	16 mA
Current limit.....	40 mA

GOST R approval:

VNIIM, Cert. no.....	Ross DK.ME48.V01899
----------------------	---------------------

Observed authority requirements: Standard:

EMC 2004/108/EC	Emission and immunity.....	EN 61326
LVD 2006/95/EC.....		EN 61010-1
PELV/SELV.....		IEC 364-4-41 and EN 60742

Of span = Of the presently selected range

Order: 5132

Type	Version	Channels
5132	Standard : A	1 channel : 1 2 channels : 2

Block diagram:

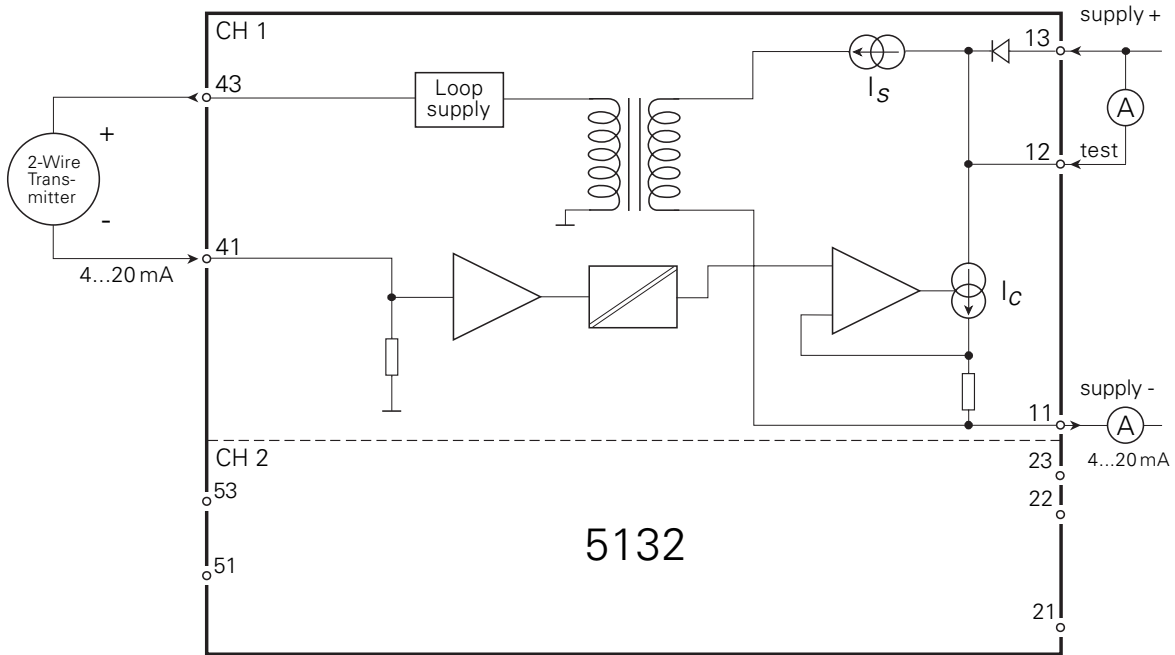

Front layout:



Application:

