

RTD TRANSMITTER



- Programmable via PC
- Input for Pt100, Ni100 or Ohm
- Linearised analogue output
- 24 VDC supply
- 1- or 2-channel version
- DIN rail mounting



Application:

Linearised temperature measurement with Pt100 or Ni100 sensor. ● Conversion of linear resistance change to standard analogue current / voltage signal from e.g. valves or linear movements with attached potentiometer. ● Signal simulator via externally mounted 10-turn potentiometer.

Technical characteristics:

General:

The transmitter may be configured to the requested signal type by means of a DOS-based PC with the configuration program PReset 5000 and the communications unit Loop Link. The configuration of the transmitter may be done without connection of supply voltage as the communications unit supplies the required power. The supply voltage is 24 VDC with the same reference point for supply, input and output ground. The sensor connection is always a 3-wire connection with cable compensation for up to 50 Ω in each wire. If a 2-wire connection is requested, pins 43 and 42 (channel 1) or 53 and 52 (channel 2) must be short-circuited in the connection plug (no cable compensation). Sensor error detection is as standard set to Upscale, Downscale or entered to special output value.

Input:

Linearised Pt100 temperature input according to IEC 751 within the range -200...+850°C. Linearised Ni100 temperature input according to DIN 43760 within the range -50...+250°C. Linear resistance input within the range 0...10 k Ω . Min. span for the RTD input is 50°C, for linear resistance 30 Ω . The RTD input can be delivered set up in multiples of the main type (e.g. Pt1000). The input can be reversed so that 0% e.g. is 150°C and 100% is 0°C.

Output:

The analogue output may be configured to any current within the range 0...20 mA or voltage within the range 0...10 VDC with a min. span of 5 mA or 250 mVDC with a max. offset of 50% of the actual max. value. Voltage signals are produced by short-circuiting pins 13 and 12 (channel 1) or 23 and 22 (channel 2) together with mounting a jumper for internal shunt resistance. For voltage signals within the range 0...1 VDC a 50 Ω shunt (JP1) is used, within the range 0...10 VDC a 500 Ω shunt (JP2) is used. The voltage signal is available between pins 12 and 11 (channel 1), or 22 and 21 (channel 2). The min. load resistance for voltage signals is 500 k Ω .

Electrical specifications:

Specifications range:

-20°C to +60°C

Common specifications:

Supply voltage.....	19.2...28.8 VDC
Internal consumption.....	1.7 W (2 channels)
Warm-up time.....	< 5 min.
Communications interface	Loop Link
Signal / noise ratio.....	Min. 60 dB
Signal dynamics, input	17 bit
Signal dynamics, output.....	16 bit
Response time (0...90%, 100...10%)..	< 165 ms
Calibration temperature.....	20...28°C
Temperature coefficient	< $\pm 0.01\%$ /°C _{amb} .
Linearity error	< 0.1% of span
EMC immunity influence	< $\pm 0.5\%$ of span
Screw terminal torsion.....	0.5 Nm
Humidity	< 95% RH (non-cond.)
Dimensions (HxWxD).....	109 x 23.5 x 130 mm
DIN rail type.....	DIN 46277
Protection degree.....	IP20
Weight	170 g

Input:

Type	Min. value	Max. value	Min. span	Standard
Pt100	-200°C	+850°C	50°C	IEC 751
Ni100	-50°C	+250°C	50°C	DIN 43760
Lin.R	0 Ω	10 k Ω	30 Ω	-----

Max. offset.....	50% of selected max. value
Cable resistance per wire (prog.).....	Max. 10...50 Ω
Sensor current	> 0.2, < 0.4 mA
Basic accuracy	< $\pm 0.3^\circ\text{C}$
Temp. coefficient for span <100°C....	< $\pm 0.01^\circ\text{C}/^\circ\text{C}_{\text{amb}}$.
Sensor error detection.....	Upscale/Downscale/selec. value

Output:

Signal range	0...20 mA / 0...10 VDC
Min. signal range	5 mA / 250 mV
Max. offset.....	50% of selected max. value
Load (max.).....	20 mA / 600 Ω / 12 VDC
Load stability	< 0.01% of span / 100 Ω
Current limit.....	< 28 mA

GOST R approval:

VNIIM, Cert. no. See www.prelectronics.com

Observed authority requirements: Standard:

EMC 2004/108/EC EN 61326-1

Of span = Of the presently selected range

Order: 5102

Type	Channels
5102	1 channel : A
	2 channels : B

Block diagram:

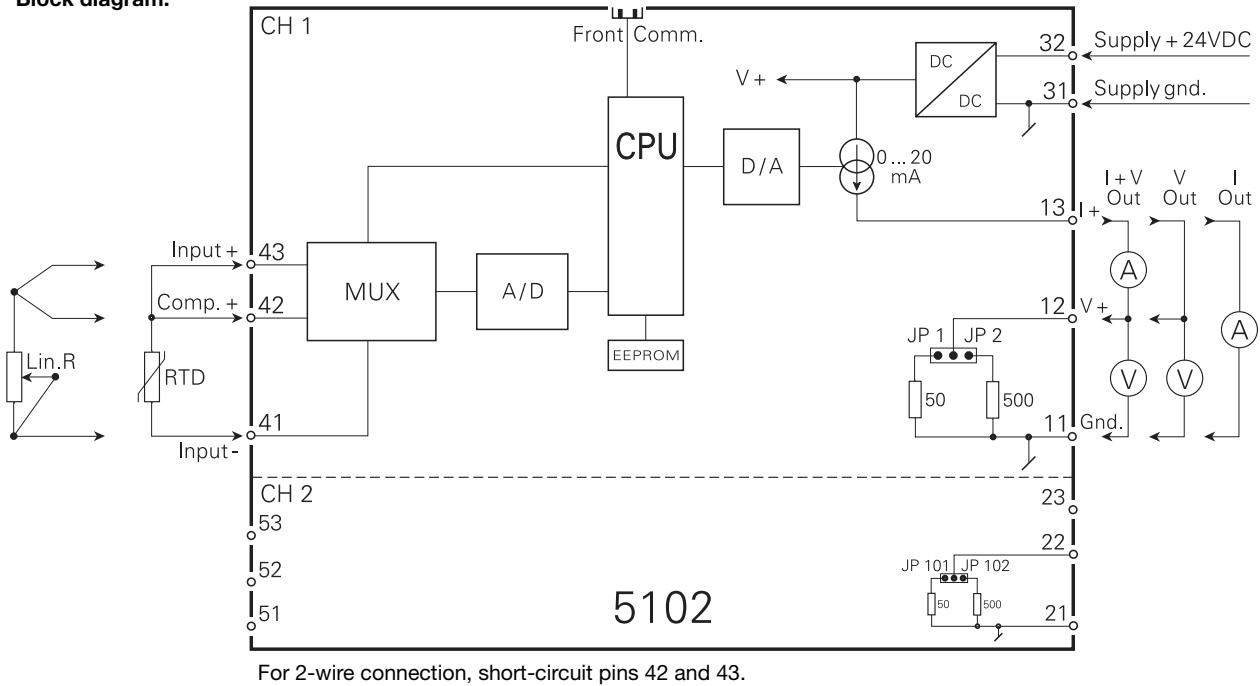

Front layout:



5102 connection to Loop Link:

