

SIGNAL CONTROLLER



- Multiple functions
- Programmable from front
- 3-digit LED display
- Analogue or Pt100 input
- Relay outputs
- Max. 50% offset



Applications:

PID on/off controller, PI step controller or 3-band controller with analogue or Pt100 input. ● As trip amplifier with setpoint adjustment through external current / voltage signal with neutral zone surrounding the setpoint. ● Especially suitable in applications where easy 11-pole relay socket mounting is required for instance in a panel. ● Possibility of readout of process data through the built-in display.

Technical characteristics:

General:

The 2286 is microprocessor-controlled and basic-calibrated. This means that the input and output can be programmed acc. to the requested signal range without any re-adjustment. Thereby a high degree of accuracy and flexibility are ensured. The output consists of two relays with a make contact connected to a common point. The user interface consists of a 3-digit display and 3 function keys in the front. The interface is used to change a function or an input signal range.

Inputs:

Analogue inputs - 2286A

The A and B channels can be freely programmed via the front keys and JP1 and JP2 to current in the range 0...20 mA or voltage in the range 0...10 VDC with a max. offset of 50% of the present max. value.

Pt100 input - 2286B

Linearised Pt100 temperature input in the range -99...+850 °C with 3-wire connection. The temperature range can be scaled via the front keys. Max. offset is 50% of max. temperature, min. span is 50°C.

Functions:

PID on/off controller:

Accurate setting of the regulation parameters XP (proportional band), TI (integrating time) and TD (differentiating time), with the units selected as XP %, TI s and TD s. Minimum XP is 0.01% equivalent to a gain of 10,000. By setting TI and TD to 0, the function will be a pure proportional controller. The controller adjusts the time interval between the pulses on the output, the pulse width is set by the parameter TP. When the process value is outside the proportional band, the output gives a constant up/down signal until the process value is brought within the proportional band. Hereafter the output pulses with a variable interval depending on the distance from the setpoint. The neutral zone is an accepted deviation in relation to an ideal output value, where no function is required on the output. The neutral zone is set in %. The setpoint can be selected as internal (external setpoint input disabled) or as external (current / voltage).

PI step controller:

The PI step controller is especially suitable for control of motor-driven valves, throttle valves and dosage units. When the process value is outside the proportional band, the output will give a constant up / down signal until the process value is brought within the proportional band. Hereafter the output pulses with a variable OFF time depending on the distance from the setpoint. A selected minimum ON time protects the motor against too short activations. The regulation parameters are XP (proportional band), tAU (exponential average time of the active relay state) - functions as integrating time, tP (the shortest active time of the relays) and nEU (neutral zone) - the band that the process is to be kept within. The setpoint can be selected as internal (external setpoint input disabled) or as external (current / voltage).

3-band controller:

The neutral zone is an accepted deviation in relation to the setpoint where no function is required on the output. The neutral zone is set in % of the input span and centered around the setpoint. If the process input drops below the neutral zone, the "up"-relay is activated until the process input rises to the setpoint value. Similarly the "down"-relay is activated if the process input rises above the neutral zone, and releases when the input signal drops to the setpoint value. The setpoint can be selected as internal (external setpoint input disabled) or as external (current / voltage).

dl/dt function:

The function monitors the size of the decrease or increase (dl) of the input within a set period of time (dt). If the set ratio, i.e. change per time unit, is exceeded, the relays will be activated. A time constant can be selected for the averaging of the input value.

Comparator with an external setpoint:

The process value is compared to the external setpoint, and if the two signals differ, a relay will be activated, i.e. the UP relay for process values larger than the setpoint plus a 1/2 neutral zone, and the DOWN relay for values below the setpoint minus a 1/2 neutral zone.

Trip amplifier with an external setpoint:

The relay function can be selected for increasing / decreasing or window. As a trip amplifier the relays can be activated individually when the input value differs from the setpoint plus or minus the neutral zone. The window function activates a relay when the process value differs by more than the neutral zone from the setpoint. The two relays can be activated independently by a common setpoint.

Output:

2 relay outputs with a make contact connected to a common point. Relay outputs can be installed in PELV/SELV circuits.

Electrical specifications - type 2286:

Specifications range:

-20°C to +60°C

Common specifications:

Supply voltage.....	19.2...28.8 VDC
Internal consumption.....	2.5 W
Max. consumption.....	3 W
Isolation test / operation.....	3.75 kVAC / 250 VAC
Signal / noise ratio.....	Min. 60 dB
Signal dynamics, input.....	20 bit
Proportional band (XP).....	0.01...999 %
Gain, 1/XP =	0.1...10000 gg
Integrating time (TI).....	0...999 s
Differentiating time (TD).....	0...999 s
Neutral zone (nEU).....	0...99.9 %
Pulse time (TP).....	0.01...400 s
Min. pulse time (TP).....	0.01...10 s
Response time.....	< 60 ms
Calibration temperature.....	20...28°C
Temperature coefficient.....	< ± 0.01% of span/°C
Linearity error.....	< ± 0.1% of span
Effect of supply voltage change.....	< ± 0.002% of span/%V
Auxiliary voltages:	
Reference voltage.....	2.5 VDC ± 0.5% / 15 mA
EMC immunity influence.....	< ± 0.5%
Relative air humidity.....	< 95% RH (non-cond.)
Dimensions (HxWxD).....	84.5 x 35.5 x 80.5 mm (excl. pins)
Tightness.....	IP 50
Weight.....	140 g

Electrical specifications - INPUT:

Current input:

Measurement range.....	0...20 mA
Min. measurement range (span).....	4 mA
Max. offset.....	50% of selec. max. value
Input resistance.....	50 Ω

Voltage input:

Measurement range.....	0...10 VDC
Min. measurement range (span).....	200 mV
Max. offset.....	50% of selec. max. value
Input resistance.....	Nom. 10 MΩ

Pt100 input 2286B:

Measurement range.....	-99...+850°C
Min. measurement range (span).....	50°C
Max. offset.....	50% of selec. max. value
Cable resistance per wire (max.).....	25 Ω
Sensor current.....	Nom. 1.25 mA
Response time.....	< 100 ms
Basic accuracy.....	< ± 0.2°C
Temperature coefficient.....	
span < 100°C.....	± 0.01°C/°C _{amb.}
span > 100°C.....	± 0.01% of span/°C _{amb.}
Immunity influence.....	
span ≤ 100°C.....	1% of span
span ≥ 100°C.....	0.5% of span
Effect of sensor cable resistance.....	< 0.002 Ω/Ω

Electrical specifications - OUTPUT:

Relay outputs:

Max. voltage.....	250 VRMS
Max. current.....	2 A / AC
Max. AC power.....	500 VA
Max. load at 24 VDC.....	1 A

GOST R approval:

VNIIM.....	Cert. no. Ross DK.ME48.V01899
------------	----------------------------------

Observed authority requirements: Standard:

EMC 2004/108/EC	
Emission and immunity.....	EN 61326
LVD 73/23/EEC.....	EN 61010-1
PELV/SELV.....	IEC 364-4-41 and EN 60742

Of span = of the presently selected range

Routing diagram

If no buttons are pressed for a period of 20 minutes, display returns to stage 0.0.

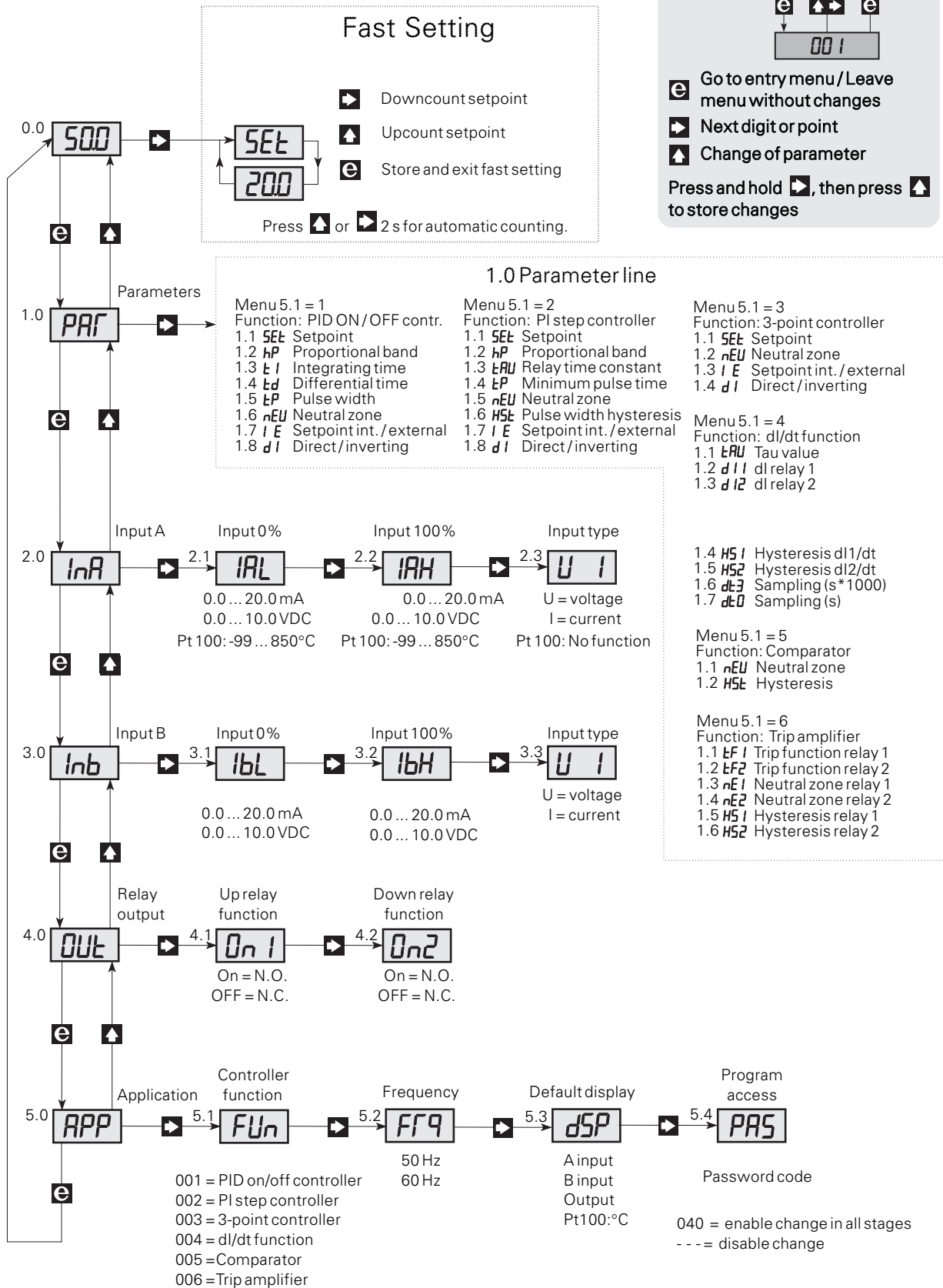

Order : 2286

Type	Input
2286	Voltage / current : A
	Temperature : B

Block diagram:

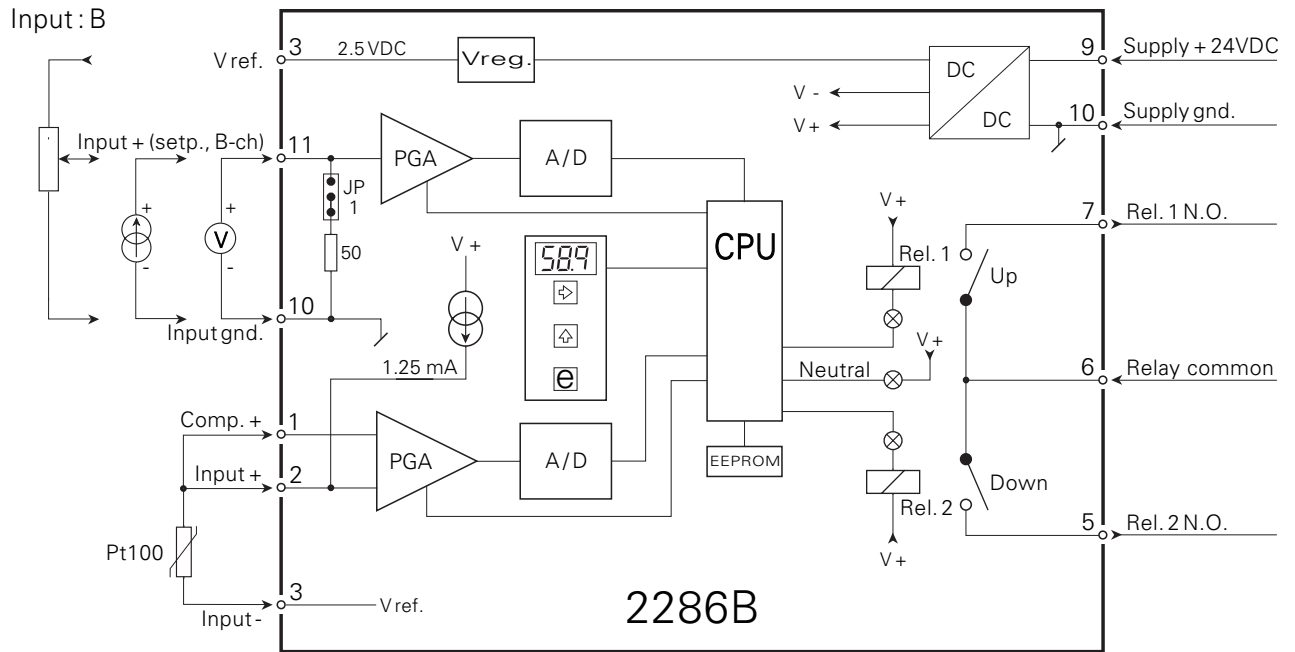
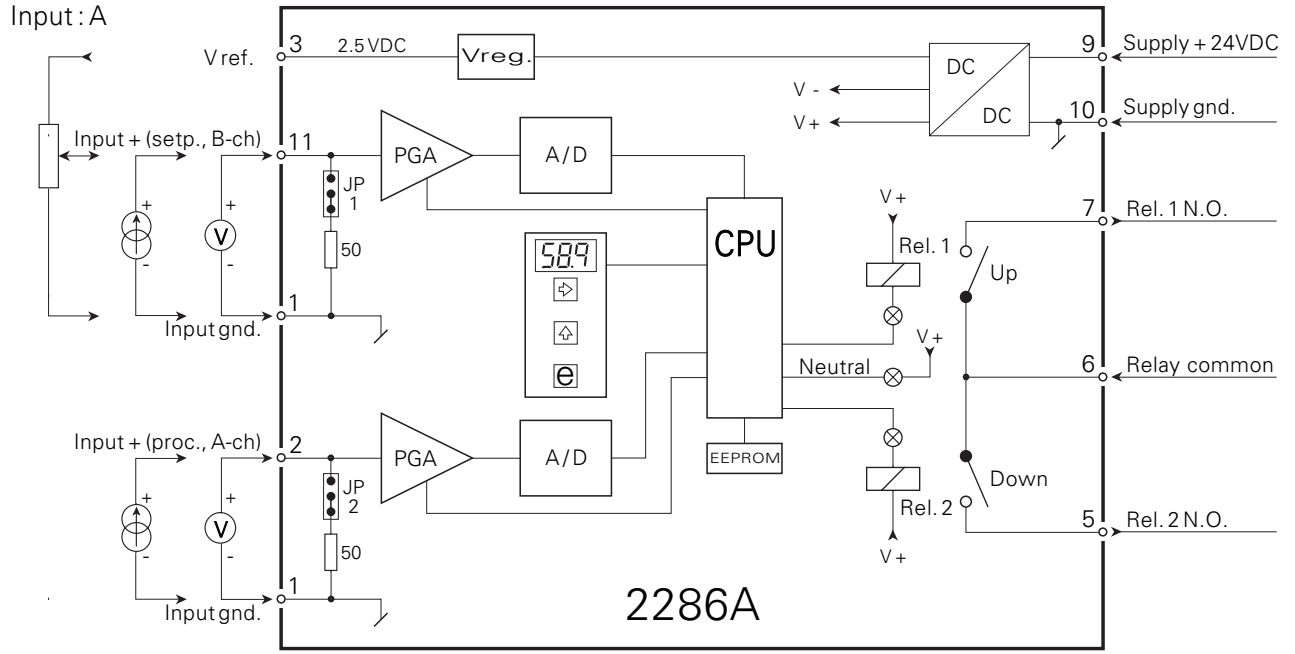

Hardware programming:

INPUT:

Channel A			
0...20 mA	JP2	ON	MENU 2.3 = I
0...10 VDC	JP2	OFF	MENU 2.3 = U
Channel B			
0...20 mA	JP1	ON	MENU 3.3 = I
0...10 VDC	JP1	OFF	MENU 3.3 = U