

DUAL TRIP AMPLIFIER



- 2 adjustable alarm levels
- 300 VA relay contacts
- Programmable input
- Programmable relay functions
- 24 VDC supply
- For mounting in 11-pole relay socket



Applications:

Alarm detector or controller in connection with DC current or voltage signals.

Technical characteristics:

Current or voltage as standard signals.
 Programmable via internal DIP-switches.
 All signals are referred to supply ground.
 Standard input voltage: See table
 Input resistance: Typ. 10 M Ω
 Standard input current: See table
 Input resistance: Nom. 50 Ω .
 Special input signals according to order. (see common specifications).

Setpoint:

Potentiometers for alarm level adjustment are front panel mounted and covers the entire input range (scale 0...100%). The alarm detector has relay outputs with two uncommitted change-over contacts available. The relays may be programmed to activate on a decreasing or an increasing input signal.
 By increasing function the hysteresis is below the setpoint, by decreasing above.
 The programming options include a 'hold'-function where relay 2 latches when the upper alarm level is reached. The latch is released by relay 1 when the lower alarm level is reached. Furthermore, a 'failsafe'-function may be selected, where the relays are deactivated on decreasing relay function, when the input signal is < 2% of the measurement range. LEDs in the cassette front plate indicate activated relays.

Electrical specifications:

Specifications range:

-20°C to +60°C

Common specifications:

Supply voltage.....	19.2...28.8 VDC
Internal consumption.....	1.2 W (relays ON)
Isolation test / operation.....	1.4 kVAC / 150 VAC
Scale accuracy	Better than 5%
Repetition accuracy	Better than 0.5%
Hysteresis.....	1% standard
Response time	Typ. 80 ms
Temperature coefficient.....	< $\pm 0.01\%$ of span / °C
EMC immunity influence	< 1%
Relative humidity	< 95% RH (non-cond.)
Dimensions (HxWxD).....	80.5 x 35.5 x 84.5 mm
Tightness.....	IP50
Weight	125 g

Input:

Max. measurement range.....	50 mA / 24 VDC
Min. measurement range (span).....	0.8 mA / 800 mVDC
Max. offset.....	20% of selected max. value
Input resistance, current.....	50 Ω
Input resistance, voltage	Nom. 10 M Ω

Output:

Relay output:	
Max. voltage.....	150 VRMS
Max. current	2 A / AC
Max. AC power.....	300 VA
Max. load at 24 VDC	1 A

GOST R approval:

VNIIM..... Cert. no. Ross DK.ME48.V01899

Observed authority requirements: Standard:

EMC 2004/108/EC	
Emission and immunity	EN 61326
LVD 73/23/EEC.....	EN 61010-1

Of span = Of the presently selected range

Order: 2238

Type	Input	Output	Setpoint
2238	0...20 mA : A	2 x active at increasing input : 1	Setp. notch opr. : A
	4...20 mA : B	2 x active at decreasing input : 2	Setp. knob opr. : B
	0...1 V : C	Active at decreasing input 1 + at increasing input 2 : 3	
	0.2...1 V : D	Active at decreasing input 2 + at increasing input 1 : 4	
	0...10 V : E	Hold rel. 2 : 5	
	Spec. : X		

Block diagram:

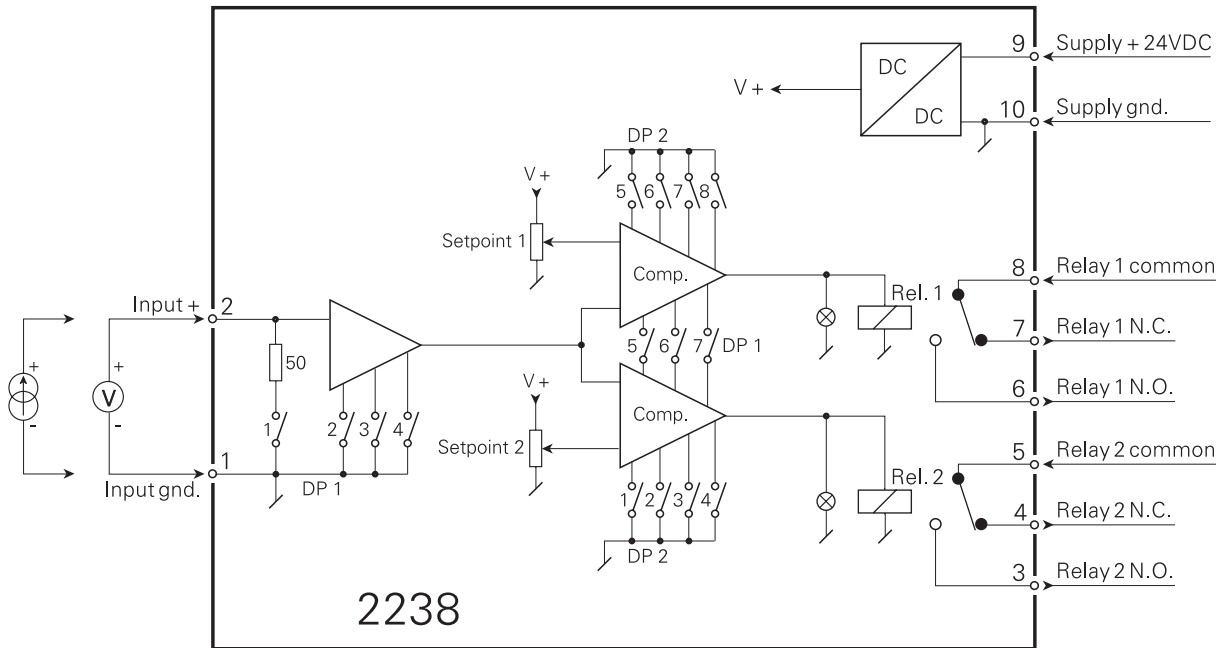

Front layout:

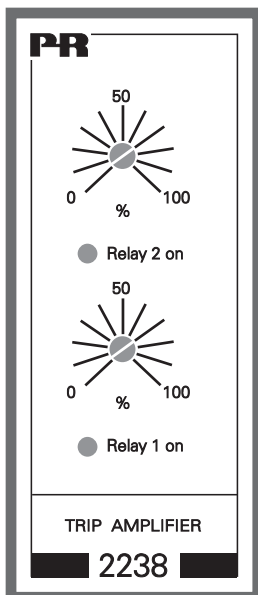

Programming:

Input and function	DP1 ON	DP2 ON
0...20 mA	1, 2	
4...20 mA	1, 3	
0...1 V	2	
0.2...1 V	3	
0...10 V	2, 4	
2...10 V	3, 4	
Active relay 1 at:		
Increasing input signal		5, 7
Decreasing input signal		6, 8
Active relay 2 at:		
Increasing input signal		1, 3
Decreasing input signal		2, 4
Relay 2 hold	5	
Relay 1 failsafe	7	
Relay 2 failsafe	6	

For safe operation, all other switches must be OFF.