

TRIP AMPLIFIER



- Adjustable alarm level
- 300 VA relay contacts
- Programmable input
- Programmable relay function
- 24 VDC supply
- For mounting in 11-pole relay socket



Applications:

Alarm detector or controller in connection with DC current or voltage signals.

Technical characteristics:

Current or voltage as standard signals, programmable via internal DIP-switches.

All signals refer to supply ground.

Standard input voltage: See table.

Input resistance: Typ. 10 M Ω .

Standard input current: See table.

Input resistance: Nom. 50 Ω .

Special input signals according to order (see common specifications).

Setpoint:

Potentiometer for alarm setpoint adjustment is front panel mounted and covers the entire measurement range (scale 0...100%).

The relay can be programmed to activate for increasing or decreasing input signal. By increasing function the hysteresis is below the setpoint, by decreasing above.

A LED in the cassette front plate indicates an activated relay.

Electrical specifications:

Specifications range:

-20°C to +60°C

Common specifications:

Supply voltage.....	19.2...28.8 VDC
Internal consumption.....	0.75 W (relay ON)
Isolation, test / operation.....	1.4 kVAC / 150 VAC
Scale accuracy	Better than 5%
Repetition accuracy	Better than 0.5%
Hysteresis.....	1% standard
Response time	Typ. 80 ms
Temperature coefficient.....	< $\pm 0.01\%$ of span / °C
EMC immunity influence	< 1%
Relative humidity	< 95% RH (non-cond.)
Dimensions (HxWxD).....	80.5 x 35.5 x 84.5 mm
Tightness.....	IP50
Weight	110 g

Input:

Max. measurement range.....	50 mA / 24 VDC
Min. measurement range (span).....	0.8 mA / 800 mVDC
Max. offset.....	20% of selected max. value
Input resistance, current.....	50 Ω
Input resistance, voltage	Nom. 10 M Ω

Output:

Relay output:	
Max. voltage.....	150 VRMS
Max. current	2 A / AC
Max. AC power.....	300 VA
Max. load at 24 VDC	1 A

GOST R approval:

VNIIM..... Cert. no. Ross DK.ME48.V01899

Observed authority requirements: Standard:

EMC 2004/108/EC	
Emission and immunity	EN 61326
LVD 73/23/EEC.....	EN 61010-1

Of span = Of the presently selected range

Order : 2237

Type	Input	Output	Setpoint
2237	0...20 mA : A	Active at increasing input : 1	Setp. notch opr. : A
	4...20 mA : B		
	0...1 V : C	Active at decreasing input : 2	Setp. knob opr. : B
	0.2...1 V : D		
	0...10 V : E		
	Spec. : X		

Block diagram:

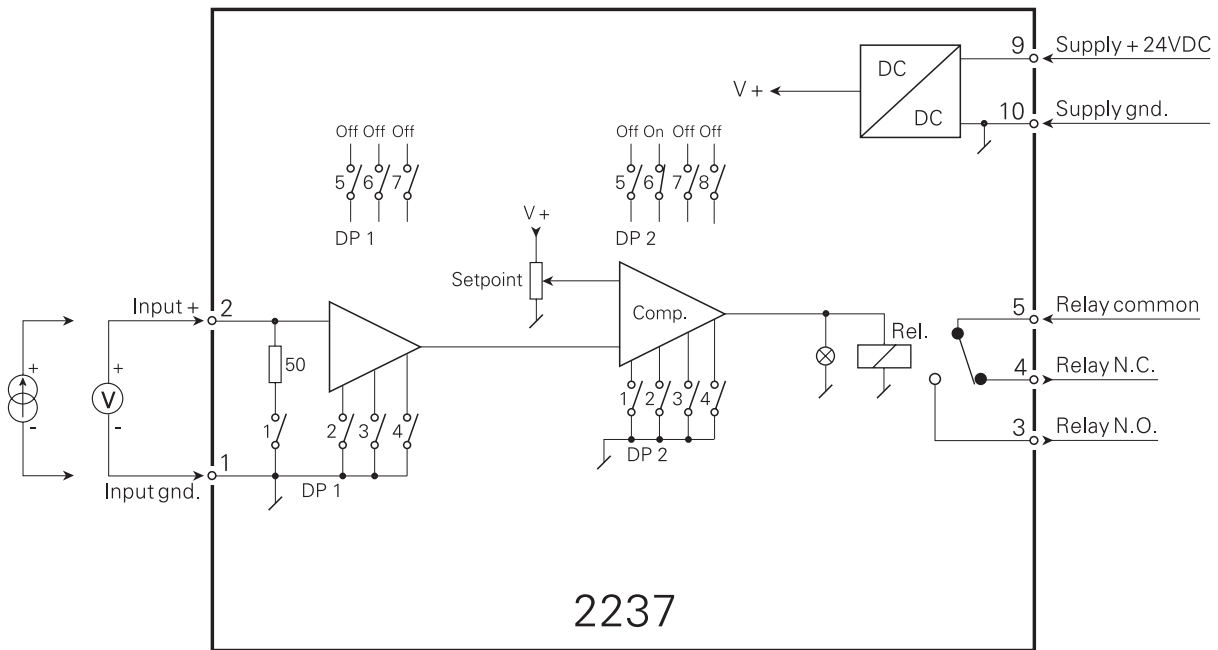

2237

Front layout:

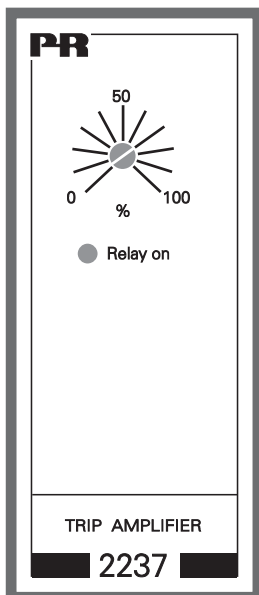

Programming:

Input and function	DP1 ON	DP2 ON
0...20 mA	1, 2	6
4...20 mA	1, 3	6
0...1 V	2	6
0.2...1 V	3	6
0...10 V	2, 4	6
2...10 V	3, 4	6
Active relay at:		
Increasing input signal		1, 3
Decreasing input signal		2, 4

For safe operation, all other switches must be OFF.