

DUAL SWITCHMODE POWER SUPPLY



- 24 / 115 / 230 VAC supply voltage
- 3.75 kVAC isolation
- 2 adjustable 5...24 VDC outputs
- Output: ± 5 ...24 VDC, 10...48 VDC
- Short-circuit protection
- Thermal protection against overload



Applications:

Supply for small measuring systems that demand 2 stabilised voltages. ● Either as a combination of positive and negative voltages, or as 2 separate supplies as required.

Technical characteristics:

To achieve an adjustable output with minimum power loss, the 2223 is based on switchmode technology. The isolation test voltage between input and outputs being 3.75 kVAC, the unit is suitable in PELV/SELV circuits. The double-isolated safety transformer has a bimetal fuse that disconnects the input circuit if the internal temperature exceeds 100°C. The fuse automatically resets.

Mounting:

The 2223 is for standard 11-pole socket mounting in all positions. To achieve maximum cooling of the module, mounting in a vertical position at a distance of minimum 10 mm between neighbouring units is recommended.

Input:

Standard supply voltage according to the specifications. The built-in double-isolated safety transformer ensures galvanic isolation.

Output:

The outputs are adjustable by 2 front potentiometers in the ranges 5...24 VDC. Two green LEDs, Power ON 1 and Power ON 2, indicate active outputs. The short-circuit protection limits the current on each output. The two supplies are galvanically separated with 500 VAC test voltage and can be connected in series or used as two independent supplies with or without common gnd. By connecting the two outputs in series, 10...48 VDC or ± 5 ...24 VDC are achieved. The total output power must not exceed 7.5 W.

As regards possible connections of the two outputs, please see the reverse.

Electrical specifications:

Specifications range:

-20°C to +60°C

Common specifications:

Internal consumption max.....	4 W
Isolation, test / operation.....	3.75 kVAC / 250 VAC
Isolation output 1 / 2, test / operation ..	500 VAC / 50 VAC (75 VDC)
Transformer	EN 60742
Temperature coefficient	0.05%/°C
Effect of supply voltage change ($\pm 10\%$)	< ± 30 mV
Transient stability (10%-max. load) ...	< 250 mV
EMC immunity influence	< $\pm 0.5\%$
Relative air humidity	< 95% RH (non-cond.)
Dimensions (HxWxD).....	80.5 x 35.5 x 84.5 mm
Tightness	IP30
Weight	400 g

Input:

Supply voltage.....	21.6...26.4 VAC
	103.5...126.5 VAC
	207...253 VAC
Frequency.....	50...60 Hz

Output:

Output voltage.....	4.75...25.2 VDC
Output power, total.....	Max. 7.5 W
Output current, per channel	0.5 A / 5 VDC (2.5 W)
	0.37 A / 12 VDC (4.5 W)
	0.30 A / 15 VDC (4.5 W)
	0.18 A / 24 VDC (4.3 W)
Load effect, (10%-max. load).....	< 1.5% / A
Current limit (short circuit)	Typ. 100 mA
Output ripple	< 20 mVRMS

GOST R approval:

VNIIM..... Cert. no. Ross DK.ME48.V01899

Observed authority requirements: Standard:

EMC 2004/108/EC	
Emission and immunity	EN 61326
LVD 73/23/EEC.....	EN 61010-1
PELV/SELV.....	IEC 364-4-41 and EN 60742

Order: 2223

Type	Version	Output 1	Output 2
2223	115 VAC : A	Special (5...24 VDC) : 0	Special (5...24 VDC) : 0
	230 VAC : B	24 VDC : 1	24 VDC : 1
	24 VAC : D	15 VDC : 2	15 VDC : 2
		12 VDC : 3	12 VDC : 3
		5 VDC : 4	5 VDC : 4

Block diagram:

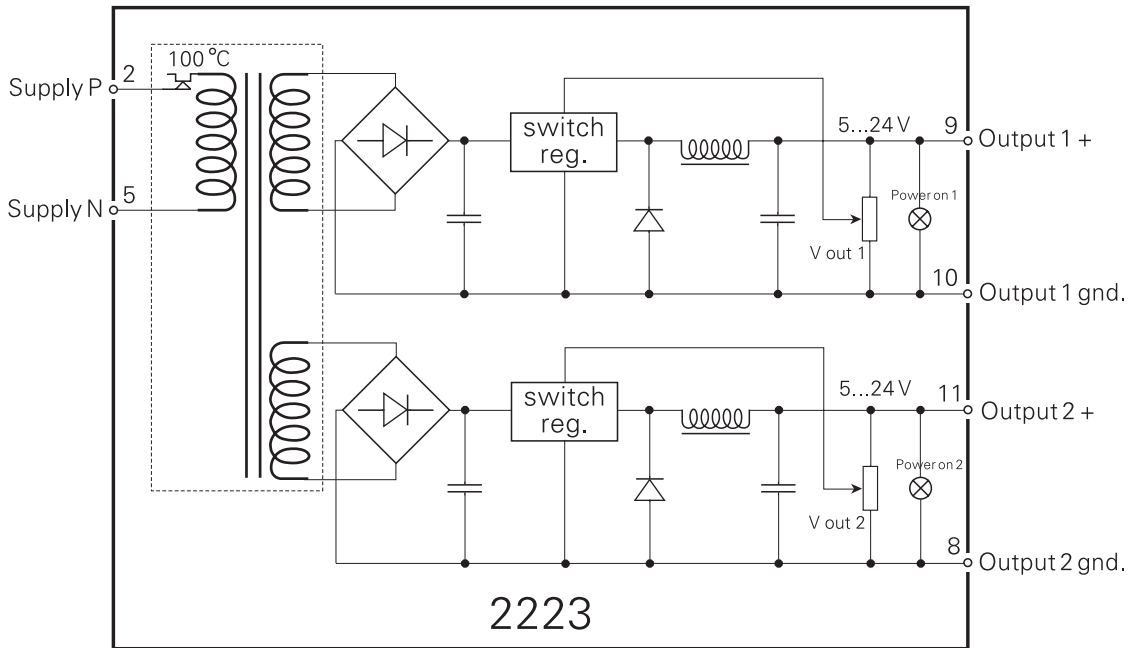

Front layout::

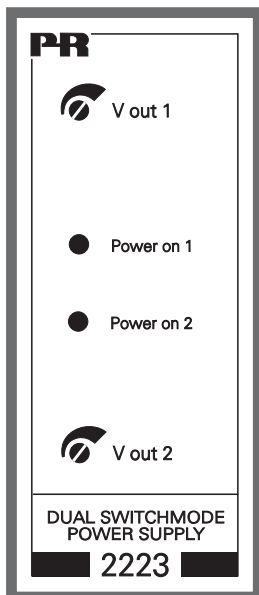

Connection diagram:

